

**flexium<sup>pro</sup>**

**CNC SYSTEM 2025/2026**

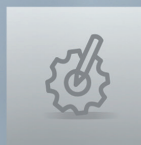

[www.num.com](http://www.num.com)

**NUM** <sup>®</sup>  
CNC HighEnd Applications







Introduction	1
FlexiumPro CNC System	2
Operator Panels and Industrial PC	3
FlexiumPro RTK	4
NUMSafe PLC and Safe I/Os	5
NUM Motors	6
Motor / Drive Associations	7
NUM DrivePro	8
NUM EtherCAT Terminals	9
Cables / Accessories	10
FlexiumPro Configurations	11
General Information	12



<b>Introduction</b>	<b>9</b>
NUM, a World Player in Machine Automation	9
FlexiumPro System	10
<b>FlexiumPro CNC System</b>	<b>13</b>
FlexiumPro System Overview	13
User / Customer Benefits	14
General Characteristics	16
Components	17
FlexiumPro and Safety	26
System Functions	27
General System Composition	27
CNC Functions	30
FlexiumPro HMI Functions	54
Flexium 3D	56
FlexiumPro Tools	59
FlexiumPro PLC Functions	63
NUMSafe	65
NUMSafe PLC Functions	66
NUM DrivePro Functions	69
Standard Functions	69
Optional Functions	70
Standard and Optional Safety Functions	71
FlexiumPro Options Grid Summary Table	73
FlexiumPro Main Component Summary	73
Basic Features and Optional Extensions	74
Machine Configuration	75
Axes, Spindle and Machining Functions	76
CNC Programming, Tools and Operation	77
PLC Functions	78
HMI Functions/Flexium 3D	79
Option Packs	80
Option Pack Contents	81
NUM DrivePro Functions	83
<b>Operator Panels and Industrial PC</b>	<b>85</b>
FS184i and FS244i Operator Panels with Integrated iPC	85
Technical Characteristics	86
FS184i Outlines	87
FS244i Outlines	89
Ordering Codes	91
FS154i Operator Panels with Integrated iPC	92
Technical Characteristics	94
Outlines	95
Ordering Codes	96
FS244, FS184, FS153 and FS122 Operator Panels	97



FS184 and FS244 Operator Panels without Integrated iPC	98
Technical Characteristics	99
Outlines	100
Ordering Codes	104
FS153 Operator Panels	105
User Interface Options	105
Technical Characteristics	106
Outlines	107
Ordering Codes	108
FS122 Operator Panel	109
User Interface Options	109
Technical Characteristics	110
Outlines	111
Ordering Codes	112
Machine Panels	113
Overview	113
MP06 Machine Panel	114
Technical Characteristics	115
Outlines	116
Ordering Codes	117
MP07 Machine Panel	118
Technical Characteristics	119
Outlines	120
Ordering Codes	121
MP08 Machine Panel	122
Technical Characteristics	123
Outlines	124
Ordering Codes	125
Machine Panel Accessories	126
Industrial Box PC	128
Technical Characteristics	131
Outlines	132
Ordering Codes	134
HBA-X Portable Handwheel	135
Technical Characteristics	137
Outlines	138
Ordering Codes	139
<b>FlexiumPro RTK</b>	<b>140</b>
Description	140
General Characteristics	142
Dimensions and Ordering Code	143
<b>NUMSafe PLC and Safe I/Os</b>	<b>144</b>
CTMP6900 - NUMSafe PLC	144



Technical Characteristics	145
Outlines and Ordering Code	146
CTMS1904 - NUMSafe Digital Inputs Terminal	147
Technical Characteristics	148
Outlines and Ordering Code	149
CTMS2904 - NUMSafe Digital Outputs Terminal	150
Technical Characteristics	151
Outlines and Ordering Code	152
CTMS2912 - NUMSafe Digital Outputs Terminal	153
Technical Characteristics	154
Outlines and Ordering Code	155
CTMP1960-2600 - NUMSafe Compact Controller	156
Technical Characteristics	157
Outlines and Ordering Code	158
<b>NUM Motors</b>	<b>160</b>
Overview and Product Positioning	160
BHX & SHX Servomotors	163
Characteristics	163
BHX - Ordering Codes	164
SHX - Ordering Codes	165
BPX & SPX Servomotors	166
Characteristics	166
BPX - Ordering Codes	167
SPX - Ordering Codes	168
BHX & BPX Servomotors	169
Outlines	169
SHX & SPX Servomotors	171
Outlines	171
BPH Servomotors	172
General Characteristics	172
Technical Characteristics	173
Ordering Codes	174
BPG Servomotors	175
Characteristics	175
Ordering Codes	176
BPH & BPG Servomotors	177
Outlines	177
BHL Servomotors	178
Characteristics	178
Ordering Codes	179
Outlines	180
TMX Direct Drive Torque Motors	181
General Characteristics	181
Technical Characteristics	182





Ordering Codes	183
Outlines	184
AMS & IM Spindle Motors	185
General Characteristics	185
Technical Characteristics	186
AMS Ordering Codes	187
IM Ordering Codes	188
Outlines	189
Encoder Characteristics	191
Custom Motors	192
<b>Motor/Drive Associations</b>	<b>194</b>
Servomotors	194
Association of BHX & SHX Motors with NUM DrivePro	194
Association of BPX & SPX Motors with NUM DrivePro	195
Association of BPH Motors with NUM DrivePro	196
Association of BPG Motors with NUM DrivePro	198
Association of BHL Motors with NUM DrivePro	200
Association of TMX Motors with NUM DrivePro	201
Spindle Motors	202
General Description	202
Association of AMS and IM Spindle Motors with NUM DrivePro	203
<b>NUM DrivePro</b>	<b>206</b>
Description	206
Overview	207
General Characteristics	209
Power Supply Characteristics	210
Servo Drive Interoperability	212
Servo Drive Technical Characteristics	214
Servo Drive	217
Outlines Size 1	217
Outlines Size 2	218
Outlines Size 2 Quad - Axes	219
Outlines Size 3	220
Outlines Size 4	221
Outlines Size 6	222
Power Supply	223
Outlines Size 2	223
Outlines Size 4	224
Outlines Size 6	225
Auxiliary Power Supply	226
Outlines Size 1	226
Power Supply Ordering Code	227
Servo Drive Ordering Code	228



<b>NUM EtherCAT Terminals</b>	<b>230</b>
General Characteristics	230
Gateways and Terminals	232
Ordering Code and Example	233
Technical Data and System Structure	234
<b>Cables / Accessories</b>	<b>236</b>
Overview	236
System Cables	239
System Connectors	241
NUM DrivePro Connectors and Adapters	242
NUM DrivePro Kits	244
Miscellaneous	247
Overview Power Supply and Accessories	248
NUM DrivePro Line Filters	249
NUM DrivePro Line Chokes	253
NUM DrivePro Braking Resistor	257
Vibration Detector (VDR)	262
Auto-Transformer	263
Capacitor module	264
Motor Cables and Connectors	265
<b>FlexiumPro Configurations</b>	<b>283</b>
Standard Configuration FlexiumPro 6 and FlexiumPro 8 System	283
Multi-Panel Configuration of FlexiumPro	284
FlexiumPro Configuration for Office PC	285
<b>General Information</b>	<b>287</b>
Addresses / Contacts of all NUM Subsidiaries	287
Regulations	290



### CNC Power Engineering - Always on the move

**NUM supplies complete CNC solutions for the automation of production machines in special market segments and for customers with special requirements. The high flexibility of our systems, combined with the extensive application knowledge and expertise of our innovative engineering team, allow us to tailor solutions to exactly match the needs of our partners – machine manufacturers and other members of the machine industry.**

Mission Statement:

#### **NUM CNC solutions provide machine builders with a competitive advantage**

Ever since launching its first CNC system in 1961, NUM has continued to develop and is now an independent European company with growing international activities. With our own sales and support facilities in all key regions we are able to support our machine building customers globally. We also have an extensive network of trained and certified after-sales service partners, so end-users all around the world have fast and easy access to service for machines based on NUM systems. The Flexium CNC system is NUM's biggest success to date – in the few years since its launch it has been installed on a huge number of machines. Machine builders and end-users can feel very comfortable and secure that they are in good company when choosing NUM's Flexium platform. NUM has operated at the leading edge of technology for more than 50 years and has pioneered some major developments in the market. True to our history, with the FlexiumPro system we have again set new standards. Building on the proven concept of the Flexium system, we have added new functionality and further enhanced performance, including a new state-of-the-art security concept and programmable touch-sensitive operator panels.

Visit our website or follow us on our social media channels for the latest information on NUM CNC Applications:

 [num.com](http://num.com)

 [twitter.com/NUM\\_CNC](https://twitter.com/NUM_CNC)

 WeChat-ID: NUM\_CNC\_CN

 [facebook.com/NUM.CNC.Applications](https://facebook.com/NUM.CNC.Applications)

 [linkedin.com/company/num-ag](https://linkedin.com/company/num-ag)

 [page.line.me/num\\_cnc](https://page.line.me/num_cnc)

#### **Accompaniment and support during the entire product lifecycle**

When you select a system and a solution from NUM, you are making a long-term investment. As your partner, we participate throughout the entire process: from the conception of the idea to its execution, from on-site customer service to retrofitting years later, giving new life to quality used machines.

NUM supports you and your projects to achieve the best results for your company and its customers. The goal of our cooperation is always the same: to help you create the best-possible solution for your project.

All of our solutions are based on perfectly integrated products such as CNC systems, servo drives and motors from our own extensive range. Partnership with our customers is maintained throughout the evaluation, project and installation phases by means of training courses, support and service centres, and continues after commissioning. We make a point of advising our customers with specific know-how from our experts.

When you choose NUM, you are also choosing customer service which will continue to serve you just like new long after you have made your initial investment – even after 20 years, we still serve on-site. Our specialists can extend the life of your quality older machines with NUM Retrofits.

NUM is committed to transferring its knowledge on a regular basis. CNC knowledge and special production expertise, as well as drive and application techniques, are the subjects of the training programs taught by our specialists.

# Introduction

## FlexiumPro System



### A Compact Scalable CNC System

FlexiumPro CNC is a key element of the solutions and systems of NUM.

The FlexiumPro system is easily scalable and can be fully adapted to the needs of customers. Available in three configurations FlexiumPro 6, FlexiumPro 8 and FlexiumPro 68, each equipped with specific functions and function packages, it can be tailored to the particular application.

To create an optimal CNC, just pick the platform best suited to the application and the machine, and include the appropriate options, either individually or as technology packages (turning, milling, woodworking, etc.).

#### FlexiumPro 6

- CNC with choice of kinematic structure: milling or turning
- CNC for up to 4 axes and 1 spindle
- One CNC channel
- Interpolates up to 4 axes simultaneously

*flexium*<sup>pro</sup> 6

#### FlexiumPro 8

- CNC for up to 5 axes or 4 axes and 1 spindle.
- One channel is standard, a second is optionally available
- Interpolates up to 4 axes simultaneously
- Various options and technology packages available

*flexium*<sup>pro</sup> 8

#### FlexiumPro 68

- CNC for 5 axes + spindles in standard version, up to 32 axes/spindles as an option
- One channel is standard. 2, 4, 6 or up to 32 channels as an option
- Interpolates 4 axes par channel as standard, up to 9 interpolated axes per channel as an option
- Various technology packages and interpolation functions are available as options

*flexium*<sup>pro</sup> 68

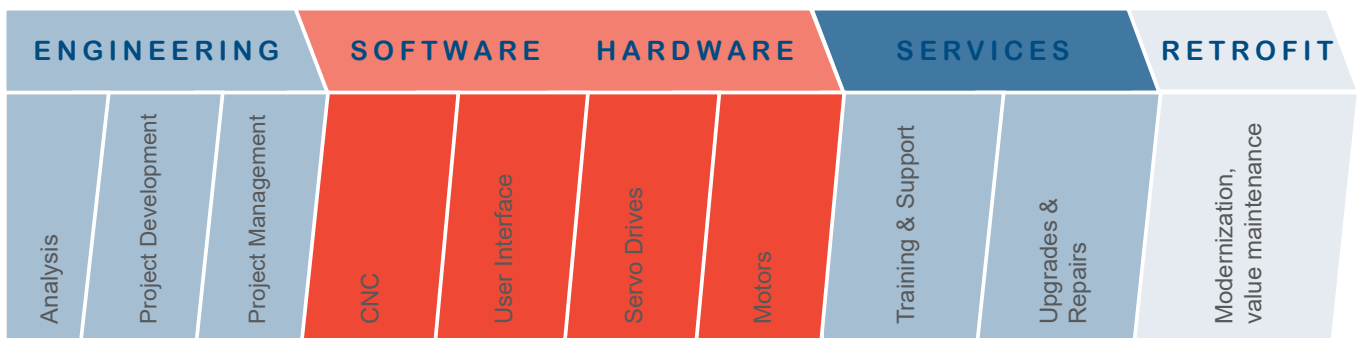





### Industry 4.0 ready

1

Industry 4.0 will fundamentally change the manufacturing world as we know it today. “IIoT” (Industrial Internet of Things) and “Smart Factory” are terms that are often used in connection with Industry 4.0. The precise beginning and end of this digital transformation cannot easily be determined. The changes are coming successively, have already begun, and/or are based on already implemented solutions. Over time, the entire production logic will change: in the future, intelligent machines, storage systems, operating resources, etc., will be organized independently in real-time-capable systems along the entire value-added chain. The ultimate goal is the Smart Factory. This is characterized by flexibility, resource efficiency and ergonomic design. The integration of customers’ and business partners’ value-added processes is also part of this. Control technology plays a major role in the success of Industry 4.0. It will ultimately control the machines that produce the real products. Anticipated benefits include improved effectiveness, innovation leaps, increased information transparency and competitive advantages.

NUM’s CNC controllers have always distinguished themselves through their openness and their versatile communication possibilities. These points have been continuously enhanced from one generation of controllers to the next. The FlexiumPro CNC control system includes a wide range of communication options, thus satisfying the basic prerequisite for a possible Smart Factory. Field buses such as EtherCAT or CAN are mostly used for horizontal integration. Vertical communication to SCADA, MES and ERP systems can be carried out via OPC, MTConnect and MQTT as well as other freely definable communication interfaces which can be implemented efficiently and comprehensively using NUM’s FXProServer and FlexiumPro HMI Adapter.

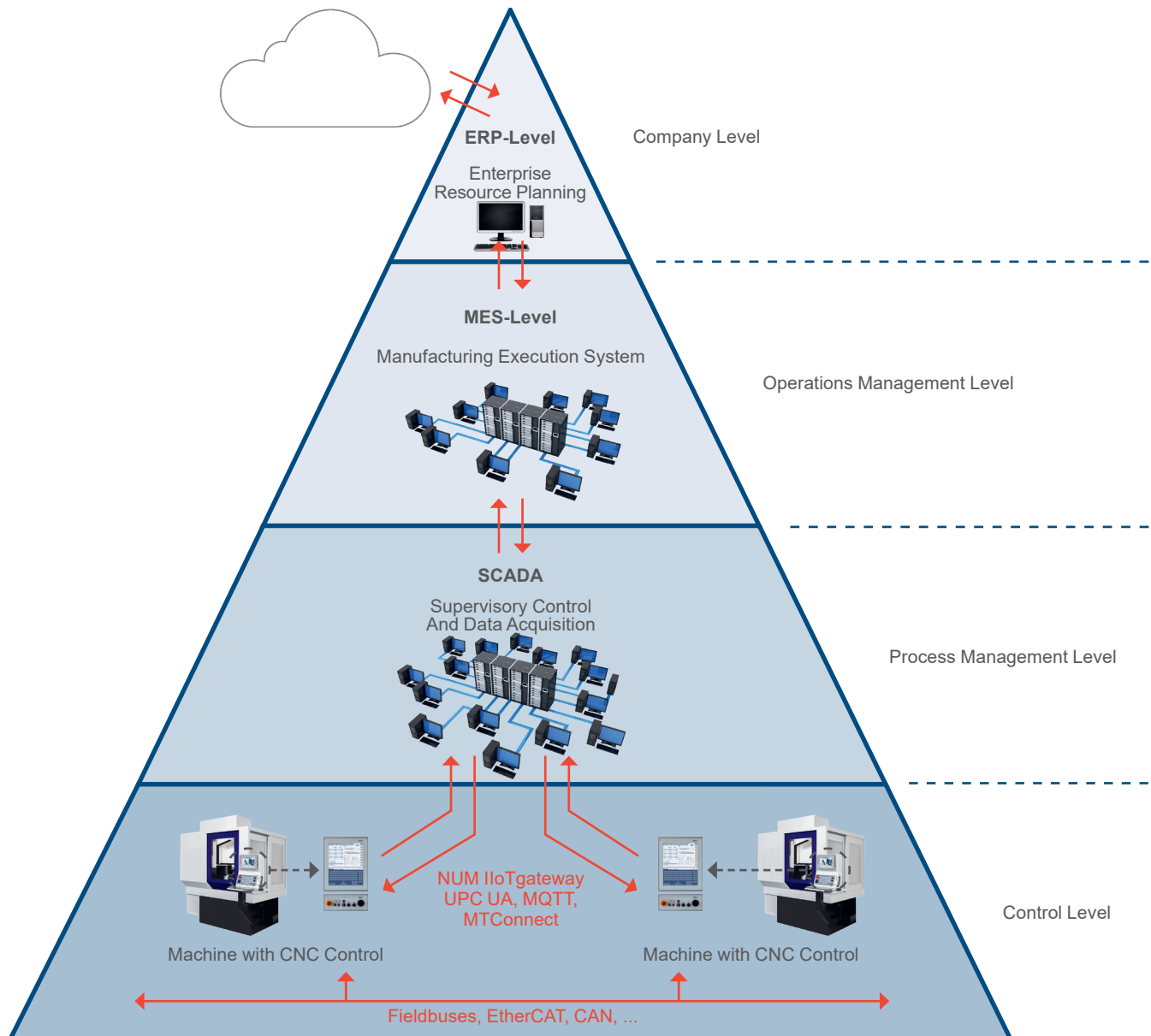





### A New Platform

The outstanding success of Flexium with over 20,000 applications completed in a short space of time paved the way for development of FlexiumPro. We took the best components, kept those elements behind the success of our previous CNCs, such as scalability, flexibility, unique CNC functions, standardized interfaces and PLC programming, then renovated and improved the complete system. FlexiumPro has new and enhanced features, new panels, a new HMI, an enhanced servo bus, enhanced drives and simplified connectivity – all within a completely new safety-related architecture.

2

To provide optimum cost/performance ratios, FlexiumPro exists in three configuration levels:

- FlexiumPro 6
- FlexiumPro 8
- FlexiumPro 68

**Take the most flexible CNC system (NUM Flexium<sup>+</sup>), improve calculation power, speed, connectivity and reliability and the result is NUM FlexiumPro.**

Both main processes, PLC and CNC, are now embedded and running together on a single board based on a multi-core ARM processor. The extremely high integration level, achieved by using System on Chip technology, results in a huge reduction of components which improves system reliability and availability. The hard real-time operating system reduces latency and avoids the overhead of complex “soft” operating systems. Every detail is optimized to maximize machine productivity and availability. NUM FlexiumPro is more than 10 times faster than its predecessor – CNC/PLC interface, block per second, axis task, boot time – everything become much faster, setting new standards.

NUM FlexiumPro retains and extends all NUM Flexium<sup>+</sup> behaviors and functions. For example:

- 32 axes and/or spindles
- 32 machining channels
- Nanometer interpolation
- RTCP (Rotation Tool Center Point)
- HSC (High Speed Cutting)
- Specific technology functions and machining cycles
- Improved diagnostics
- Etc.

PLC application, part programs, machine configuration, calibrations, etc., are all safely saved on a removable microSD card – and to secure shutdown processes, the NUM FlexiumPro RTK (Real Time Kernel) integrates a super-capacitor, which keeps the system alive for the time needed to save all data in the case of hard power off. OEMs used to Flexium<sup>+</sup> will easily migrate to FlexiumPro. The FlexiumPro PLC programming languages and environment are identical to Flexium<sup>+</sup>, part programs remain compatible with both systems, software interfaces to OEM’s custom HMIs (Human Machine Interfaces) remain very similar, EtherCAT terminals and safety devices are unchanged. To overcome the limitations of the standard servo drive device profiles of EtherCAT, NUM has decided to use a custom one. The need to exchange floating point variables, 64 bits position data and offsets, multiple parameter structure etc. could not be achieved with a standard device profile.

Highlights:

- Multi-core ARM architecture with hard Real Time Operating System
- High level of integration thanks to System on Chip technology
- CODESYS V3 embedded PLC
- The use of industrial PC is suggested but not mandatory (no real-time on PC)
- EtherCAT fieldbus for servo drives, I/Os and safety (with Fail Safe over EtherCAT)
- Extended PLC/CNC interface
- Faster CNC/PLC exchange
- Extended high speed and real time data capture (to further improve NUM solutions for process monitoring, edge computing, condition monitoring with AI, etc.)
- Removable micro SD card to store all machine data, application, part program, retained variables
- New Human Machine Interface, running on Windows OS, which can be customized by OEMs/users (see dedicated article)
- One commissioning tool for entire system: PLC programming, CNC/Drive configuration and tuning, safety programming etc.
- Super-capacitor to avoid data loss during hard power OFF
- NUM FlexiumPro RTK has a fan-less and very compact design (25 mm width)
- CNC more than 10 times faster than predecessor
- Faster boot time

The single development environment provides different access levels for machine integration, setup and maintenance.



## Safety

---

A key distinguishing feature of Flexium<sup>+</sup> is its safety architecture, NUMSafe. NUMSafe components and architecture remain for FlexiumPro too.

In short, a safe PLC, intimately integrated with the standard PLC, using FSoE (Fail Safe over EtherCAT) protocol, communicates with safe inputs and safe outputs, as well as with the new NUM DrivePro where the safe motion monitoring functions are implemented and executed.

NUM DrivePro, featuring the new NUM-SAMX functional safety board is a key component of this solution. It maintains all of the superlative and well known characteristics of NUMDrive X – performance, scalability, modularity, reliability ...- and drives them even further.

The programming environment is provided for both “safety related” and “non safety related” logic.

## Flexibility

---

This recognized characteristic of NUM products has now been advanced even further. Any of the 32 devices connected can be alternatively an axis or a spindle. This makes spindle/ C axis commutation even easier but more importantly it opens the door towards new possibilities, sophisticated transfer machines being one among many.

As a direct consequence a single CNC is now able to control up to 32 spindles. Among the four spindles of each channel one will be the main on which all advanced functions (CSS, Threading ...) will be performed, the three others being declared as auxiliaries. They are controllable in speed, direction and indexing. And of course, exchanging spindles or axes between channels or declaring a new main or auxiliary spindle is just an M code away. To further extend the system's flexibility, FlexiumPro can now manage up to 32 machining channels with a single FlexiumPro RTK.

## Productivity

---

Among other new features, the CNC computing power has been increased by a factor 10, resolution and bandwidths increased significantly, with more and faster inputs and outputs made available. Unified firmware for Mono-axis, Bi-Axes and Quad-Axes drives makes version management even easier.

Last but not least, thanks to an innovative communication protocol that handles encoder power and data on just two wires, the encoder cable has become unnecessary and therefore was completely removed. Motors and drives can now be linked with a single cable, saving time and money.



### NUM FlexiumPro System Architecture

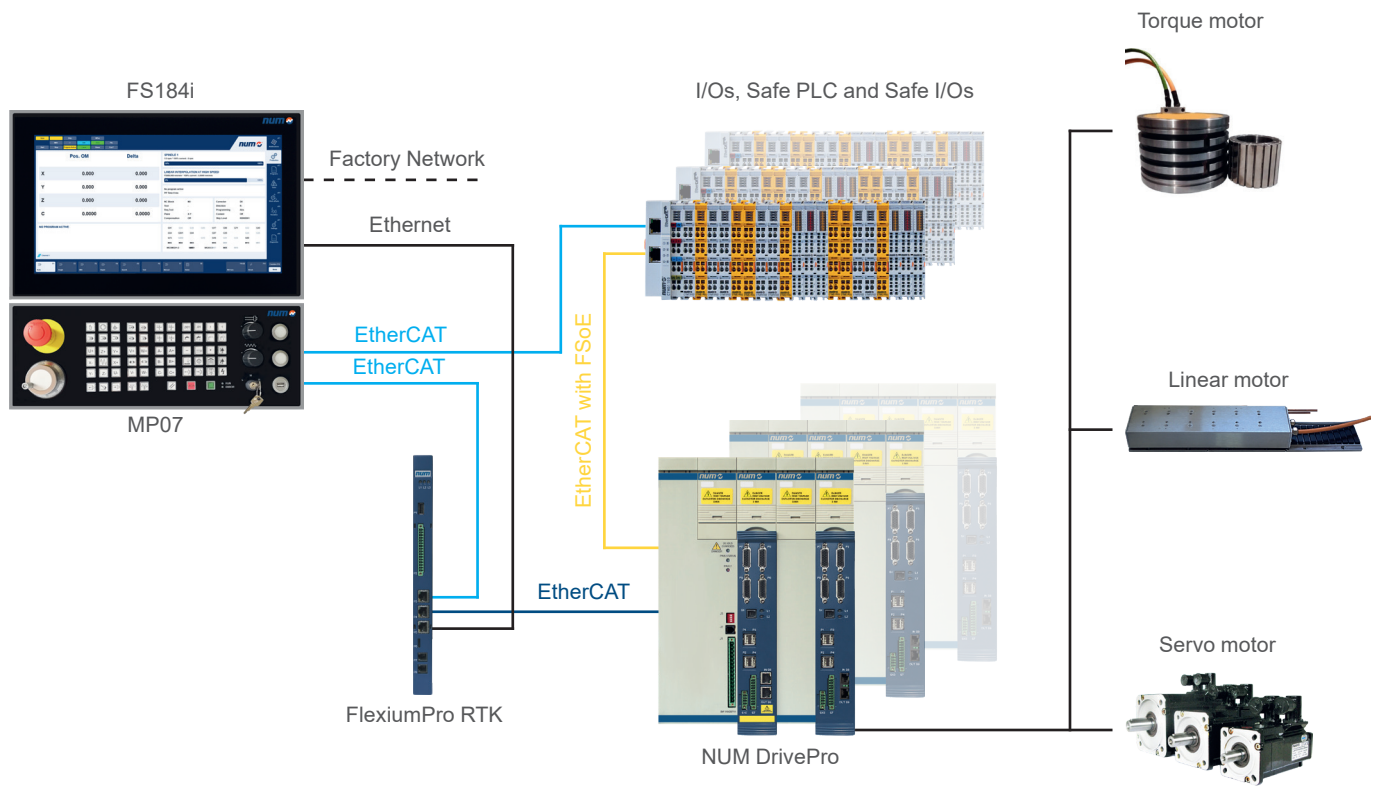



---

## Axes Structure

One FlexiumPro NCK provides up to 32<sup>1</sup> channels, each able to handle up to nine axes, a main spindle and 3 auxiliary spindles. Each channel runs its own part program at its own pace, with the possibility of synchronization when necessary. Thanks to the advanced programming function, this structure offers numerous possibilities, including the ability to pass control of one or more axes from one channel to another on the fly. Moreover, the different channels can also function totally independently. This is almost like having several NCKs.

---

## Speed and Accuracy

There is no longer any need to make compromises between extended travel and high resolution, or between fast traverse rates and high accuracy. New algorithms have been implemented to push the limits in every direction. Detailed technical characteristics are described in this catalog.

---

## Axes Control

Enhanced acceleration algorithms allow, thanks to the increased resolution, fine tuning of the jerk value for optimal block transitions while limiting mechanical stress.

The different tools to optimize and check the servo response are integrated in the FlexiumPro Tools development package. In close association with the digital drives, they provide monitoring of the drives' internal values, oscilloscopes to check all kinds of responses, a Ballbar <sup>2</sup> function, Contour accuracy checking to verify machine reaction in a specific part of the machining cycle, and many other functions.

---

## Programming

To control these new functions the part program structure has been reviewed, taking advantage of the 40 MB available.

Block numbering has been extended, and enhanced search capabilities have been provided. Direct editing facilities, in conjunction with backtrack and resume functions help interaction when necessary on long machining operations.

Emergency retract, either manually or automatically generated, is an important feature to protect people and material, should anything go wrong. More details about the programming features are given in Chapter 4.

---

## Machining Packages

The range of specific machining packages or functions is expanded. In addition to the current Turning, Milling, Grinding (OD or surface), Gear hobbing, Shaping, etc, NUM is introducing new jet cutting functions. These include a 'tilted nozzle management' function that automatically compensates for the conical shape of the beam.

And much more:

The following pages will describe the other components of the system. It is however not possible to define in a few pages all the advantages FlexiumPro could bring you. Don't hesitate to contact us - we will be happy to demonstrate our products in more detail so that you can understand why NUM, your partner, is truly a High End CNC application provider.

---

## Vibration Detector (VDR)

NUM vibration detector (accelerometer) can be directly connected to NUM DrivePro and it's sampled at 50 microseconds.

---

<sup>1</sup> One Channel up to 4 axes and 1 spindle for FlexiumPro 6

Up to 2 channels and up to 5 axes, or 4 axes and 1 spindle, for FlexiumPro 8

<sup>2</sup> Ballbar function is intended to measure and therefore correct trajectory error (sticking, quadrant transition, radius) in circular interpolation



### FlexiumPro RTK (Real Time Kernel)

FlexiumPro RTK is the heart of the system. It is based on a Multicore ARM architecture with hard Real Time Operating System and integrates all real time components: PLC (CODESYS V3) and CNC.

By means of EtherCAT it can pilot up to 32 axes driven by NUM DrivePro servodrives.

A dedicated EtherCAT field bus is used for connecting I/O terminals and peripherals, Safe PLC and Safe I/Os (with Fail Safe over EtherCAT). As alternative, CANopen field bus is also supported.

FlexiumPro RTK locally integrates analogue outputs and inputs, 4 fast digital inputs (for probing) and 4 x opto-isolated outputs.

Super capacitors, which keep the system alive, avoid losing data during hard power off cycles.

Chapter 4 describes the firmware functions and the options in more detail.



### Panels FS122, FS154i, FS184i, FS244i

NUM PC panels (FS family) are industrial solutions used as human machine interface (HMI). Different versions of panels are available from 12" up to a 24" display size. The newer FS184i and FS244i operating panels provide a durable, modern front end for machine control. They have an IP65 degree of protection at the front, and IP20 at the rear. High-quality anti-glare glass protects the front, without introducing any disturbing reflections.

To improve ergonomics, easiness of use and comfort, NUM has completely re-designed the FlexiumPro HMI software. All HMI context levels have been adjusted to a new design for improved usability and operator convenience. The FlexiumPro HMI pages can be customised by mean of a configuration tool.

For users who want to run their HMI on a different PC, NUM offers a software option (FPHE557300)





In addition to the active panels shown on the previous page, NUM offers a number of companion products for human-machine interaction.

### MP06

MP06 includes 60 configurable buttons with blue LEDs, 2 Overrides potentiometers or selectors for spindle speed and feed rate, 1 Handwheel (as optional), 1 Emergency stop button, 1 Three-position key switch, 3 Dedicated buttons. The design fits with the FS154i family and it's connected with EtherCAT.

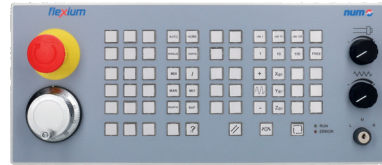

### MP07

MP07 includes 60 configurable buttons with blue LEDs, 2 Overrides potentiometers or selectors for spindle speed and feed rate, 1 Handwheel (as optional), 1 Emergency stop button, 1 Three-position key switch, 3 Dedicated buttons, a USB connector (extension). The design fits with the FS184i family and it's connected with EtherCAT.



### MP08

MP08 has got identical characteristics as MP06, the only differences are: smaller width dimension to fit FS122 panels and E-STOP button and handwheel are not foreseen

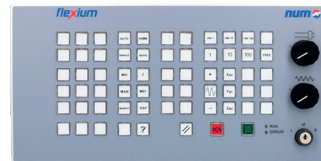

### HBA Portable Handwheel

Suited for manual control of the axes, this unit combines an electronic handwheel, two selectors, three pushbuttons and a three-step dead-man's button, in an ergonomic enclosure.

Detailed characteristics of the panels are contained in Chapter 3.



### Vibration Detector (VDR)

NUM vibration detector (accelerometer) can be directly connected to NUM DrivePro and it's sampled at 50 microseconds; as well as for measuring accelerations it can be used in closed loop to damp machines vibrations.





# FlexiumPro CNC System

## FlexiumPro System Overview Components

### FlexiumPro HMI

The FlexiumPro HMI runs on NUM industrial PCs or any other PC<sup>1</sup>. It is organized in several contexts and is a very intuitive interface for interacting with the machine. Function keys located on the bottom and right side of the screen allow direct and quick access to all relevant functions and menus.

The new modern design improves user interaction and thanks to a power SDK (Software Development Kit) NUM FlexiumPro HMI can be adapted, completed, modified, and customized. To integrate specific technology-related features, FlexiumPro HMI modules can be developed; the pages' layout is constituted by "areas" and each "area" contains a two-dimensional grid where modules can be placed. A graphical configuration tool allows customizing/creating modules to be placed on the different HMI pages FlexiumPro HMI runs on Windows operating systems FlexiumPro HMI can run directly connected to a FlexiumPro RTK (Real Time Kernel) or remotely connected on whatever PC belonging to the same LAN of the FlexiumPro RTK.

2

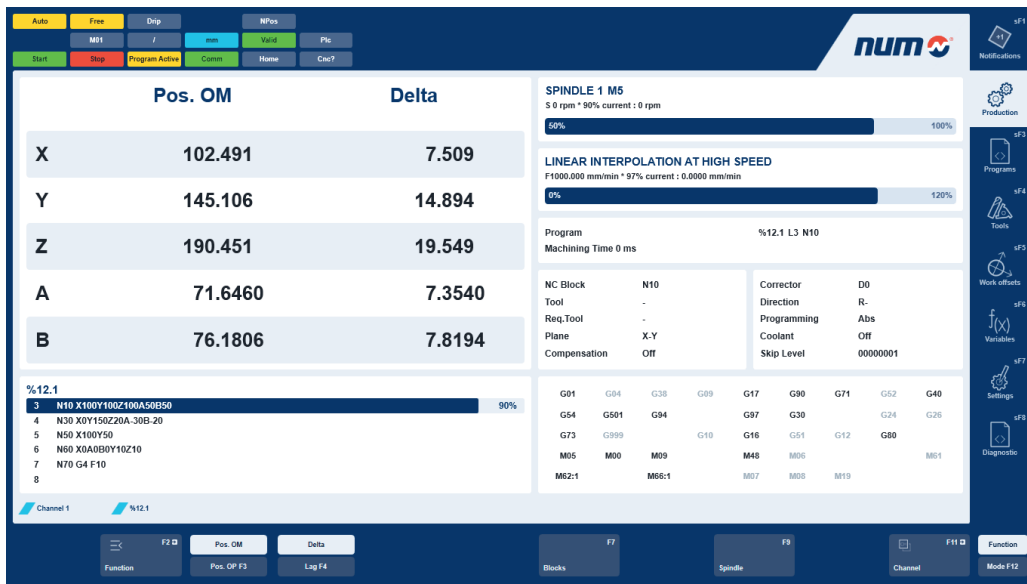

<sup>1</sup> In case a third party PC is used option FPHE557300 is required



### Flexium 3D

Providing fast and accurate 3D simulation, Flexium 3D is a graphical simulation software for part programs written in ISO-code (DIN 66025 with NUM extension) suited for different applications like milling, drilling and/or turning, as well as water jet and plasma cutting, etc. Other structures of machines can be created using the embedded machine editor.

It is available in two versions:

- Office version: Flexium 3D can be used as a standalone program in production planning, without a CNC, to verify and optimize manually written or CAM generated part programs with direct source reference
- Machine version: here, Flexium 3D forms an additional part of the FlexiumPro HMI and is connected to the CNC. Flexium 3D can be used either to pre-simulate part program (even during processing of another) or to provide synchronous online simulation during part processing

During part program simulation you can visualize the path of the TCP (tool center point), simulate material removal from the work piece, and check for collisions between machine components, part and tool.

It exists in different configurations for milling, turning, as well as waterjet and plasma cutting:

- Turning: 3-5 axes simulation of part programs. Includes simulation of grooving, thread cutting and tapping movements and cycles
- Milling/drilling: 3-axis simulation of part programs. Includes simulation of standard milling and drilling cycles (4 to 5 axes simultaneous processing with RTCP and inclined plane are supported)
- Cutting: 2D/3D visualization of cutting contour. The configurable moving zoom window of the tool center point environment is used to illustrate local contour when comparing huge work pieces

Main features of Flexium 3D simulation:

- Wired path simulation (standard)
- Workpiece and Machine view (standard)
- Material removal
- Collision detection
- Tool Editor (standard)
- Blank Editor (standard)
- Machine Editor (standard)
- Online simulation
- SEARCH Mode (graphical supported part program Re-engagement)
- 3D-Path Editor (Contour reworking/path optimization)

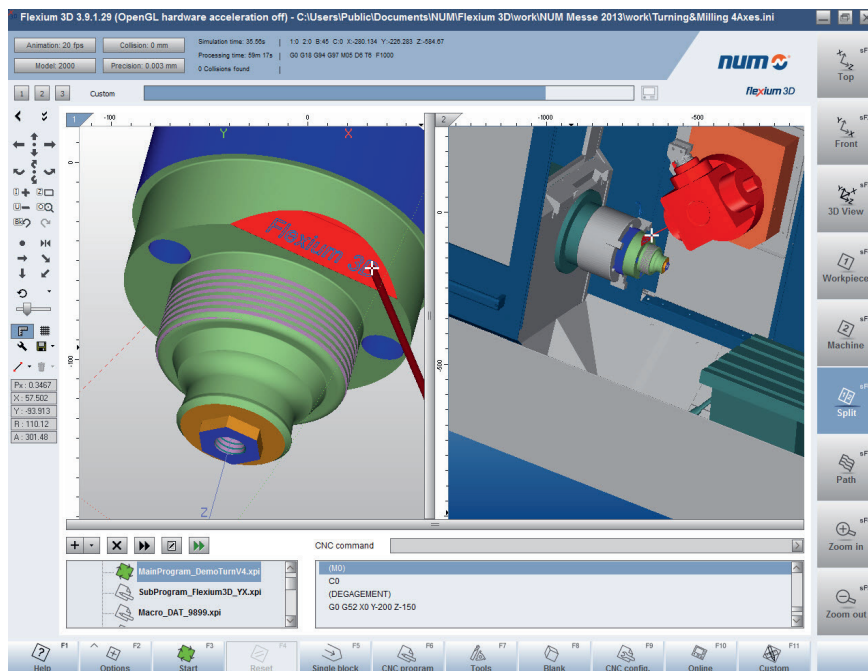

## NUM DrivePro

One distinguishing feature of the latest NUM's servodrives is its high power density. NUM DrivePro offers an enormous amount of computing and drive power within a very small space and thus have one of the highest power/volume ratios available. A high degree of integration and efficiency has allowed us to achieve an extremely compact design that makes NUM DrivePro one of the smallest high-end drives on the market. Thanks to a small depth and a modular width (a multiple of 50 mm) the cabinet layout is greatly simplified.

Like NUM FlexiumPro, the NUM DrivePro control unit has a very high integration level, thanks to the use of System on Chip technology incorporating a multi-core ARM processor. To avoid latency and overheads, there is no operating system between the CPUs and the software – it is bare metal programming. As a result, the NUM DrivePro control unit can pilot up to 4 axes simultaneously, with a position loop sampling time of 50  $\mu$ s.

The range is characterized by a wide choice of current from a few amperes up to 282 Arms, Bi-Axes versions are available up to 2x53 Arms, Quad-Axes versions are available up to 4x10 Arms to enable each application to be optimized at the lowest cost. For the maximum contour precision, speeds and cost-effectiveness, the NUM DrivePro servo drives can be exactly adapted to the particular machine and application.

NUM DrivePro is a modular system that is optimized for multi-axes applications. Use of a common power supply unit means that only one mains connection, one line filter and one braking resistor are required per system, reducing cabling and overall costs. The system's modularity also facilitates energy exchange between different axes via the DC bus, offers the possibility of using stored energy for retraction purposes, and – in the case of regenerative power supplies – allows energy to be re-injected into the mains to reduce machine operating cost. Such system conception also leads the way for a greener approach.

NUM DrivePro offers a choice of two performance levels:

- Standard-Performance (SP) drives
- High-Performance (HP) drives

Featuring high internal resolution, a short sampling time and specially developed algorithms, the HP versions are designed for sophisticated and complex applications in precision machine tools. The position control loop is closed with a very high bandwidth, achieving exceptional precision and speed at the mechanical interface of the machine (motor axis, linear motor). NUM DrivePro accepts almost all measuring systems (up to 3 sensors per axis; 2 encoders + accelerometer) and can control a broad range of motors (servo, torque, linear, asynchronous motors) from NUM or other manufacturers. This ensures that a solution can be optimized from the technical and economic perspectives.

The HP versions of NUM DrivePro also incorporate unique functionality known as DEMF (Drive Embedded Macro). This allows users to create their own real-time macro which can interact with all physical and virtual drive resources – even to the extent of manipulating the regulation algorithms. Users can design and implement filters and monitors, define test points and create pilot outputs that obey user-stipulated rules.

DEMF is an option and can be ordered using NCK option FPSO000456.

The SP versions of NUM DrivePro are suited to systems and precision machine tools of medium complexity, as well as cost-sensitive applications.

Within the NUMSafe architecture, NUM DrivePro provides the safe motion functionalities by means of two different modules:

- NUM-STOX is the basic module for implementing the Safe Torque Off function certified up to SIL 3 according to IEC 61508. This allows the realization of E-STOP functions category 0 and 1 according to EN60204-1
- NUM-SAMX is the extended functionality module which provides a huge number of safe motion monitoring functions. STO Safe Torque Off, SLS Safely-Limited Speed, SOS Safe Operating Stop, SS1 Safe Stop 1, SS2 Safe Stop 2, SLP Safely-Limited Position, SDI Safe Direction, SCA Safe Cam and SSM Safe Speed Monitor

Every machine builder has experienced the complexity of encoder wiring and knows that it takes time and effort to install and debug satisfactorily. The previous NUM Drive generation already introduced a revolutionary innovation to overcome these issues. The drive incorporates a full digital encoder interface which uses a two-wire communication protocol. The two wires are integrated in the power cable which eliminates the need for a separate sensor cable. For more detailed characteristics on such encoders please refer to the Motors chapter.

NUM DrivePro is optimized for single cable motors.

## Motors and Encoders

NUM produces a diverse range of brushless motors, all of which feature high power-to-weight ratios and superb dynamic performance, enabling solutions to be perfectly tailored to each application. In conjunction with NUM DrivePro servo drives these motors offer high speed and power capabilities, as well as excellent stability even at very low rotational speeds. The motors are fitted with robust optical encoders of different resolution/accuracy levels to fit the requirements of the machine and the application. As already indicated in the NUM DrivePro section, the newest motor ranges SHX and SPX integrate a revolutionary encoder which on two wires only handles the encoder supply voltage, as well as high resolution position, redundant position (for safe applications), motor thermal sensor and diagnostic data. This solution eliminates the need for a separate encoder cable, so there is no longer any need to crimp and solder a large number of wires. The power cable merely contains two additional shielded wires, which are connected to an industrial USB connector to be plugged on the NUM DrivePro. Aside from reduced installation time and cost, other advantages include reduced cabling costs, smaller cable carriers, lower moving masses, better reliability and electromagnetic immunity, and higher resolution control.



## PLC and I/Os

### The PLC

---

The PLC of the FlexiumPro system is programmed in accordance with IEC 61131-3. Thanks to the five languages available in the programming suite, FlexiumPro Tools, the most complex applications can be handled quickly and efficiently.

This development environment offers dedicated tools for development, commissioning and maintenance.

The complete machine project is defined graphically, using several wizards to help set up the drives, I/Os and CNC. The PLC program editors can be opened in the following languages:

- Instruction List (IL)
- Ladder (LD)
- Function Block Diagram (FBD)
- Structured Text (ST)
- Sequential Function Chart (SFC)

**In order to protect their specific know-how, customers can create their own compiled libraries in addition to all standard libraries provided.** The functions included in such libraries will be considered as 'black-boxes'. They will perform the functions they are intended for but none except the creator will have access to the code inside.

A FlexiumPro project contains all the data to run a machine (machine structure, components, parameters, programs) which helps restore the machine to an operational condition should anything go wrong.

### FlexiumPro I/Os

The FlexiumPro I/O system is based on EtherCAT (Ethernet for Control Automation Technology). This real-time Ethernet technology is standardized by the EtherCAT Technology Group. In addition to its large acceptance and fast speed, EtherCAT opens the way to the Safe architecture NUMSafe thanks to the FSoE<sup>1</sup> protocol.

### EtherCAT Protocol Process

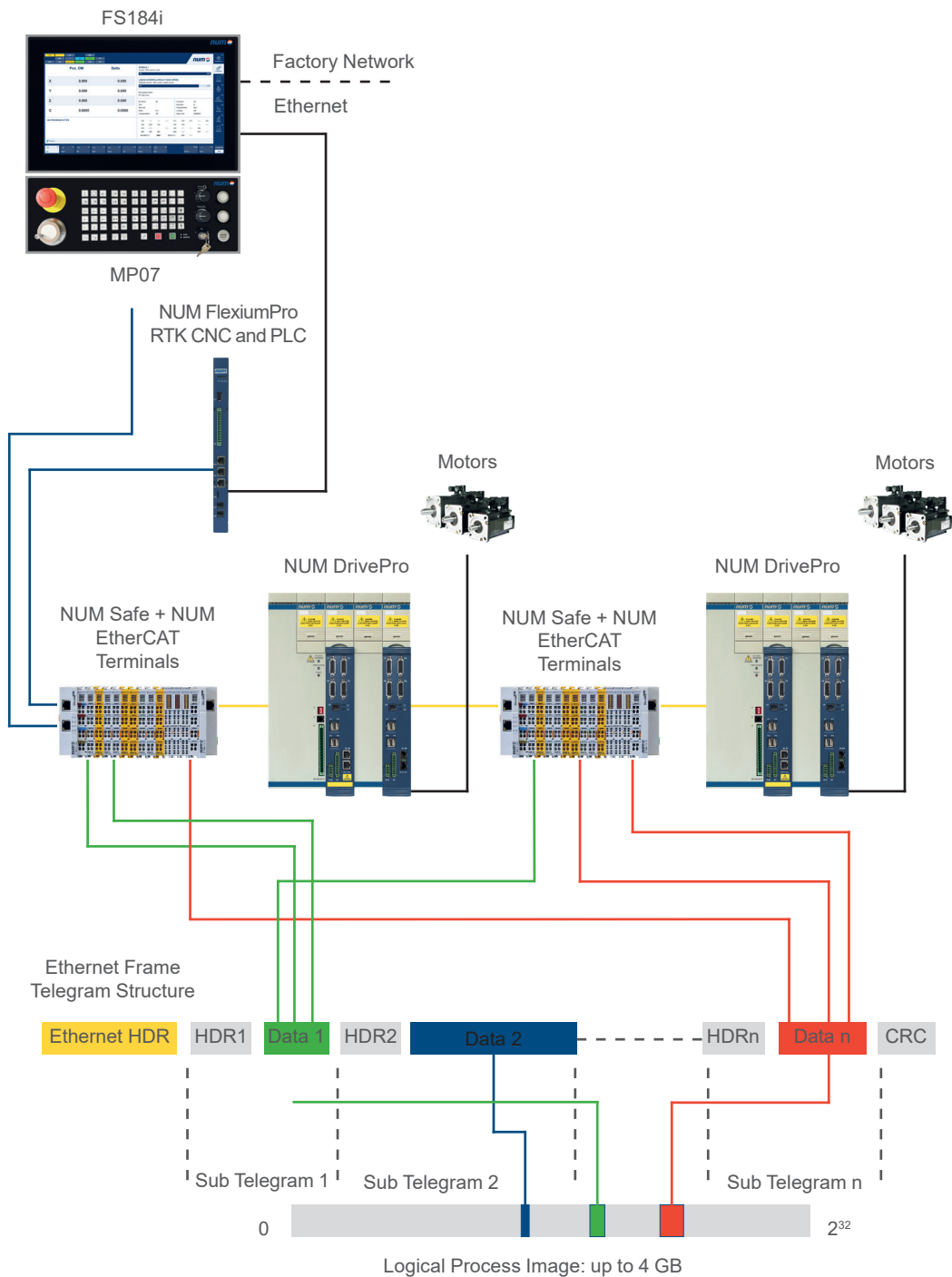

<sup>1</sup> FSoE: Fail Safe over EtherCAT



## FlexiumPro Tools

---

FlexiumPro Tools software runs on Windows operating systems and includes all functions needed for the integration and commissioning of machines. Under a unique environment, it allows users to declare, parameterize and adjust all system components.

- FlexiumPro NCK (CNC)
- PLC structure (I/Os) and program
- Servo drives and motors
- Sensors
- EtherCAT and CANOpen gateways with a comprehensive set of I/Os and logic terminals

### Easy Operation

The menu structure of FlexiumPro Tools provides a perfect overview of the entire system. The different devices are displayed under a tree structure allowing easy access to all functions for online visualization and settings.

### Project Handling

Access rights can be defined for different users. Each project consists of one single file to ensure easy handling and to prevent data losses. New equipment or versions are quickly integrated using Electronic Data Sheets (EDS) for I/O devices and Device Descriptions (DevDesc) for NUM devices. Libraries can be used in different versions and can be compiled to protect know-how. Complete projects, including libraries, devices and the source code can be archived, thus making restoration possible at any time in the future.

### PLC System Programming

The PLC of the FlexiumPro system is programmed in accordance with IEC 61131-3 and supports different graphical programming environments.

The logical and easily manageable development environment offers dedicated tools for development, commissioning and maintenance. The PLC program structure is displayed in a logical structure showing the different blocks and folders. The program editors can be opened in the following languages:

- Instruction List (IL)
- Ladder (LD)
- Function Block Diagram (FBD)
- Structured Text (ST)
- Sequential Function Control (SFC)

The PLC provides libraries for system functions, customer functions and its own programming functions.

Task management is very flexible with tasks that can be cyclic, event-controlled or freewheeling.

Data and variables are based on of a high level language. Data types can also be user defined.

The program can be easily structured using program building blocks, functions and function blocks with entities.

Object oriented programming is also supported and allows safe programs using objects, methods, properties, actions, interfaces and inherit functions.



#### **FlexiumPro RTK (CNC) Parameterizing**

Dedicated editors for options, programming, memory, channels, axes (with individual windows for settings, coupling, kinematics, travels, servo system, HSC) miscellaneous hand wheels, axes calibration and more ensure easy handling and the best overview during editing.

#### **Servo Drives Parameterizing**

All servo drives of the FlexiumPro System can be found and accessed easily in the menu structure of FlexiumPro Tools. For better overview, the device structure is displayed in the way the system is set up, e.g. servo drives are listed under the controlling FlexiumPro NCK.

#### **Field Busses**

Theoretically, any CANopen and/or EtherCAT compatible device can be connected to the bus using the EDS/ESI/XML file supplied with the device. NUM provides a comprehensive range of most common I/O components based on EtherCAT (Ethernet for Control Automation Technology). This real-time Ethernet technology is standardized by the EtherCAT Technology Group.

NUM also provides machine panels (like MP06), drives for auxiliary axes and other devices that, by means of dedicated windows and libraries, can be easily integrated as field bus devices.





## FlexiumPro and Safety

---

The NUMSafe solution implements safety technology in the FlexiumPro system. Offering a wide range of benefits in terms of scalability, flexibility and reduced wiring needs, NUMSafe also provides a common programming environment for all system devices.

Architectures with mixed standard and safety related signals and components are possible.

The NUMSafe offer consists of:

- NUMSafe PLC (CTMP6900, CTMP1960-2600),
- NUMSafe Digital Input modules (CTMS1904) and
- NUMSafe Digital Output modules (CTMS2904, CTMS2912)

Such components are positioned together with standard I/Os. By means of a NUM EtherCAT gateway they communicate with the automation PLC, with other EtherCAT gateways, servo drives and safety related components. The safety related motion functions are realized inside NUM DrivePro by means of the NUM-SAMX board.

All safety related information is transmitted over the standard EtherCAT connection, with data reliability ensured by use of a Fail Safe over EtherCAT protocol (FSoE); wiring is reduced to a minimum, while flexibility and scalability are maximized.

The available monitoring functions, according to EN 61800-5-2, are:

- Safe Torque Off (STO)
- Safe Operating Stop (SOS)
- Safe Stop 1 (SS1)
- Safe Stop 2 (SS2)
- Safely-Limited Speed (SLS)
- Safely-Limited Position (SLP)
- Safe Direction Monitoring (SDM)
- Safe CAMs (SCA)
- Safe Speed Monitor (SSM)

NUMSafe is compliant with EN13849-1 and EN61800-5-2 up to PL e and SIL 3 respectively.



## Type of Platforms

---

<b>FPP1101100</b>	<b>FlexiumPro 6</b>
<b>FPP1101150</b>	<b>FlexiumPro 8</b>
<b>FPP2101200</b>	<b>FlexiumPro 68</b>

The characteristics and content of each platform are described in Basic Features and Optional Extensions, page 74.

## Configuration

---

<b>FPSO200060</b>	<b>Turning</b>
<b>FPSO200061</b>	<b>Milling</b>

Each FlexiumPro system can be configured for milling or turning. The choice is free of charge but must be stipulated at the time of order.

The main consequences of this choice are the canned cycles and the pre-selection of the interpolation plane.

The two options can be for more complex machines under the reference FPSO000581 (later in this chapter).

## NCK Special Functions

---

<b>FPPA000599</b>	<b>NCK Digital Twin</b>
-------------------	-------------------------

The Flexium NCK Digital Twin option allows to use the NCK with emulated drives; the NCK interoperates with the PLC like if the axes/drives are physically present. It's also possible to visualize the machine movements using Flexium 3D or ISG-virtuos<sup>1</sup>. In case of ISG-virtuos we provide a PLC library and a dedicated XML for the EtherCAT connection.

## Axes, Spindles or Measure Inputs

---

<b>FPSO100006</b>	<b>6<sup>th</sup> axis/spindle</b>
<b>FPSO100008</b>	<b>7<sup>th</sup> + 8<sup>th</sup> axis/spindle</b>
<b>FPSO100012</b>	<b>9<sup>th</sup> up to 12<sup>th</sup> axis/spindle</b>
<b>FPSO100016</b>	<b>13<sup>th</sup> up to 16<sup>th</sup> axis/spindle</b>
<b>FPSO100032</b>	<b>17<sup>th</sup> up to 32<sup>nd</sup> axis/spindle</b>

These axes are directly controlled by the CNC software using a program loaded into the user memory area, or in drip feed mode for large programs (for example a CAD/CAM). Movements are generated in an X, Y, Z Cartesian coordinate system which may be supplemented by additional U, V, W axes. These axes may be independent or grouped in carrier/carried axis pairs. Three rotary axes modulo 360 degrees, A, B and C, are associated with the main linear axes.

<sup>1</sup> ISG-virtuos is a product of ISG Industrielle Steuerungstechnik GmbH



## Handwheels

---

<b>FPSO100375</b>	<b>1<sup>st</sup> Handwheel</b>
<b>FPSO100376</b>	<b>2<sup>nd</sup> Handwheel</b>
<b>FPSO100377</b>	<b>3<sup>rd</sup> Handwheel</b>
<b>FPSO100378</b>	<b>4<sup>th</sup> Handwheel</b>

A FlexiumPro system can handle up to four handwheels per NCK. Handwheels are interfaced on the fieldbus.

Handwheels can be used for manual control of axes with a possibility of four values of increments. Validated by a specific G code, they can also be used to accelerate a move (gap-elimination) or to introduce a differential shift between axes.

Several types of handwheel devices are available in our offer: standalone, integrated in a machine panel or portable (please refer to chapter 3).

## Interpolation Capability

---

<b>FPSO100335</b>	<b>5<sup>th</sup> interpolated axis</b>
<b>FPSO100336</b>	<b>6<sup>th</sup> interpolated axis</b>
<b>FPSO100337</b>	<b>7<sup>th</sup> interpolated axis</b>
<b>FPSO100338</b>	<b>8<sup>th</sup> interpolated axis</b>
<b>FPSO100339</b>	<b>9<sup>th</sup> interpolated axis</b>

According to the selected option, the system is able to move the defined number of axes in complete synchronization. The feedrate applied is defined on the linear axes; additional axes will synchronize themselves to this feedrate. As a complementary feature it is possible to define with which axes the feedrate should be computed (function G92 F...).



## Multi-Channels

FPSO100392	2 <sup>nd</sup> channel
FPSO100394	3 <sup>rd</sup> + 4 <sup>th</sup> channel
FPSO100396	5 <sup>th</sup> + 6 <sup>th</sup> channel
FPSO100398	7 <sup>th</sup> + 8 <sup>th</sup> channel
FPSO100400	9 <sup>th</sup> + 10 <sup>th</sup> channel
FPSO100402	11 <sup>th</sup> + 12 <sup>th</sup> channel
FPSO100404	13 <sup>th</sup> + 14 <sup>th</sup> channel
FPSO100406	15 <sup>th</sup> + 16 <sup>th</sup> channel
FPSO100408	17 <sup>th</sup> + 18 <sup>th</sup> channel
FPSO100410	19 <sup>th</sup> + 20 <sup>th</sup> channel
FPSO100412	21 <sup>th</sup> + 22 <sup>nd</sup> channel
FPSO100414	23 <sup>rd</sup> + 24 <sup>th</sup> channel
FPSO100416	25 <sup>th</sup> + 26 <sup>th</sup> channel
FPSO100418	27 <sup>th</sup> + 28 <sup>th</sup> channel
FPSO100420	29 <sup>th</sup> + 30 <sup>th</sup> channel
FPSO100422	31 <sup>th</sup> + 32 <sup>nd</sup> channel

In the basic version, the FlexiumPro 6 controls a single channel. FlexiumPro 8 can control two channels and FlexiumPro 68 up to 32 channels. During commissioning, the CNC axes and spindles of a machine are dispatched among all channels available by machine parameter. Part programs can later modify this configuration if authorized to. In a multi-channel system, the machining program consists of independent programs (one per channel) denoted by a common program number, followed by the channel number. A spindle declared in a channel can be controlled by that channel or be released and controlled independently.

A multi-channel system can be configured in two ways:

- **Common Mode:** all channels simultaneously in the same mode. START, STOP and RESET commands are unique. The part programs are linked by a common number. They are executed at their own pace, which can be sequenced by synchronization points.
- **Independent Mode:** when in execution, the different channels can execute different part programs in different modes (homing is always in common mode), the START, STOP and RESET commands are independent for each channel. The part programs of each channel are independently selected and do not offer a standard synchronization function.

The first channel is always an NC channel; additional channels can be configured as:

- **NC Channels:** with all functions of the first channel
- **Auxiliary Channels:** these execute a particular part program %9998.i under control of the PLC. This is very useful for machine functionalities like tool changer, pallet changer etc...



## Axes Generalities

---

Chapter 2 defines the axis configurations according to the system selected.

Axis and spindle performance is described below:

- Internal system resolution is  $10^{-9}$  meter with a maximum travel of  $10^3$  meters for linear axes and  $10^{-6}$  degrees with a maximum of  $10^6$  degrees for rotary axes (unlimited in case of modulo axis)
- The programming resolution is freely fixed from the nanometer to the 1/10 of mm for linear axes and  $10^{-6}$  degrees to  $10^{-1}$  degrees for rotary axes
- The maximum feedrate is linked to the sampling period and could go up to 1800 m/min for linear axes and 5000 rpm for rotary axes
- The spindle speed ranges from 0.01 rpm to more than 100000 rpm

## Memory Functions

---

As standard, FlexiumPro systems provide more than 40MB of dynamic memory for part programs and the different macros (User, Manufacturer and NUM). The permanent connection to the panel provides access to mass memory (hard drive or SSD) and optionally the LAN, offering almost unlimited storage capacity. From mass memory, the program can be stored in the dynamic memory for execution or it can be executed in drip feed mode (certain restrictions may apply).

The memory structure is as below. This part of the global memory can be divided into four functional areas:

- Area 0: Modifiable user area (NC memory)
- Area 1: Protected customer area
- Area 2: Protected OEM area
- Area 3: Area reserved for NUM

Each program or macro in the protected areas can be protected against display, editing and downloading. This safeguards proprietary information and guarantees the functional integrity of the machine.

### Resident Macros

Resident macros are part programs developed by NUM, the OEM or the customer himself, and are loaded into the protected memory areas. These programs are written in standard ISO language and structured programming to facilitate understanding and modification (examples: customized canned cycles).

### Editing the Macros Related to Canned Cycles

A utility included in the FlexiumPro HMI is used to retrieve these cycles for editing purposes. The modified cycles can then be retransferred to any area (other than the NUM area), where they will get a higher priority.

### Program Editing

Programs can be edited in the mass memory (hard disk) area at any time. Such modifications will be taken into account only after reloading the program in the NC.

It is also possible to edit the programs directly into NC memory in end of block stop. Such edits are taken into account immediately. This is very useful for example to change a feedrate or to correct a syntax error.

## Axis Functions

### Standard Axis Functions

#### Backlash Compensation

Positioning errors due to mechanical backlash on the linear and rotary axes are corrected automatically. The correction is related to the direction of movement.

#### Dynamic Limit Switches

The machine travels entered when setting up the machine may be dynamically limited by software. Dynamic limit switches are active in all modes.

#### Look-Ahead Function

The «Look-Ahead» function enables the NC to make a predictive analysis of the programmed path across several single machining blocks in advance. Thus, it has the opportunity to recognize the path characteristics and react accordingly. For optimal functioning of Look-Ahead, FlexiumPro NCK prepares up to 1000 blocks per NC channel to adapt the programmed feed-rate even when there are many very small NC segments.

#### Acceleration and Deceleration Control

Allows progressive as well as Jerk-controlled acceleration functions to be used for smoother mechanical operation on high-speed machines.

#### Anti-Pitch Correction

When movement on an axis is reversed, especially at low speed, this compensation prevents spikes at quadrant changes.

#### Table Eccentricity Compensation (DAT3)

This function applies to the A, B or C rotary axes. Shifting the main axes compensates the offsets due to the non coaxiality between Part Origin and the axis of rotation of the table. This eccentricity can be entered:

- On the CNC panel
- By E parameter
- By extended NCK exchange

Please note that the compensation is not continuous. It is only taken into account when the main axes are moving. A continuous correction requires a dedicated application.

#### Lubrication

The control informs in case the lubrication of an axis is required. Whenever an axis has traveled a predefined distance, a lubrication pulse is generated.

#### Free axis modulo

For rotary axes, the rollover value can be a freely definable value (not only 360°).

#### Time related M functions

- Timed M: The execution of an M function can be delayed or advanced by up to +/- 32000 ms with regard to the end of the block.
- Inter-sampled M: Such M functions are also delayed or advanced with respect to the end of the block, but they are provided on fast outputs (RTK P2) with an accuracy in the  $\mu$ s range (i.e. also between two successive real-time samples). They are used, for example, in laser cutting applications.

#### Tangential control (G748)

This function allows a rotary axis to maintain tangential orientation with respect to the programmed path in the working plane (2D).

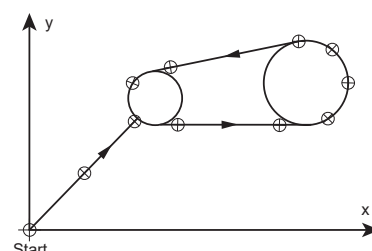



## Optional Axis Functions

### FPSO000266 Duplicated and synchronized axes

This function couples one or more slave axes with a master axis, either by setting machine parameters (fixed coupling) or by programming E parameters. It also ensures synchronization of the master axis with the slave axis (it does not include axis control).

The figure on the right shows a mechanical gantry axis pair (Z1 and Z2) and programmable gantry axis pair (X1 and X2, Y1 and Y2).

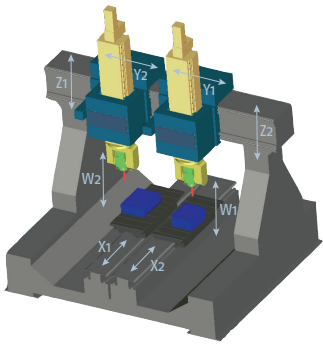

### FPSO000315 Inclined or tilted axes

On a lathe or a grinding machine, the X and Z axes can be orthogonal or inclined. The axis inclination or tilt is the angle B between the X axis (the orthogonal to the Z axis) and X' axis. Coordinate conversion takes place downstream of the interpolator. In a multi-channel system, different axis inclinations can be specified for each channel. This function is particularly used on grinding machines to work simultaneously a diameter and a shoulder without the need for interpolation.

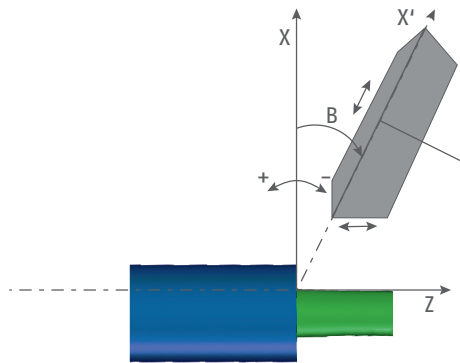

### FPSO000340 Conversion Cartesian to polar/cylindric

In this turning configuration, the spindle is used as an interpolated axis with one of the CNC axes (X or Z). A resolution of at least 90,000 points per revolution is required for the measurement sensor. The spindle motor sensor used for the speed loop must be a high resolution sensor.

### FPSO000402 Tool vector programming/3DWPC (G32/G34)

In five-axis machining, a widely used programming method is to program the articular coordinates of the rotary axes directly. Even though this makes the part program machine-dependent, this method has several advantages like a machine behavior easier to anticipate just by looking at the part program and a total absence of singularity (multiple attitudes for a single tool orientation).

Five-axis machining faces different challenges; part balancing is one of them. When a part is installed on a machine it might be very difficult to align it perfectly due to its weight, its structure, a previous machining or many other reasons. For these cases the NCK offers the possibility to compensate the deviations of the positioning (also angles) by appropriate correction values. The work piece remains misaligned but the NCK knows such deviations and compensate them by software. For this purpose, the Flexium HMI provides a special page where the corresponding correction values can be entered.

num flexium <b>®</b> b8			
Work RTCP			
Offset for Rotation around Tool Center Point			
	3D workpiece position compensation	Offset on rotary axes	
X	10.000		
Y	20.000		
Z	-50.000		
A	5.0000	0.0000	
B	6.0000	0.0000	
C	7.0000	0.0000	



The following G codes control the mentioned functions:

- G30: The part program is executed taking into account the current axis coordinates, regardless of whether the axes are linear or rotating. To take the offset into account, the part program must be edited. This is the default mode.
- G32 (Tool vector programming): In this case, the part program directly contains the tool orientation and no longer the articular coordinates of the rotary axes. This 'abstract' programming defines the orientation by the coordinates of the tool vector along the main axes. This orientation is then adjusted by the NCK according to the tilt values of the part. Finally, the articular coordinates of the rotary axes are recalculated based on this adjusted orientation.
- G34 (3DWPC): With this function, the part program continues to be written based on the articular coordinates of the rotary axes. With the knowledge of the kinematic structure, the NCK has the possibility to 'rebuild' the orientation vector of the tool. It applies the compensation to it and finally gives the adapted articular coordinates to the rotary axes. This also enables adding an inclined coordinate system with the RTCP declaration.

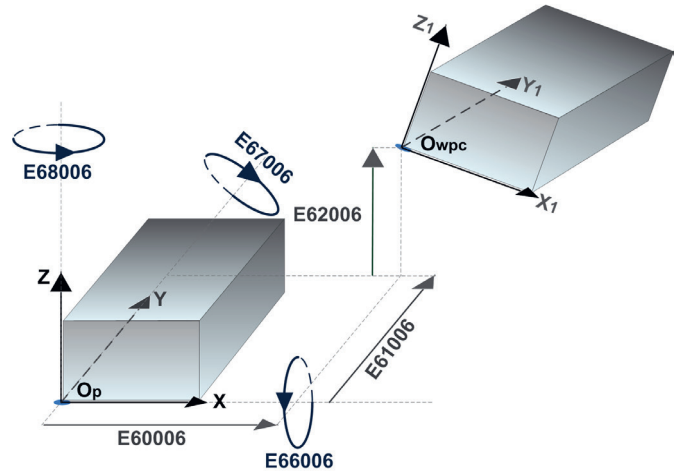

Owpc origin position shifts and Euler angles orienting the balanced coordinate system

#### FPSO000426 NURBS (B-Spline) interpolation

Geometric continuity of contours is a necessity for High Speed Cutting (HSC). NURBS (Non Uniform Rational B-Spline) curves, widely used in CAD and now on CNCs, are curves with poles that describe a contour in rational parametric form in order to be able to cut complex shapes with a minimum of contour error.

#### FPSO000518 Spline Interpolation (G06, G48, G49)

Spline interpolation is a mathematical method for smoothing curves. Spline curves are apparently continuous curves obtained by linking a series of points. With spline interpolation, the tangent is continuous and the acceleration is constant in each of the points specified on the programmed paths. Machining of a spline curve is programmed by defining:

- The points on the curve
- The sequence of execution of the curve

#### FPSO181706 Spline Interpolation with Curve Smoothing (G104)

Based on polynomial interpolation, this function allows the programmer to define curves of any shape in three dimensions, merely by defining the intermediate points.

#### FPSO000499 Smooth polynomial interpolation

Smooth polynomial interpolation allows creation of tool center paths defined by polynomials of 5 degrees or less. These paths are perfectly smooth continuous curves without segments. All the calculated points are located strictly on the curve. This type of interpolation cannot be used on modulo axes. It is incompatible with tool offsets and backtrack along the path.

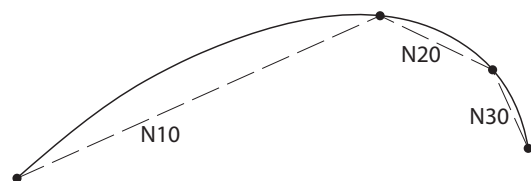

#### FPSO000461 Local contour rounding function (G164)

The tool path described by G1 linear segments, like programs generated by CAD/CAM, induces some tangency discontinuities among blocks. G164 (Local Contour rounding) allows to have a more fluid feed rate and to obtain a high and constant speed in corners. Based on the allowed cornering error, the algorithm adjusts the path. The deviation is defined by parameters.

This option needs the NCK function Smooth Polynomial Interpolation (FPSO000499).

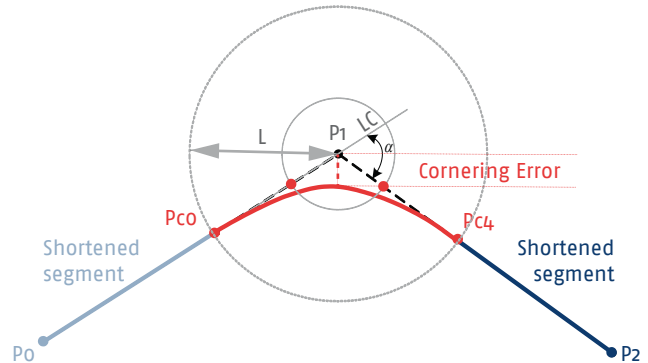

#### FPSO000462 Linear Feed Variation (G94 EF1)

For certain applications, a different treatment of the feed generation may be necessary, e.g. for water jet cutting. Here it is necessary to increase or reduce the feed at the corners using different strategies. This due to the beam deflection during the movement.

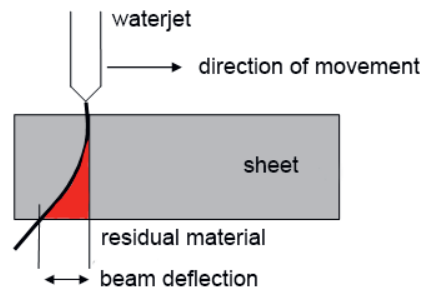

To ensure that no material is left behind, the standard feed behavior must be adjusted. The transitions between different feeds are defined as jumps. However, they are smoothed and executed with the maximum defined acceleration.

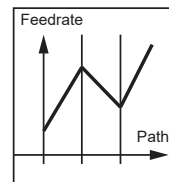
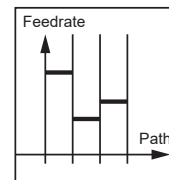

With linear feed variation, the transitions between different feeds are defined as straight lines.

#### FPSO000466 Technological Feed Adaptation (TFA)

This function was specifically developed for water jet cutting applications. In such applications the water jet lags behind (see picture of FPSO000462).

To prevent cutting inaccuracies the cutting speed has to be lowered before curves or corners, so that the contour error remains within a desired value. With Technological Feed Adaptation function speeds and accelerations are modulated in function of technological aspects.

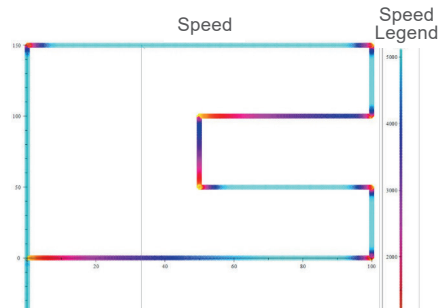

#### FPSO000467 Automatic Offset Compensation (AOC)

As the previous one, this function was specifically developed for water jet cutting applications; the kerf width depends on the nozzle diameter used but also depends on the cutting speed. Any change in speed requires to adjust the tool diameter compensation, this correction is automatically carried out by the function: Automatic Offset Compensation.

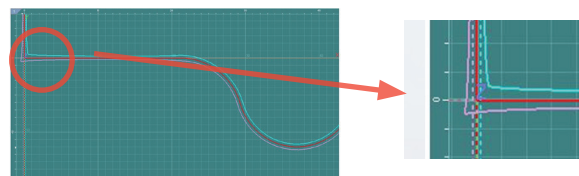

The pictures shows the feed variation.



#### **FPSW282126 Adaptive Feed Control**

The major benefits of this feature include improving the quality of ground surfaces as well as reducing the production times. This is achieved by constantly measuring and monitoring the torque of the grinding spindle as well as automatically regulating the optimal feed rate. This purely software-based “adaptive grinding” feature can be integrated in all FlexiumPro-based systems without additional hardware.

Advantages at a glance:

- Shorter production times
- Smooth surfaces thanks to constant and controlled grinding pressure
- Even wear of the grinding wheel during the process
- Permanent spindle current monitoring enable collision detection as monitoring function or avoidance of consequential damage due to overload

#### **FPSO000497 Circular interpolation by three points**

This function (G23) is executed by programming:

- The start point (defined in the block preceding function G23)
- The end point and the intermediate point (defined in the block including function G23)

#### **FPSO000514 Radial axis boring/milling function (U-axis)**

This function allows interpolation of a radial axis (Z or U) as required for a boring application.

#### **FPSO000519 Programmable precision**

The smallest unit of measurement for the display of axis positions and for position programming in a part program is 1 µm as standard. This also applies to the interface between the NCK and the drives. With this option, even 0.1 µm, 10 nm and 1 nm are possible.

#### **FPSO000699 Multi-level Electronic Gear Box (MLEGB)**

The MLEGB enables you to synchronize up to five input axes or spindles, circular or linear, into a resulting axis movement. You can combine several layers and use virtual axes as results as well as inputs. Input can be fix values as well as curve tables.

It is integrated into the NC kernel and can be used in any application. The MLEGB allows for up to 25.000 rpm on an input axis.

G770 switches an axis to spindle mode so you can run it at a defined speed. With G771 you define a gear box and activate it with G775. The MLEGB also allows for Fast Gear Alignment (FGA) integration, so FGA can run, and adjust the following gear position without offsetting the MLEGB.

#### **FPSO000463 Brake Test**

To increase machine safety is often necessary to test the axis brake before to release the motor torque.

The brake test function, if correctly parametrized, checks if the axis brake can hold the axis in position; if the brake does not meet this, the system holds the axis in position and the torque is not deactivated.

The brake test function is triggered by the PLC application; once the test is triggered, the FlexiumPro system performs it autonomously. Flexium NCK informs the PLC if the test is completed.



#### **FPSO000464 Multi-turn encoder emulation**

In case of machine axes where multi-turn encoder solutions are not available, the NCK multi-turn encoder emulation function can fix the issue. The NCK memories, in real time, the number of revolutions.

The limitations are:

- in case of hard power off, less than half encoder revolution is accepted
- if the motor is moved when system is powered OFF the multi turn counts are lost

#### **FPSO000453 Tandem function (AP03, AP04)**

This function includes two algorithms that are very useful for interdependent motors:

- Anti-Backlash compensation
- Torque duplication

(see section "NUM DrivePro Optional Functions" page 70)



## Standard Spindle Functions

---

### Spindle indexing

This function stops the spindle in a position defined with reference to a fixed point, the angle of the end position can be programmed by M function parameter (EC for milling and C for turning configuration).

### Spindle range automatic search

For spindles configured with gearing, the correct range is automatically selected by the system depending on the programmed speed.

## Optional Spindle Functions

---

### FPSO000156 Spindle synchronization

This function controls speed synchronization of two measured spindles. It is used in particular for machining operations such as parting off. Synchronization can be obtained with stopped spindles but also on the fly while the master spindle is rotating. The system will take into account the acceleration capacity of the slave spindle.

### FPSO000331 Sequenced thread cutting (G31/G38)

This function synchronizes the tool axis displacement to spindle rotation. It is required in particular for the thread chasing cycle (G31) and also permits variable pitch threading. It includes the machining cycles FPSO000695 or FPSO000696 according to the selected configuration (turning or milling).

### FPSO000332 Rigid Tapping

The infeed on the tool axis is synchronized to the spindle rotation. At the end of tapping, reversal is gradual and smooth. This function avoids the need of an axial floating tool holder. The rigid tapping cycle also allows the chip breaker function.



## Standard Machining Functions

### G20: Programming in X, Z and C polar coordinates

This function is used to program the X and Z linear axes and control a rotary C axis modulo 360 degrees. This is a standard operation.

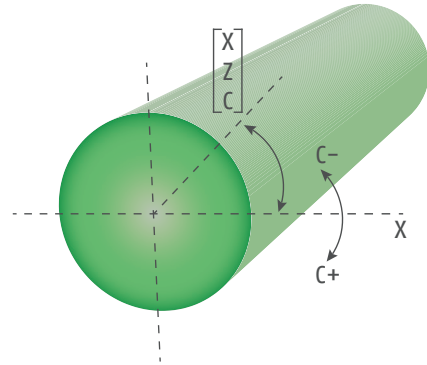

### G21: Programming in X, Y and Z Cartesian coordinates

Programming is done in a fictitious Cartesian coordinate system XY perpendicular to the spindle axis. The system performs Cartesian/polar coordinate conversion (conversion of X-Y to X-C). The X and C axes are interpolated for milling in the plane perpendicular to the spindle axis. The tool is driven by an auxiliary spindle.

G21 function has been evolved to allow milling and grinding operation when the tool and the rotating workpiece are not aligned along the axis perpendicular to X.

G21 path are subjected to look ahead velocity and acceleration control. Three feed mode are possible: Constant tool centre feed, Constant contact feed and constant C axis rotation feed.

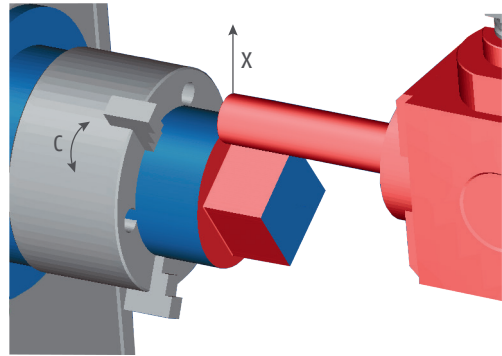

### G22: Programming in X, Y and Z cylindrical coordinates

The system performs cylindrical/polar coordinate conversion (conversion of X-Y to Z-C). The C axis is interpolated for milling on the involute of the cylinder with radius X. The tool is driven by an auxiliary spindle.

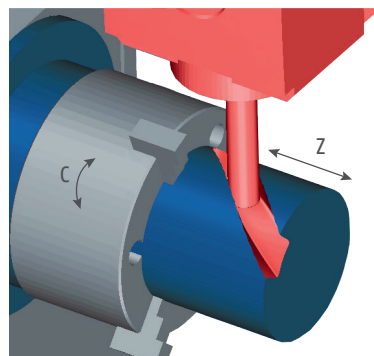

## Optional Machining Functions

### FPSO000154 Rotation Tool Center Point (G26 RTCP)

The RTCP function can be used with all known five-axis machine structures.

It provides automatic compensation on the main machining axis for the offsets caused by movement of the rotary axes of a five-axis machine. This compensation preserves the position of the center of a ball-end tool during interpolation.

The RTCP function is parameterized using FlexiumPro Tools. The installation program generates a macro containing a description of the machine's kinematics.

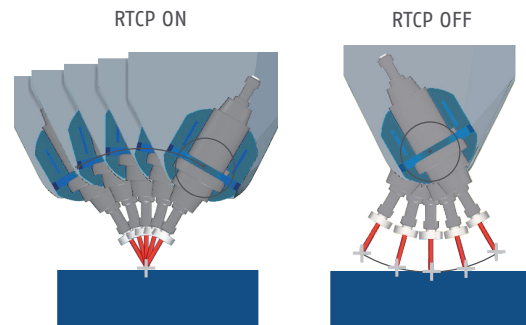

### FPSO000155 High Speed Cutting (HSC)

This function practically eliminates the following error, even at high machining speeds. This is achieved by the following mechanisms:

- Total speed anticipation
- Acceleration anticipation
- Anti-pitch correction: when machining circles, the friction torque appears as dynamic backlash when reversing direction; the adjustable correction compensates for this friction torque
- Gradual acceleration with controlled jerk-rate derivative
- Accurate feed control based on upcoming changes in the machining path

This control requires evaluating the curve radius over a sufficiently long section of future path (horizon). It also requires detecting and evaluating the sharpness of corners which may exist on this segment of path. For form machining, up to 1000 blocks per channel can be pre-analyzed.

### FPSO000581 Combined machine (turning + milling)

This option includes the basic milling functions plus several functions for controlling a combined machine (milling + turning):

- Axis/spindle synchronization
- Support of a radial axis (drilling)
- Cartesian/polar coordinate conversion
- Turning cycles





#### FPSO000695 Milling cycles

##### Milling Cycles (G45, G81 to G89)

The milling cycles can be called from the main machining program:

- Drilling (center drilling, counter boring, peck drilling, drilling with chip breaking), tapping
- Various types of drilling
- Other cycles: thread chasing, etc

These cycles are provided by ISO subroutines (macros) that can be edited. The standard set can be customized for the type of machine and job for which they are used.

If the option FPSO000331 is activated these cycles also include the thread chasing cycle (G31). It is also possible to create special cycles. These cycles can then be called from the main program by G functions.

##### Rectangular and Oblong Pocket Cycles (G45)

These cycles facilitate execution of circular, oblong, rectangular and square pocket cycles.

##### N.B.: Customized Cycles

It is possible to create additional cycles that are specific to an application or a machine. These cycles are then called by new G or M functions. For G functions, it is possible to create programs %10100 to %10255 and call them by functions G100 to G255 respectively.

For unassigned M functions, a machine parameter, 'subroutine call by M function' is used to call a program number defined at installation when the M function is detected in the part program.

#### FPSO000696 Turning cycles

##### Turning Cycles (G63 to G66, G81 to G87, G89)

These cycles can be called from the main machining program:

- Groove roughing, face-turn roughing, plunging
- Drilling (center drilling, counter boring, peck drilling, drilling with chip breaking), tapping
- Drilling cycles

These cycles can be edited and special cycles can be created. They are called by G functions (see Customized Cycles above).

#### FPSO100538 Polygon-cutting cycles

This turning function is used for cutting flats or polygonal shapes on the surfaces of parts of revolution. The cutting technique is based on synchronization of a rotary axis with a spindle rotating in the same direction with a programmed speed ratio.

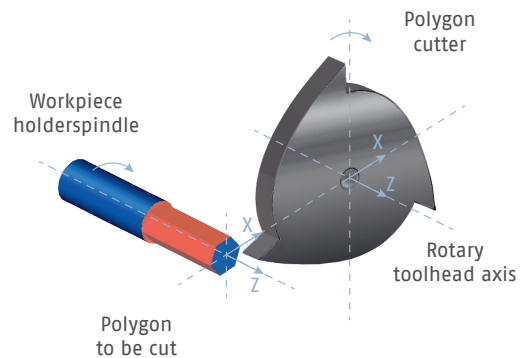



#### FPSO000700 Trochoidal Milling Cycle (G725)

A Trochoidal/cycloidal motion is the curve that describes a point on the circumference of a circle when the circle moves along a straight line.

Trochoidal milling is a specific strategy for milling that uses new CAM programming systems and control cycles to achieve consistent tool engagement, higher material removal, and a consistent average chip thickness. As a result, optimum and effective machining processes are guaranteed.

This feature is called Trochoidal Milling Cycle and can be started with G725 in NUM ISO programming with different cycle parameters including feed definition.

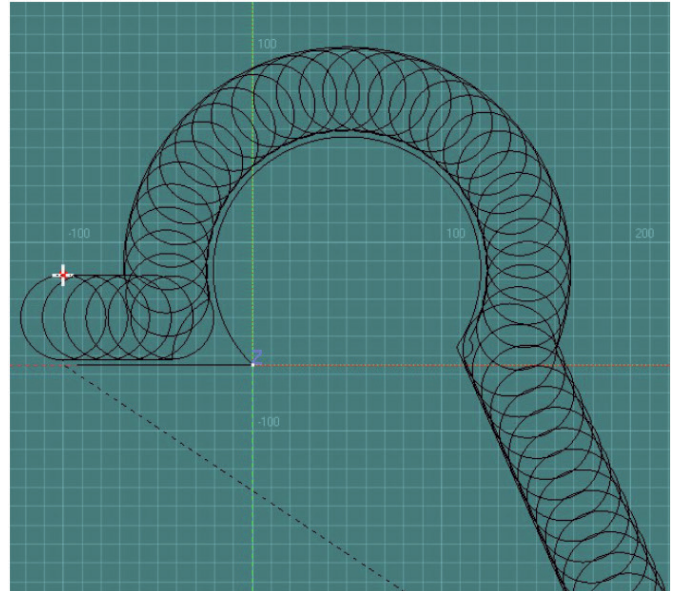

#### FPSO000701 Engraving Cycle (G730)

The G730 cycle is used to engrave characters from a string of text by interpolating the axes in the machine. The symbols that are available are the uppercase and lowercase letters (A-Z and a-z), number from 0-9 and some special characters.

It is possible to write text in a straight line, with an inclination, or along the circumference of a circle with radius R. Each letter can also be rotated by an additional angle (inclined character).

This engraving cycle allows the end user to write some text (such as a ID, serial numbers, piece coding or date and time) on the work piece without using a CAD/CAM system or any other software tool.

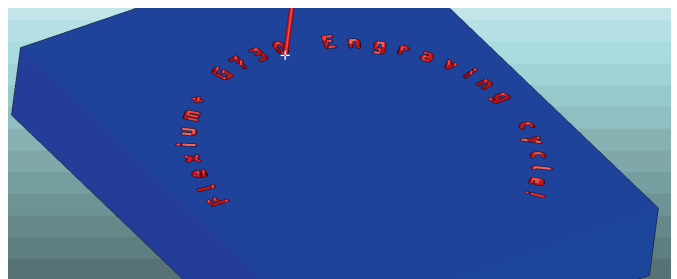

#### FPSO000404 Tilted Nozzle Management (TNM)

This feature is mostly used for jet cutting applications. It is intended to take into account the fact that the cutting head is not always perpendicular to the interpolation plane by recalculating the angles and continuously repositioning the nozzle to keep the same inclination.

The nozzle orientation vector, that will finely reposition the head, is defined by two curves figuring the jet center path at the top of the part and at the bottom of it.

- At the top, the trajectory is created from the program trajectory like for the usual G41/G42 compensation
- At the bottom the trajectory is offset by the value of the jet radius + the tilting effect (nozzle angle along the part height)

Depending on the type of crossing it may add an additional connecting block between two programmed blocks. It also performs the anti-collision monitoring at top and at bottom.

Due to the orientation the jet section is no more a circle but an ellipse. The system will automatically adjust the value to compensate correctly. This function requires the option FPSO000154 Rotation Tool Center Point (G26 RTCP).

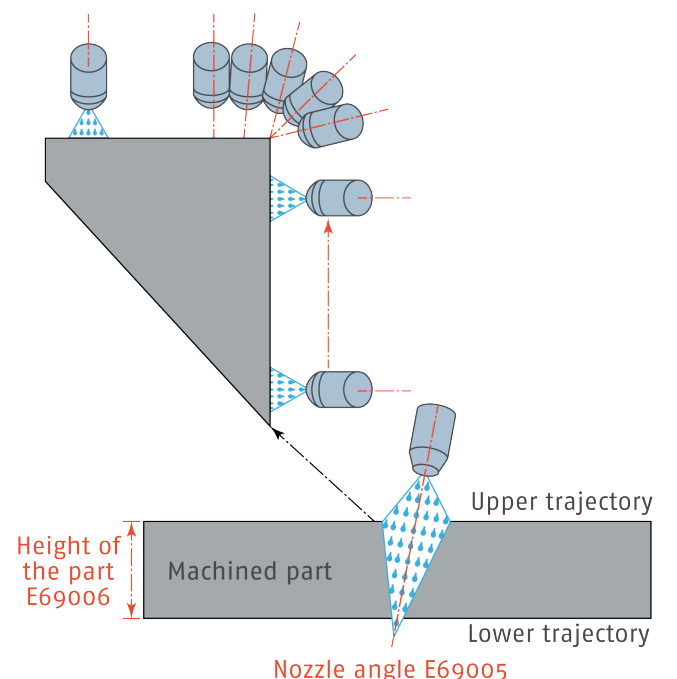

#### FPSO000914 Inclined plane machining

The inclined-plane machining function manages many different machine head structures and simplifies programming of the machining operations.

Rotation and translation are combined to define a three-axis reference system with any orientation, used by the CNC to control the machine.

All the standard functions can still be used in this condition:

- L and R tool offsets,
- Canned cycles as well as control of speed and feed,
- Acceleration and travel

The inclined reference system is defined as follows:

- UVW / XYZ translations
- ABC rotations around each of the XYZ axes

All five-axis machine structures are supported with their offsets:

- Machine-head with two rotary axes with or without angle
- Machine-head with one rotary axis and turntable with one rotary axis
- Turntable with two rotary axes

The inclined plane machining function is parameterized using FlexiumPro Tools. The installation program generates a macro containing a description of the machine's kinematics.

#### Workpiece positioning compensation (3DWPC)

When a workpiece is positioned on a machine it might be very difficult to align it perfectly due to its weight, its structure, a previous machining operation or for some other reason. A shift parallel to the main axes is not a problem and merely requires a work offset to adjust it. However, a tilt can become quite tricky because it implies compensation of the tool orientation. One common solution, after identifying the offsets and tilt angles, is to reprocess the program and generate a new one to take the misalignment into account, but this obviously takes some time. NUM offers some cycles and parameters to align the workpiece or compensate easily without requiring the regeneration of the part program, and the operator can double check their settings using a dedicated page inside the HMI. The advantage is that the part program will not be changed because the CNC will compensate for the misalignment automatically.

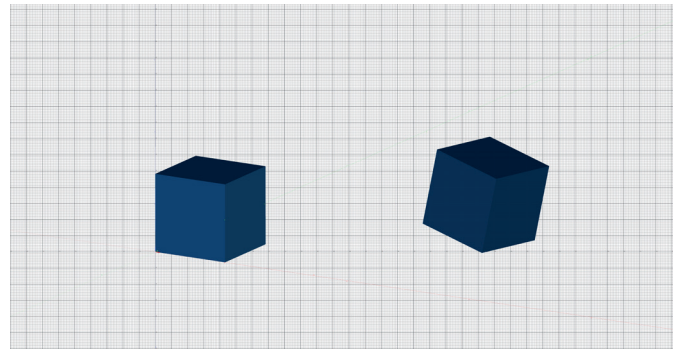

#### Tool vector programming

With the workpiece positioning compensation, we introduced the concept of tool vector. This approach can be used also for a generation of part program independently from the machine. The part program written with a tool vector orientation can run on machines with different kinematics. In fact, a CNC that knows the machine's kinematic can compute the angles of physical rotary axes and the linked linear transformation. The advantage is that a part program can be generated without knowledge of the machine's kinematic where it will be executed.

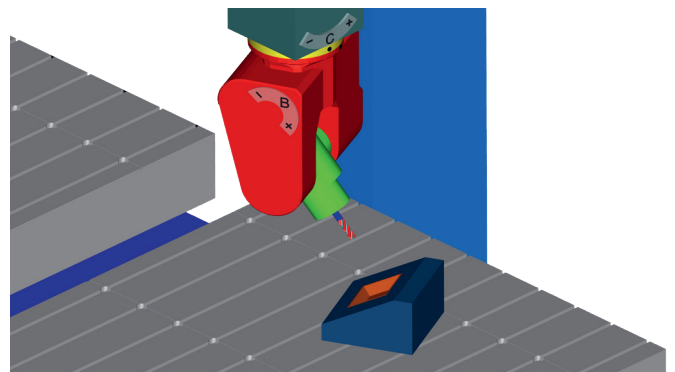

#### **FPSO000681      NUMgrind GC Cycles**

The cylindrical grinding package includes OD/ID grinding cycles for 2-axis (X/Z) horizontal or vertical grinding machines and inclined axis capability. The dressing station can be table-mounted or rear-positioned to accommodate a range of machines. Standard forms or profiled wheels can be dressed with single point, double point or roller dresser.

The packages include the following features:

Grinding Cycles:

- OD/ID Plunge / Multi-plunge
- OD/ID Plunge with inclined Axes (Angular Plunge)
- OD/ID Oscillating Plunge / Multi-plunge
- OD/ID Cylindrical Traverse
- OD/ID Profile Grinding
- OD/ID Conical Traverse
- OD/ID Oscillating Shoulder / Shoulder Plunge
- OD/ID Shoulder Traverse
- OD/ID Shoulder with fillet

Auxiliary Grinding Functions:

- Wheel speed calculation
- Z position probe
- Manual measurement
- Taper correction
- Fixed or roller dresser wheel dressing
- Fixed dresser wheel shaping
- Part, Dresser and Z Position Probe Setup Routines
- Full cycle support for In-Process Gauging and Gap Elimination (AE Sensor)

#### **FPSO000682      NUMgrind Cylindrical + Non-Circular Grinding Cycles**

The non-circular grinding package is designed for a 3-axis (X/Z/C) horizontal or vertical grinding machine. The package includes all the functionalities of FPSO000681 (NUMgrind GC cycles) and the possibility to grind geometries in the Cartesian or polar coordinate system.

The NCG cycles have a wide range of parameterization possibilities. Furthermore, an error compensation cycle can be used to compensate for form errors, which can occur due to workpiece deflection, for example, without any problems.

Additional cycles, which are included in the package, are as follows:

- OD/ID Non-Circular Grinding
- Error Compensation
- Axis-Spindle Switching

#### **FPSO000595      Fast Gear Alignment (FGA)**

Gear Alignment allows for the exact positioning of pre-cut gears to a previously recorded master gear position. It enables processing gears without manual intervention. FGA is ideal for automated mass production of gears.

Using a sensor (hall, inductive, etc.), you record rising and falling flanks of a master gear manually aligned with the tool.

Recorded values will then be used to subsequently automatically align following gears to exactly the same position as the master gear with regard to the tool. Second stage hobbing or skiving, TWG, or profile grinding can start instantly.

The interface is a simple call of G184 code for the master gear and G186 for the following gear without any parameter. The FGA will take care of the positioning of the following gear.



#### **FPSO000690      NUMgear Hobbing Cycles**

The NUMgear Hobbing cycles provide single indexing and continuous hobbing. Hobbing requires the MLEGB (FPSO000699). FGA (FPSO000595) is optional.

The cycles provide the following functions:

- Single indexing - milling
- Continuous Cutting
- Axial Cycles
- Crowning with optional offset or straight sections
- Up to 3 taper sections that can be combined with crowning
- Selectable dwell after radial and axial infeed
- Radial Cycles
- Worm gear with optional tangential feed
- Single indexing
- Diagonal Cycles (combine axial and radial)
- Cut helical, spur or spline gears
- Taper root splines
- Up to five gears on one work piece using different hobs on one axis
- Tailstock control
- Coolant control

#### **FPSO000691      NUMgear TWG Cycles**

NUMgear TWG (Threaded Wheel Grinding) cycles provide both grinding cycle and dressing cycle. Both cycles can run independently. Both cycles require the NUM MLEGB (FPSO000699). FGA (FPSO000595) is optional but recommended. TWG Dressing is based on a full-form dressing wheel.

The cycles provide the following functions:

- Grinding
- Free form flank shape point interpolation
- Automatic grinding wheel shift
- Two way grinding
- Pass input automated and manually
- Shifting options per cut
- Dressing after a predefined number of grinding cycles
- Dressing
- Roughing and finishing
- Feeds and passes
- Tailstock control
- Coolant control

#### **FPSO000692      NUMgear Shaping Cycles**

The NUMgear Shaping cycles provide for internal and external gear shaping. Shaping requires the MLEGB (FPSO000699). FGA (FPSO000595) is optional.

The MLEGB controls both the shaping movement and the turning of tool and gear.

The cycles provide the following functions:

- Tailstock control
- Coolant control

## Programming Functions

### Standard Programming Functions

#### ISO Code:

FlexiumPro complies with the ISO standard and includes specific extensions for advanced functions.

The general programming format is as below:

%.....	
N.....	Sequence number
G...	Preparatory functions
XYZ+8.8	Axis movements
UVW+8.8	Auxiliary axis movements
ABC+5.8	Rotary axis movements
IJK+5.8	Circle center coordinates
EA3.3	Taper angle
EB5.8	Fillet or chamfer
EC3.8	Indexed spindle axis
ED3.8	Programmed angular offset
R8.8	Circle radius
F....	Feed rate
M...	Miscellaneous functions
S.....	Spindle speed
T.....	Tool number
D...	Tool offset
L...	Program variable
E.....	E parameter
H....	Subroutine number
/	Block skip

#### Datum Shifts

Regardless of the programming mode selected, the system always processes the dimensions with respect to a zero point or origin. The system provides 5 sets of DAT1 (part origin setting) combined with up to 99 DAT2 (program origin setting).

#### Measurement Origin (OM)

The measurement origin is a suitable point defined on each axis which sets the absolute measurement origin or zero point. The coordinates of this point can be entered or modified in special machine parameters.

#### Part Origin (Op)

The part or workpiece origin is independent of the measurement system. It is defined with respect to a suitable setting point on the workpiece. The part origin is specified with respect to the measurement origin by datum shift DAT1.

#### Program Origin (OP)

The program origin defines the origin of the program coordinate system. It is independent of the measurement system and is specified with respect to the part origin by datum shift DAT2.

FlexiumPro provides 4 Part origins and up to 99 program origins selectable by G code.

#### Subroutines

Subroutines are special programs called by the main program. They are created by the OEM, by NUM (in the case of macros) or by the user to simplify and optimize the main program.

Example: Pattern repetition in several locations.

Subroutines can be called by the specific function G77. They can also be called by the PLC or by an M function.





#### **Parametric Programming**

Parametric programming simplifies the writing of programs and the creation of identical families.

There are two kinds of parameters: L variables and E parameters.

L variables and external E parameters can be assigned to all the program addresses. Operations available on parameters:

- Addition, subtraction, multiplication, division, square root, truncation, sine, cosine, arc tangent
- Conditional and unconditional branches (>, <, =), logic
- AND and OR

#### **Profile Geometric Programming**

This special ISO programming language allows the rapid development of parts with a complex geometry consisting of a sequence of linear and circular geometric elements.

Main Functions:

- Insertion of fillets and chamfers
- Multiple line definitions
- Multiple circle definitions
- Ability to implicitly declare from one to three consecutive elements and have the system compute the intersection or tangent points

#### **Customized Cycles**

It is possible to create additional cycles that are specific to an application or a machine. These cycles are then called by new G or M functions. For G functions, it is possible to create programs %10100 to 10255 and call them by functions G100 to G255 respectively. For unassigned M functions, a machine parameter, 'subroutine call by M function' is used to call a program number defined at installation when the M function is detected in the part program.

#### **Inch/Metric**

Internally, the system works in metric units. Display and programming default units for dimensions can be selected by a machine parameter when integrating the system. This default can be overwritten by the HMI, using function G70 for programming in inches, and function G71 for programming in metric units.



## Optional Programming Functions

---

### **FPSO000506      Scaling factor (G74)**

The scaling factor can be entered from the keyboard or via an E parameter to modify the dimensions of the part to be machined. It is expressed in thousandths of the programmed dimensions. The variations are between 0.001 and 9.999.

### **FPSO000507      Angular program offset (ED)**

Function ED is assigned a value which defines an angular rotation with respect to the program origin. The angular offset affects the axes programmed in the blocks following the function. Example of application: machining along a circular pattern.

### **FPSO000511      File handling in NC memory (G76)**

This function is used to save the values of several parameters in a file included in a subroutine or a block sequence of the main program. The nominated file lists the L variables and E parameters that will be updated with current settings.

Syntax:

- G76 Transfers the current settings of L variables and E parameters to the specified program
- H Specifies the program to which the settings are to be transferred
- N..N.. Specifies the block sequence to which the settings are to be transferred

### **FPSO000520      On the fly measurement / probing (G10)**

The Flexium RTK provides four probing inputs. Application of a signal to either one will cause the actual positions of the axes to be stored in registers, and if programmed to do so, can trigger an interruption of the move.

### **FPSO000535      Structured and symbolic programming**

Structured programming based on symbolic variables makes programs easier to read and understand. Symbolic variables (1 to 32 characters) can be created and assigned to all ISO functions and used in parametric expressions. In addition a stack is available to preserve such variables as well as the L variables.

### **FPSO000536      Building a profile table**

This high-level programming function is used to create a table and to store into it the data concerning a contour. The data in the table can then be accessed in any order, used by structured programming, and optionally modified and then executed. Typical applications are contour transformation (particular tool compensation), backwards execution etc...

The contour table has the capability to store additional fields for general purpose, feed rate, spindle speed etc.

### **FPSO000465      Advanced contour offset (C.OFF)**

Advanced contour offset is a function which processes user defined contour in order to offset them by a given value. The contours can be programmed in both Cartesian and polar coordinates. The contour offset can be constant or variable along the contour path. In this mode, initial offset and final offset are programmed and the final offset is reached at contour end.

Offset contour can be joined together to allow spiral approach to the final path dimension. This function could also be used for pocket milling. The contours can be either internal or external to the workpiece. During contour offset function the contour curves are analyzed to allow constant contact tool-piece feed rate. C.OFF can also shift a contour on the laying plane and compensate the misalignment between workpiece center and tool axis (for polar contour only).



#### FPSO000500 Early Block Change (G777 EBC)

Early Block Change EBC means a faster machining cycle, as the NCK can begin the execution of the next block before the previous has been finished. EBC also provides a very fast signal exchange between PLC and part program, which allows the PLC to send and receive information about the program execution using 32 dedicated input bits and 32 dedicated output bits.

The block change may occur under several conditions:

1. Immediately, the two blocks are therefore executed simultaneously
2. After a certain distance has been traversed
3. When the residual distance (Delta or To Go distance) is lower than a value
4. When the PLC sets a certain signal
5. When the block is normally ended (standard way)

Furthermore the NCK communicates to the PLC when certain conditions in the program execution have been reached, allowing the PLC to start auxiliary operations without the need to program M functions and thus without stopping any axes.



All these features are easily programmed with a single G function and a few parameters. For example, “Z100 G777 Q1 X40 P24 I25” tells the control to move the Z axes to the position Z100 mm, when 40 mm have been travelled the PLC output bit 24 will be set, and when the PLC input bit 25 is set then the execution of the next block will start, even before the Z axis has arrived at its final position.

Simple example in the chart:

```
G777+ Q1 D80  
G1 X100  
G1 Y100 Z100
```

#### FPSO000250 Dynamic operators

This powerful language opens the real-time kernel of the CNC.

It uses simple operations to perform real-time computations which can act directly on the axis position references and on discrete or analog inputs and outputs. This tool, which also supports exchanges with the PLC program, offers the possibility of immediate correction according to the environment. The dynamic operators operate with high priority at the real-time clock frequency of the CNC and do not penalize the functions managed by the CNC software. They are very useful in application programs, especially for operations on the servo systems and other high-speed tasks.



## Tool Functions

### Standard Tool Functions

#### Tool Axis Selection (G16)

Tool Axis Orientation Function G16 with one of the mandatory arguments (P, Q, and R) followed by a plus or minus sign defines the tool axis orientation.

The tool axis can be oriented in six different positions on machines with an interchangeable tool-head. This allows the tool axis to be defined independently of the interpolation plane.

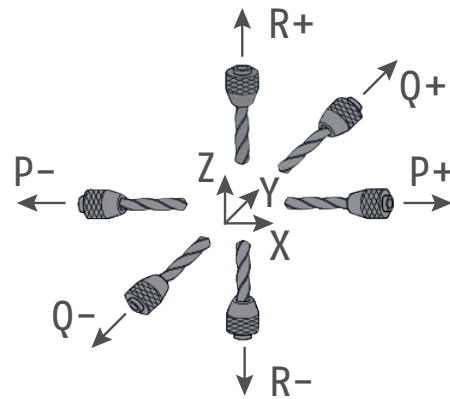

2

#### Tools Offset

**Turning Tools:** The tool length offset is assigned to the tool axis orientation defined by G16. The programmed tool paths are corrected by a value equal to the tool length X and Z defined in the D offset selected.

**Tool Radius Offset:** the programmed tool paths are corrected by a value equal to the tool insert radius based on the tool nose orientation defined by codes C0 to C8 defined in the D offset selected.

- G41 offsets the contour to the left with respect to the direction of movement
- G42 offsets the contour to the right with respect to the direction of movement

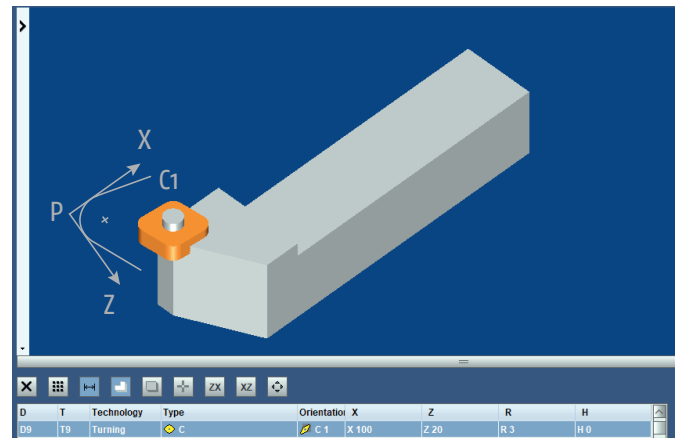

#### Milling Tools

The tool length offset is assigned to the tool axis orientation defined by G16. The programmed tool paths are corrected by a value equal to the tool length L defined in the D offset selected.

**Tool Radius Offset:** the programmed tool paths are corrected by a value equal to the tool radius defined in the D offset selected.

- G41 offsets the contour to the left with respect to the direction of movement
- G42 offsets the contour to the right with respect to the direction of movement

#### Tool Wear Compensation

It is possible to compensate for slight variations of the tool dimensions. These compensations are taken into account immediately when below a certain amount. They can be entered automatically by the PLC or by the operator (in such case they are incremental).



## Optional Tool Management Functions

### FPSO000401 Extension to 255 offsets

The basic system includes 32 tool offsets for turning systems, and 99 for milling.

The D address followed by a number selects the tool offset.

The tool dimensions are stored in tables and validated according to the programmed axes.

### FPSO000400 3D tool radius correction (G29)

With 3D tool radius correction, the tool axis is parallel to one of the axes of the basic three-axis reference system defined by the tool axis orientation function (G16). Each programmed point is associated with a vector normal to the surface to be machined, defined by its P, Q and R components.

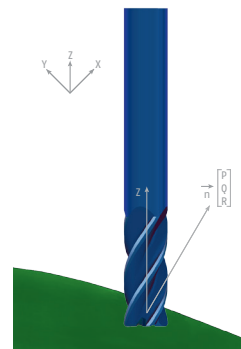

### FPSO000411 3D tool radius correction in RTCP (G43)

With 5-axis tool offset, the tool axis can be inclined on machines equipped with a double twist tool head.

Each programmed point is associated with a vector normal to the surface to be machined, defined by components P, Q and R, plus a tool orientation vector defined by components I, J and K, where applicable, which define the angles of the twist head.

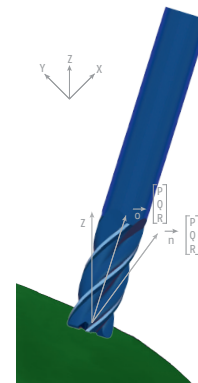



## Optional Machine Operations

---

### **FPSO000082**      **N/M Auto**

When enabled by the PLC, this function allows the operator to manually control up to five axes while the other axes remain under control of the part program.

The axes which can be controlled manually are selected and deselected by E parameters in the part program.

Any command in the program for movement on these axes is then ignored. Only the manual controls are active.

If this function is used to mode the milling head axes then RCTP will probably be required.

### **FPSO000505**      **Emergency retract (G75)**

On receipt of a signal sent to the PLC the current block is immediately interrupted and a jump to a previously specified program sequence is executed.

This feature is widely used on grinding and gear cutting machines.

Emergency retract can also be triggered automatically in some predefined conditions (refer to commissioning manual).

### **FPSO000523**      **Backtrack along stored path**

This function is used to backtrack the axes and then return it to the point where the program was interrupted all being made under the operator's control.

On a feed stop command, the operator enables the backtrack-along-path command. As long as the command is active, the axes are moved back along the path at the feed rate programmed in the previously executed and memorized (up to 100). This function is operative in automatic, single-step and dry run modes.

When the operator enables the return command to resume, the trajectory is then executed forward up to the point of interruption, where the initial mode will be restored.

The program can be resumed beyond of the backtrack point.

Tool offsets and wear offsets less than 0.1 mm can be applied during backtrack and return.

The automatic axis recall function can be used in intervention mode. In this case, the points on the manual backtrack path are stored (maximum 10 points) and restored in the same order in the axis recall phase at the traverse, up to a programmable distance from the restart point.



## Standard Compensations

### Axis Calibration

This function corrects the axis position according to the defects of the screw, rack or scale of the same axis.

### Interaxes Calibration

This function corrects the position reference of an axis via the position of another axis. The data are entered in a table. A typical use of this function is to compensate for the weight of the “ram head” on a milling machine.

## Optional Compensations

### FPSO000460 VECComp rotary axes

On a rotary axis, even a little imperfection can have a large influence due to the lever effect. To compensate the resulting errors at the Tool Center Point without a complex measurement campaign, VECComp Rotary is the right solution.

A rotary axis is defined by its average line of rotation that, in respect to the machine referential, presents the following characteristics:

- Off centering
- Axial position error
- Two tilt angles

Example is shown for a C axis.

Each of these errors is defined by the normalization (Suffix C defines the axis):

- EX0C: Position error in the X direction
- EY0C: Position error in the Y direction
- EA0C: Perpendicularity error relative to Y
- EB0C: Perpendicularity relative to X
- EC0C: Zero position error

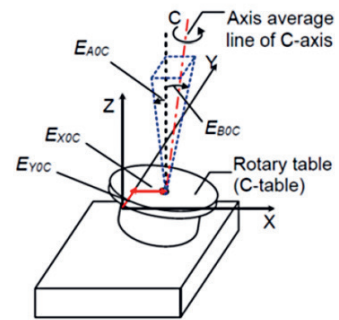

After measurement of the rotary axis imperfections, the errors will be entered in a table of data with the help of a worksheet macro. The error compensation is performed after defining a model of the machine structure which is considered as a succession of elements. Considering this model and based on the above values of errors, VECComp Rotary will calculate in real time the compensation to apply in order to position the Tool Center Point with the maximum accuracy.

The activation of the compensation only consists into the programming of a G code and no more than three parameters at the maximum. The possibilities of a temporary suspend and resume of the compensation is provided.

VECComp rotary is compatible with the following five axes machines:

- Tilting turntable or trunnion machines (A)
- Swivel head and rotary table combined (B)
- Dual twist head machines (C)

Conventional 4 axes machine with either one turntable or one swiveling axis head are compatible as well.

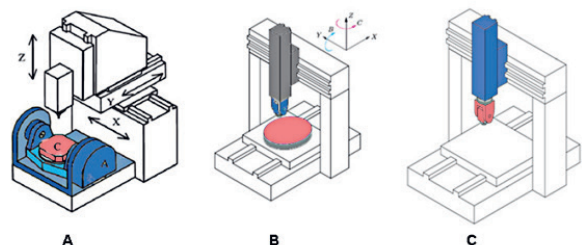

### FPSO000458 VECComp 3-/4-axes Machines

### FPSO000459 VECComp 5-axes Machines

VECComp system is a function of FlexiumPro NCK, based on geometric error compensation, to enhance machine tool volumetric accuracy and work piece precision. The errors of machine tools come from imperfect geometry and dimensions of machine components, axis alignment errors, error motions of linear or rotary axes, thermal deformation, dynamic and structural deformation of the machine under load.

VECComp system is a real time application of spatial error compensation based on kinematic error modeling.

For each machine having a serial kinematic structure, the error model is originally designed as a superposition of error motions of linear or rotary mechanical components starting from the work piece side to the cutting tool center. A library of kinematic error machine models is managed by the embedded VECComp, including from 3 axes configurations up to 5 axes machine in gantry configuration.

The purpose of such control is minimizing the spatial error of tool center position at an arbitrary point in the work piece. Each geometric error has been previously measured by a laser interferometer or by other metrology optical devices.

## Optional Measuring Functions

### FPSO100590 Probing cycles for turning

These cycles are designed for use in adjustment and measurement applications generated manually or automatically. They include the following functions:

- Probe calibration
- Tool presetting
- Workpiece measurement and offset adjustment
- Determination and restoring of DAT2 on the linear X and Z axes

All these cycles can be edited.

### FPSO100591 Probing cycles for milling

The available cycles are designed for use in setting and measurement applications generated manually or automatically. They include the following functions:

- Probe calibration
- Tool presetting (L, R)
- Determination and restoring of DAT2 on the X, Y and Z axes (workpiece location)
- DAT2 on the A, B and C rotary axes (workpiece alignment on a table)
- Determination and restoring of DAT3 (off-centering of a workpiece on a table)

All these cycles can be edited.

### FPSO000153 Kinematic measurement cycle

The Kinematic measurement cycle (G248) is intended to measure and then compensate the geometric deviations of a rotary head. It can be used during machine commissioning or after a machine crash.

It requires:

- a digital touch probe
- a calibrated ball

The principle is to execute different measurements taken at strategic points chosen by the macro itself. The results of those measures are then computed by the macro in order to fine tune the head dimensions. The head description parameters are automatically optimized.

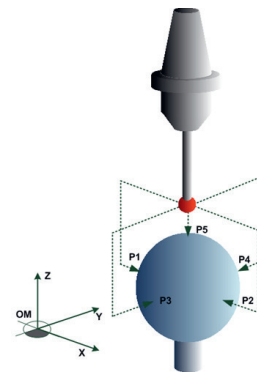





## Standard HMI Functions

---

The FlexiumPro HMI is a modular HMI with a fresh new design, optimized for touch operation and shop floor visibility. Thanks to its modern software architecture, the FlexiumPro HMI is fully customizable.

Pre-defined front-end and background components are available to be positioned and combined in different context pages.

The customer has the ability to create components with their own requirements and include them where they are needed while existing ones can be replaced.

These plug-ins can include background services such as a job manager, data logging, and front-end modules for the operator to use a specified workflow.

FlexiumPro HMI has 7 contexts, each of which displays all the necessary information. The different contexts are:

- PRODUCTION: Actual machining data, Program in progress
- PROGRAMMING: Part program management and editing
- TOOLS: Managing tool dimensions and wear
- WORKOFFSET: Manage origins
- VARIABLES: Display of programming (L., E..) parameters as well as symbolic variables and PLC variables
- DIAGNOSTIC: View detailed error messages and information about the machine
- SETTINGS: Protected context for HMI setup and some machine diagnostic
- sF9: Additional empty context for customization

FlexiumPro HMI includes the basic version of Flexium 3D described below.

### Languages

The FlexiumPro HMI is a multi-language human-machine interface designed to offer a comfortable user experience. Users can select any of fifteen different languages:

- |                       |                         |
|-----------------------|-------------------------|
| 1. French             | 9. Polish               |
| 2. English            | 10. Russian             |
| 3. German             | 11. Turkish             |
| 4. Italian            | 12. Hungarian           |
| 5. Chinese Simplified | 13. Romanian            |
| 6. Portuguese         | 14. Chinese Traditional |
| 7. Spanish            | 15. Danish              |
| 8. Czech              |                         |



## PLC Visualization

---

FlexiumPro offers the possibility to create custom screens controlled directly by the PLC application. This is useful for diagnostic or maintenance purpose as well as supervision.

These versions are available:

### **FPSW282502      Remote Target Visualisation**

The Remote Target Visualization contains a PLC Visualization on a Windows PC system. It shows a full screen or sizable image running independently of FlexiumPro HMI

### **FPSW282503      Web Visualization**

This brings the possibility to display a full custom visualization via a web interface (browser).



## Standard Flexium 3D Functions

---

Flexium 3D is a 3D graphical simulation software for part programs written in ISO-Code (DIN 66025 with NUM dialect), which exists in different versions for milling, drilling and/or turning applications as well as water jet and plasma cutting.

During the part program simulation the path of the TCP (tool center point) is visualized, the material removal on the work piece is simulated and a collision check is made between machine components, part and tools.

Operating the software is oriented on mouse and keyboard usage as well as single and dual touch gestures.

Flexium 3D takes as input the machine configuration (e.g. machine parameter, kinematics and physical parts, tool library, blank and collet definition), offset table and the NC program (part program).

An ISO-parser is integrated inside the host application (simulation), which analyzes the part program, makes all tool length and tool radius compensations as well as offset transitions and rotations, and substitutes mill-, drill- and turning cycle definitions with real movements.

The wired path simulation is standard. According to the type of machine (T or M), optionally mixed configurations, material removal as well as collision checking are available.

Two versions are available:

- Office version: used as a standalone program preferred in production planning without CNC (Dongle is needed)
- Machine version: integrated in the FlexiumPro HMI for pre-simulation or in online synchronization to the machining

## Optional Flexium 3D Functions

---

### **FPHE557200 Flexium PC Dongle**

The dongle is required to run Flexium 3D and Flexium Office outside a FlexiumPro system.

### **FPSW282150 Simulation for Turning**

The base system should be ordered as a turning or milling system.

### **FPSW282151 Simulation for Milling**

The base system should be ordered as a turning or milling system.

### **FPSW282152 Simulation Mixed T & M**

Once the base system is chosen, this option gives the possibility for simulation of both turning and milling.

### **FPSW282153 Simulation with Material Removal**

The base system displays the tool path. This option also allows the blank part and material removal to be displayed during the process.

### **FPSW282154 Simulation with Collision Detection**

This feature shows possible collisions during simulation. The software will show the number of collisions, their location on the part (with a red box) and in the part program (blocks highlighted in red). During setup it is possible to select which kind of collision should be detected. In order to work safely, this option will require the machine to be accurately described.

### **FPSW282155 Online Simulation**

This function is available on the machine version. It allows the simulation to be synchronized to the actual movements of the axes, to show the process in real-time.



#### FPSW282158 Flexium 3D – Path Editor

This optional 3D-Path Editor is released only for all FlexiumPro platforms and allows a graphical/text supported path optimization/reworking of digitized or CAD/CAM generated part programs in 6 axes. Principle of the mode is a very fast visualization of the programmed ISO trajectory in program frame for the most interpolation commands (except polynomial interpolation) without using the PcParser-tool. It can be also used as a simple part program editor with simultaneous graphical path display.

1. 3D-Path View: visualization of the complete trajectory of the part program (PP) in default plane view (G17). The white cross highlights the current PP line
2. 3D-Text View: the text window of the selected part program with syntax highlighting, dynamic edit command box, command line editor for adding/deleting lines, 'multi-line edit' and visualization of the current PP line
3. Plane selection and helpful operation controls
4. Parameter/value edit box with slider controls
5. Complete file handling controls
6. Complete file handling controls
7. Progress bar

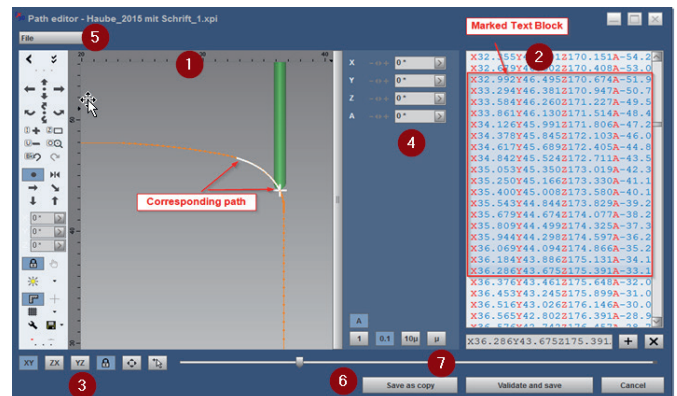

#### FPSW282157 Flexium 3D SEARCH Mode

The present SEARCH Mode for FlexiumPro has been extended with a graphical supported method inside Flexium 3D. The same operating philosophies are valid for HMI with the SEARCH Mode initiating from Flexium 3D.

Targets and customer benefits are:

- Integration of a graphical extended SEARCH Mode in Flexium 3D and NCK firmware
- Preview of loaded part program with fast offline simulation of TCP path
- Definition of re-engage position (also within a NC block) with mouse or touch operation
- Specification of different and flexible approach strategies depending on the application
- Execution of a sub-program with programmed movements, machine functions and other NUM ISO-dialect in re-engage process

To use graphical supported SEARCH Mode on FlexiumPro systems the HMI option Flexium 3D Online-simulation (FPSW282155) is required.

Variants:

From this geometrical consideration three variants for the approach path to the TCP trajectory are possible (references are the red approach contours):

- Direct vertical approach to TCP trajectory
- Tangential approach with circular element
- Tangential approach with circular and linear element

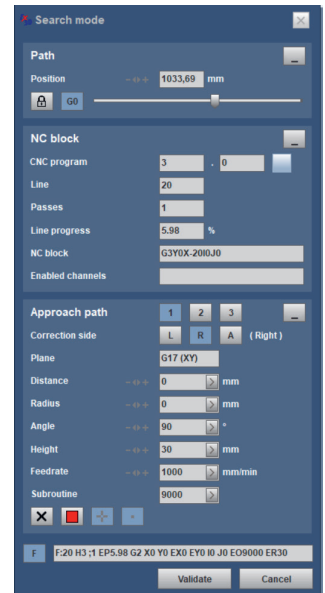
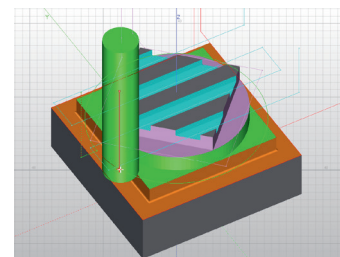
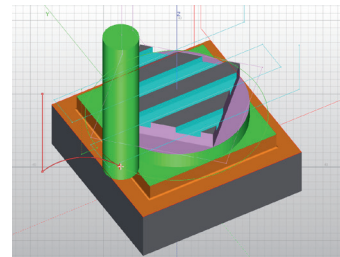
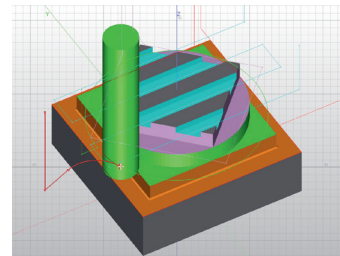



#### FPSO000521 Online Collision Detection with Flexium 3D

##### Collision calculation in general

Since its initial release more than 10 years ago, the Offline collision detection remains an integral element of NUM's Flexium 3D Simulation software. A significant advantage and competitive differentiator of NUM's collision detection, is the consideration of the actual blank dimension and the removed material during collision calculation. Not only does Flexium 3D consider the tool path, it also includes the tool dimension, tool orientation, tool holder and all other machine components simultaneously to prevent collision.

##### Enhancement to Online collision detection using Flexium 3D for manual Move

As machining processes become more and more sophisticated, the risk of collisions between the tool, workpiece and machine components increases. Collisions mean costly downtime and cause expensive damage to the workpiece, spindles and sometimes even the whole machine.

Flexium 3D features together with NCK extensions form new functions which allow monitoring and preventing online collisions during manual/handwheel jog or in Search-mode (part program resume) and in commissioning phase. To reach this target axes dependant collision free limits are calculated and transferred to NCK before the axis move is released.

Even in critical 5-axes machining cases including complex blank shapes, active RTCP or Tilted plane transformation, manual motion online collision detection, makes operation simpler and safer!

Collision detection highlights:

- Possibility to configure safe distances for different machine components (tool, blank, collet and machine parts) individually
- Status synchronization of Online Collision detection for Flexium HMI and Flexium 3D
- Graphical supported visualization of collision components
- Operator messages indicate the axis and direction of collision
- Prevention of movements in the collision state
- Multi axes motion of RTCP/Tilted plane are supported



HOME	CNC2	SY SW	EXPErr	COLDET	FDHLD
MAN	1000	DRIP	INTER	NFD'S	MACKNW
	M01	/	mm	VALID	PLC
START	STOP	M02	COMM	CNC 0	CH 1

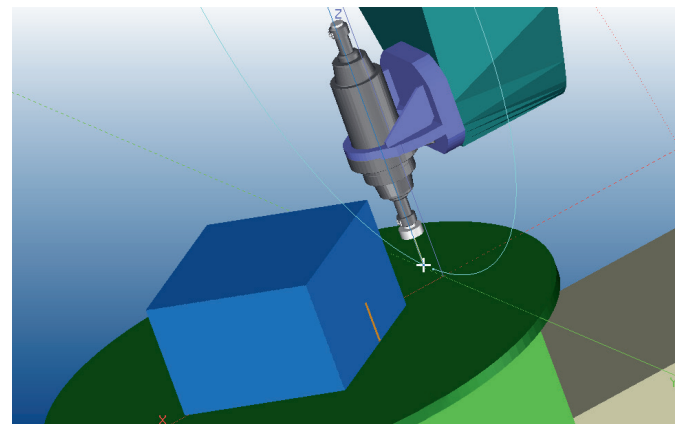



## FlexiumPro Tools Standard Functions

---

FlexiumPro Tools is part of the Flexium Suite and includes all functions needed for the integration and commissioning of the machines. FlexiumPro Tools allows users to program, configure and optimise system components within a unique environment:

- PLC
- CNC
- Servo drives and motors
- Sensors
- EtherCAT and CANopen gateways with a comprehensive set of I/O and logic terminals

### Easy Operation

The menu structure of FlexiumPro Tools provides a perfect overview of the entire system. Navigation inside the device tree is simple and clear, allowing easy access to all functions for quick change of settings.

### Project Handling

Access rights can be defined for different users. Each project consists of one single file to ensure easy handling and to prevent data losses. New equipment or versions are quickly integrated using EDS for CANopen devices and Device Descriptions (DevDesc) for NUM devices. Libraries can be used in different versions and can be compiled to protect know-how. Complete projects, including libraries, devices and the source code can be archived, thus making restoration possible at any time in the future.

### PLC System Programming

The PLC of the Flexium system is programmed in accordance with IEC 61131-3 and allowed different graphical supported programming environments. For more details see next pages.

### FlexiumPro RTK (CNC) Parameterising

Dedicated editors for options, programming, memory, channels, axes (with individual windows for settings, coupling, kinematics, travels, servo system, HSC) miscellaneous hand wheels, axes calibration and more ensure easy handling and the best overview during editing.

### Servo Drives Parameterising

All servo drives of the Flexium system can be found and accessed easily in the menu structure of FlexiumPro Tools. For better overview, the structure is displayed in the way the system is set up, e.g. servo drives are listed under the Flexium NCK.



### Field Buses

Theoretically, any CANopen and/or EtherCAT compatible device can be connected to the bus using the EDS/ESI/XML file supplied with the device. NUM provides a comprehensive range of most common I/O components based on EtherCAT technology (EtherCAT = Ethernet for Control Automation Technology). It is the real-time Ethernet technology standardized by EtherCAT Technology Group.

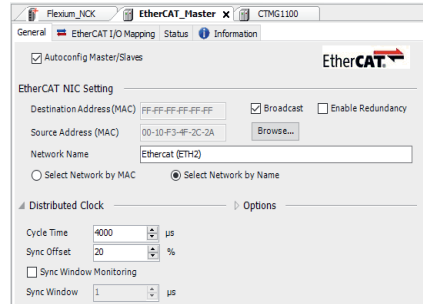

NUM provides machine panels, drives for auxiliary axes and other devices that, by means of dedicated windows and libraries, can be easily integrated as field bus devices (EtherCAT or CANopen).

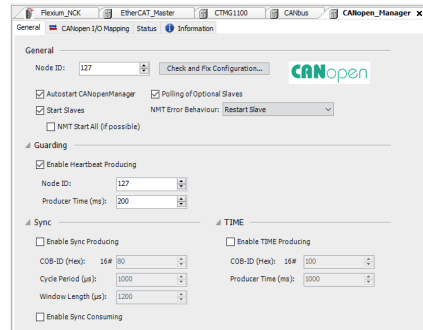

### Instruments

For easy commissioning, a huge set of instrument tools are available in FlexiumPro Tools.

### Oscilloscope

The oscilloscope tool is used to set up the recording and to display drive internally measuring point data. Up to 4 channels of any measure point can be recorded in sampling frequencies up to 20 kHz. Triggers can be used for recording issues, such as drive alarms, threshold values of any measuring point or stimulus functions. The stimulus function can be used furthermore for tuning and testing purposes. The integrated graphics can display up to 4 different measurements for comparison purposes. To analyze the recorded data, cursor functions are available as well as storing and loading of recorded data. Further information on how to use the recorded data for tuning purposes can be found in the Manual.

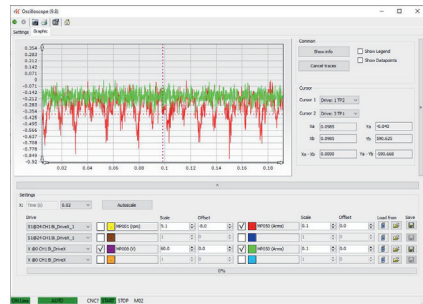





### Test Points

Within the FlexiumPro Tools instruments exists also a displaying page of up to 8 drive test points. The display can be used to show current measure point data as well as buffering their minimum and maximum value. With up to 8 simultaneously displayed measure points the data from 2 drives with all 4 measure points or 8 axes with only 1 measure point can be displayed at the same time.

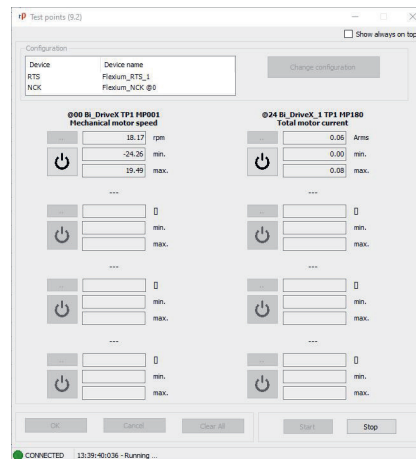



## PLC Programming

---

The logical and easily manageable development environment offers dedicated tools for development, commissioning and maintenance. The PLC program structure is displayed in a logical structure showing the different blocks and folders. The program editors can be opened in the following languages:

- Instruction List (IL)
- Ladder (LD)
- Function Block Diagram (FBD)
- Structured Text (ST)
- Sequential Function Control (SFC)

The PLC provides libraries for system functions, customer functions and its own programming functions.

Task management is very comfortable and can be cyclic, event-controlled or freewheeling.

Data and variables are based on a high level language such as C. Data types can also be user defined.

The program can be easily structured using program building blocks, functions and function blocks with entities.

Object oriented programming is also supported and allows safe programs using objects, methods, properties, actions, interfaces and inherit functions.

## Optional Functions

---

There is no option required to develop any case of FlexiumPro application.



## FlexiumPro CNC and PLC Exchanges

---

Communication between CNC and PLC is extremely fast since a shared memory is used, data like these are exchanged (not exhaustive example):

### General Read Data

- Current modes, JOG increments, CNC error number, CNC active, E parameters
- CNC and machine status
- Active program number
- Axes data (initialized, moving, clamped, axis state)
- Spindles (status, speed)

### Channel Specific Read data

- Channel states, G functions, current modes
- Encoded M functions without acknowledgement, on-the-fly
- Encoded M functions with acknowledgement
- 34 decoded M functions
- Tool number

### General Write Data

- Control of axis jogs, mode control, error messages
- Selection of channels, program numbers
- Processing of spindles, potentiometers, commands, set points
- Inhibiting of certain modes, jog commands, feed rates
- Torque and reference enable for digital axes
- E parameters

### Channel Specific Write Data

- Machine functions
- Axis feed-rate override potentiometer for all channels

## FlexiumPro PLC/Machine Exchanges

---

FlexiumPro PLC communicates with the machine via a field bus, CANopen or EtherCAT. EtherCAT is standard for all FlexiumPro configurations, CANopen is standard for FlexiumPro 68 and optional for FlexiumPro 6 and FlexiumPro 8.



## FlexiumPro PLC Optional Functions

---

### **FPSW282124**      **Extended NCK Access**

This function provides the option of accessing NC Data which are not exchanged cyclically (e.g. current axes' positions, machine parameters, all E parameters, ...) as well as providing access to the part program memory for uploading, downloading, memory available, directory.

### **FPSW282305**      **EtherCAT Safe PLC**

The TÜV certified option allows to extend a project with an EtherCAT controller for the development of safety functions with TÜV certified safety logic modules (e.g. CTMP6900, CTMP1960-2600) and digital FSoE I/O modules (e.g. CTMS1904, CTMS2904, CTMS2912) in the EtherCAT network. The extension with safety-specific editors and configurators is integrated seamlessly into FlexiumPro Tools. It enables cost effective and scalable realization of simple safety applications with zero sytem integration or adaptation effort and low acceptance expenditure.

### **FPSW282312**      **EtherCAT IO-Link Master for CTMT6224**

License option needed for the EtherCAT IO-Link Master terminal (CTMT6224).

### **FPSO000430**      **CANopen Interface**

Connection and license for CANopen bus. This feature is standard on FlexiumPro 68.



## NUMSafe Architecture

The NUMSafe architecture is based on a Safe PLC (CTMP6900, CTMP1960-2600), Safe I/Os (CTMS1904, CTMS2904 and CTMS2912) and NUM-SAMX connected through the EtherCAT field bus. The safe PLC contains the programmed logic of the safety application, while the safe motion monitoring functions are handled by NUM-STO and NUM-SAMX module built into NUM DrivePro servo drives (see chapter 5).

2

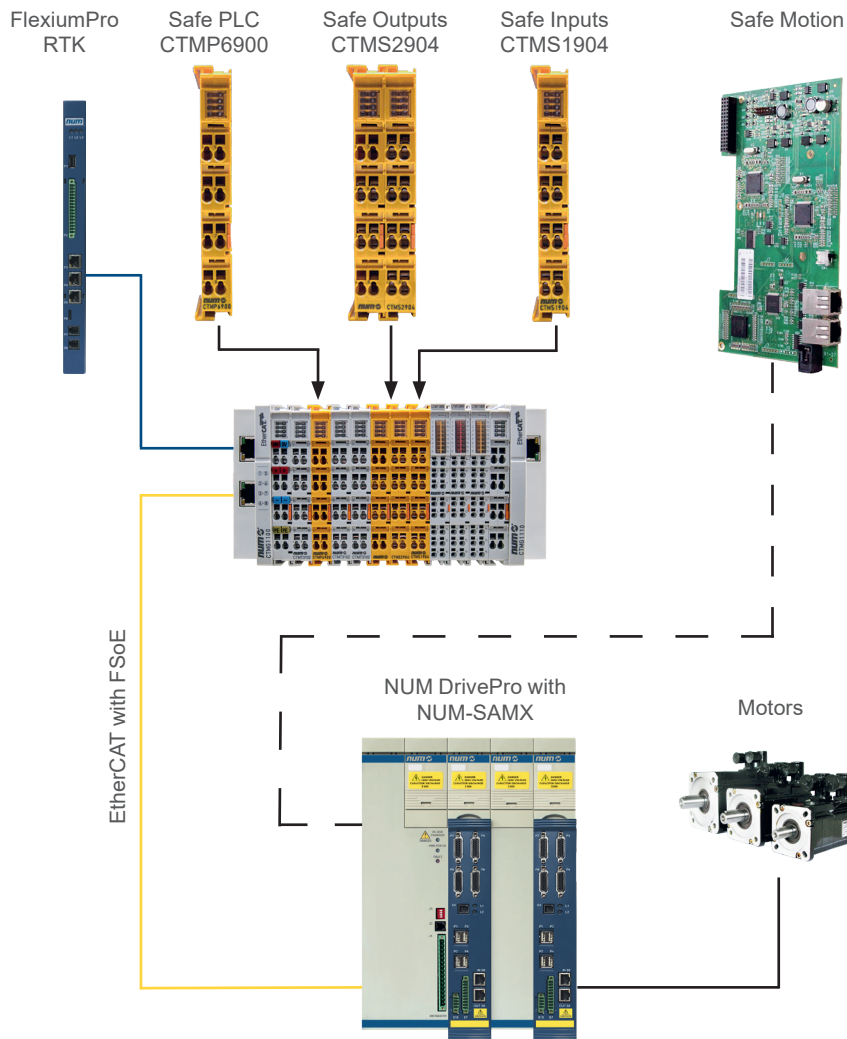

NUMSafe is a comprehensive solution for the functional safety management of each machine type. Architectures with mixed standard and safety related signals are possible (the safe PLC and I/Os can be positioned inside a standard terminal line up). All safety related and NON safety related data are transferred over the standard EtherCAT connection (FSoE), reducing wiring to the minimum and maximizing flexibility and scalability. The safety related devices are configured and programmed by means of the FlexiumPro Tools.

NUMSafe is compliant with EN13849-1 and EN61800-5-2 up to PL e and SIL 3 respectively.

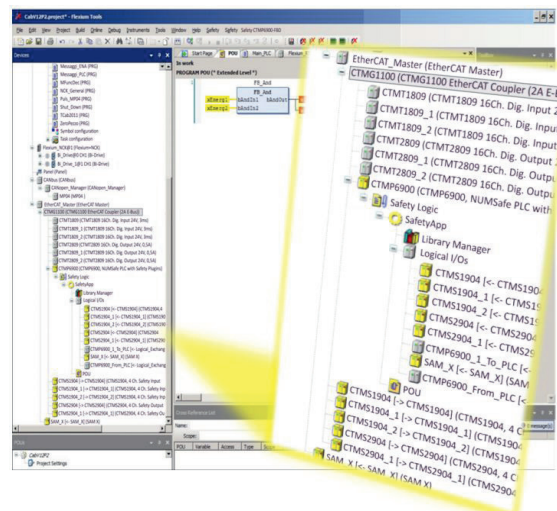

## NUMSafe Standard PLC Functions

NUMSafe PLC can establish 128 connections to other NUMSafe devices. Multiple NUMSafe PLCs are cascadable within a network. Safety functions such as emergency stop, safety door monitoring, two-hand control, etc. can thus easily be selected and linked. All blocks can be freely connected among each other and are complemented by operators such as AND, OR, etc. The required functions are configured via FlexiumPro Tools and loaded into the CTMP6900 (or CTMP1960-2600) NUMSafe PLC via the fieldbus.

The available function blocks are:

### FB\_AND

Using the FB\_AND function block, several input signals can be ANDed to make an output signal. In addition, a setting can be made for each input as to whether it is to be negated. This can be switched over using the „Negation“ command from the context menu.



### FB\_CS

A NUMSafe connection can be deactivated via the FB\_CONNECTION SHUTDOWN function block. If the input of the block becomes active the connection is terminated, a shutdown command is sent to the FSoE partner and a feedback signal is provided at the output. Furthermore, the connection is terminated and the output is set if a shutdown command is received from the communication partner.

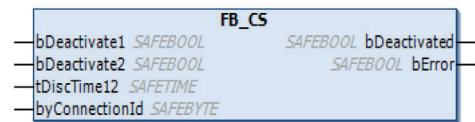

### FB\_DECOUPLER

The FB\_DECOUPLE function block serves to decouple signals from a NUMSafe connection. The function block has 8 inputs and 8 outputs, wherein the inputs are looped through to the outputs one-to-one. The corresponding output must be linked as soon as one of the inputs of the block is used. This also applies in the reverse direction.

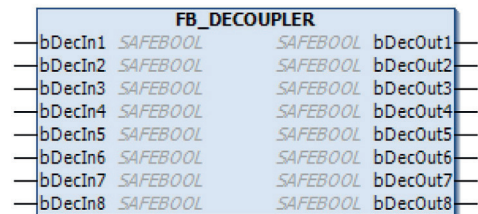

### FB\_EDM

The FB\_EDM function block (External Device Monitor) monitors the signals bMon1 and bMon2 over time. A switch-on and a switch-off monitor can be configured. In the default condition both monitors are inactive.



### FB\_ESTOP

An emergency stop circuit with up to eight emergency stop inputs (bEStopIn1 - bEStopIn8) can be implemented with the FB\_ESTOP function block. Each of the eight inputs can be negated using the „Negation“ command from the context menu. As soon as an input requests the safe state, the first output (EStopOut) immediately enters the safe state („0“) and the second output (EStop-DelOut) enters the safe state after a configurable time delay.

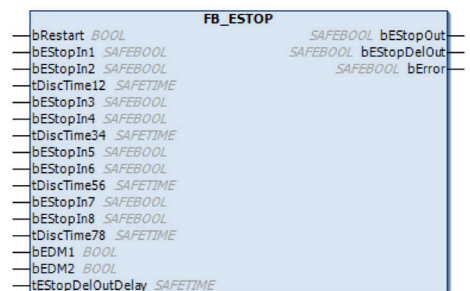





#### FB\_MON

A safety door circuit with up to four inputs (bMonIn(x)), for example, can be implemented with the FB\_MON function block. Each of the four inputs can be realized as a normally closed contact (break contact - 0 requests the safe state) or as a normally open contact (make contact - 1 requests the safe condition). As soon as an input requests the safe state, the first output (bMonOut) immediately enters the safe state („0“) and the second output (bMonDelOut) enters the safe state after a configurable time delay. By linking the FB output to several outputs, several immediately switching-off outputs (bMonOut) or delayed switching-off outputs (bMonDelOut) can be implemented with just one FB\_Mon.

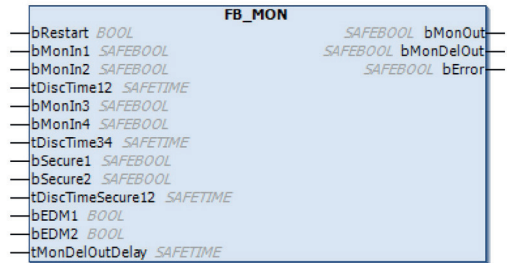

#### FB\_MUTING

The FB\_Muting function block implements an intended suppression of the safety function e.g. for the transport of material into the safety area. The output of the function block remains set even though the connected sensors are interrupted.

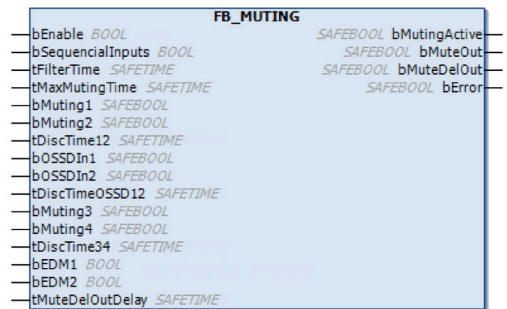

#### FB\_MODE

Operating mode selector switches can be implemented with the FB\_MODE function block. The function block has 8 inputs and 8 outputs, which are looped through one-to-one, whereby up to 8 different modes of operation can be selected. The FB\_MODE sets the corresponding output only if precisely one input is set („1“); the other outputs remain in the safe state („0“). If no input is set or if more than one is set, all outputs are in the safe state. If the bRestart input is activated, the safe state of the outputs is quit at the start and when changing the operating mode only via a 0->1->0 signal sequence at the Restart input. Beyond that a discrepancy time can be specified at the tDiscTime input with which the change from one mode of operation to the next is monitored.

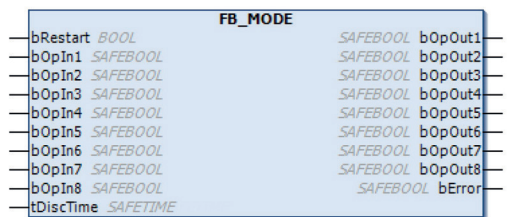

#### FB\_OR

Using the FB\_OR function block, several input signals can be ORed to make an output signal. In addition, a setting can be made for each input as to whether it is to be negated. This can be set using the „Negation“ command from the context menu.

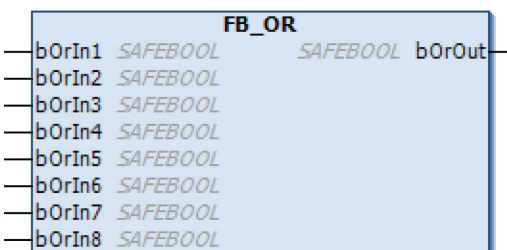





#### FB\_RS

The FB\_RS function block realizes a Reset/Set function. A logic 1 at the bSafeSet input and logic 0 at the bSafeReset input leads to a logic 1 at the output. A logic 0 at the bSafeSet input and logic 1 at the bSafeReset input leads to a logic 0 at the output. If both inputs are at logic 1, the Reset signal is dominant and leads to a logic 0 at the output. If both inputs are at logic 0, the output remains in its current state.



#### FB\_SR

The FB\_SR function block realizes a Set/Reset function. A logic 1 at the bSafeSet input and logic 0 at the bSafeReset input leads to a logic 1 at the output. A logic 0 at the bSafeSet input and logic 1 at the bSafeReset input leads to a logic 0 at the output. If both inputs are at logic 1, the Set signal is dominant and leads to a logic 1 at the output. If both inputs are at logic 0, the output remains in its current state.

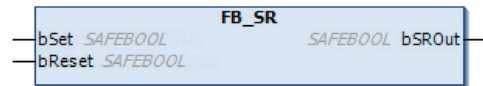

#### FB\_TOF

A switch-off delay is realized with the FB\_TOF function block. A logic 1 at the bTofIn input is extended by the set time and forwarded to the output. If the input is set to 1 again before the switch-off delay time is reached, the output remains switched on. The error output is inactive, since the block does not set errors.



#### FB\_TON

A switch-on delay is realized with the FB\_TON function block. A logic 1 at the bTonIn input is extended by the set time and forwarded to the output. If the input is set to 0 again before the delay time is reached, the output is not switched on. The error output is inactive, since the block does not set errors.



#### FB\_TWOHAND

The FB\_TWOHAND block implements a two-hand circuit in which both input groups must be actuated at the same time in order to switch the output. Renewed setting of the output is only possible if both input groups are at logic 0 at the same time.



## NUM DrivePro Standard Functions

---

### Motor Type and Control Method

NUM DrivePro accommodates open- and closed-loop control of different motor types:

- Closed loop with current vector control: synchronous rotary motors
- Closed loop with current vector control: synchronous torque and linear motors (optional for Bi-Axes and Quad-Axes drives, High Performance version is needed: MDLUF---BE-C----)
- Closed loop with current vector control: asynchronous rotary motors
- Open loop in V/f mode: synchronous and asynchronous rotary motors

### Motor Sensor

NUM DrivePro can interoperate with different motor feedback types:

- Sick Stegmann Hiperface encoder
- Heidenhain EnDat 2.1 & EnDat 2.2 encoder
- 1 Vpp toothed wheel / encoder
- Single cable motor sensor (encoder used in SHX, SPX motors)
- Renishaw RESOLUTE™ encoder with BiSS unidirectional interface
- Magnescale encoder

### High Performance Control Loop

NUM DrivePro features high internal resolution, a short sampling time (20 kHz) and specially developed control algorithms, which all contribute to its very wide bandwidth (optional for Bi-Axes and Quad-Axes drives, High Performance version is needed: MDLUF----EC----). The drive's wide bandwidth ensures exceptional dynamic performance, as well as precision and stiffness at the mechanical interface of the machine.

### Direct Measure Sensor (optional for Bi-Axes and Quad-Axes drives High Performance version is needed: MDLUF----EC----)

NUM DrivePro can interoperate with different direct measure sensor:

- EnDat 2.1 & EnDat 2.2 encoder / linear scale
- Hall sensors
- 1 Vpp encoder / linear scale (also with coded references)
- Renishaw RESOLUTE™ encoder with BiSS unidirectional interface
- Magnescale encoder

### EPS: Electrical Position Synchronization

To drive synchronous motors correctly, the relative position of the rotor (or magnet plates for linear motors) has to be known; this is typically realized by using and configuring absolute encoders (single or multi-turn). The EPS function allows incremental encoders to be used for this purpose; detection of the rotor (or magnet plates for linear motors) position is realized at each power on.

### AP01: Absolute Position with Motor's Multi-Turn Encoder and Incremental Direct Measure Sensor

The AP01 function allows the absolute position of an axis to be obtained from its motor's multi-turn encoder; the incremental direct measure sensor is initialized during initialization of the CNC-drive system.

The CNC won't require the homing on the axis even if the direct measure sensor is not absolute.

(Optional for Bi-Axes and Quad-Axes drives High Performance version is needed: MDLUF----EC----)



### AP02: Rotary Axes with Mechanical Ratio Different from 2<sup>n</sup>

The AP02 function provides absolute position management (without the need to perform the HOMING procedure), even in the case of rotary axes with a mechanical ratio between the motor sensor (or direct measure sensor) and the load which is not 2<sup>n</sup>. The function also allows machine lengths that exceed the maximum number of encoder revolutions to be managed as an absolute axis.

### AP06: Coherence Control between Motor and Direct Measure Sensor

The AP06 function controls the coherence between a motor and its direct measure sensor; its parameters define the maximum accepted displacement and the minimum time for which the displacement is accepted. (Optional for Bi-Axes and Quad-Axes drives High Performance version is needed: MDLUF---EC---)

### Digital Filters

Various digital filters are available, which can be freely set and cascaded to act at different points in the control loop. Types include first or second order low/high pass and notch filters, which can be applied to any combination of torque reference, speed reference. For speed feedback only first order low pass filter is allowed.

### AP11: Active Damping by VDR

As well as for measuring accelerations it can be used in closed loop to damp mechanical resonances. (Optional for Bi-Axes and Quad-Axes drives High Performance version is needed: MDLUF---EC---)

### AP12: Active Damping by Direct Measure Sensor

As well as digital filters which can be used to damp mechanical resonances, the active damping function is a complex closed loop algorithm particularly suitable for smoothing low frequency vibrations (below 150 Hz). (Optional for Bi-Axes and Quad-Axes drives High Performance version is needed: MDLUF---EC---)

## NUM DrivePro Optional Functions

### FPSO000453: Tandem Function (AP03, AP04)

#### Anti-Backlash Function (AP03):

Rack and pinion kinematic solutions usually have an unacceptable backlash; mechanical solutions to reduce backlash exist, but they decrease the efficiency of the transmission significantly, and deteriorate over time due to wear. The NUM DrivePro anti-backlash function provides a better approach, in which gear pinions are driven by two motors preloaded to compensate for the backlash. The function can be used for linear or rotary axes driven by synchronous or asynchronous motor. For proper functionality, the mechanical drive train from motor shaft to rack should be  $\geq 80\%$  efficient.

For implementing the anti-backlash function the following is needed:

- NCK Option FPSO000453
- A Bi-Axes or Quad-Axes drive in High Performance version is needed: MDLUF---EC---
- Two Mono-Axis drives with dedicated version: MDLUF---AED---

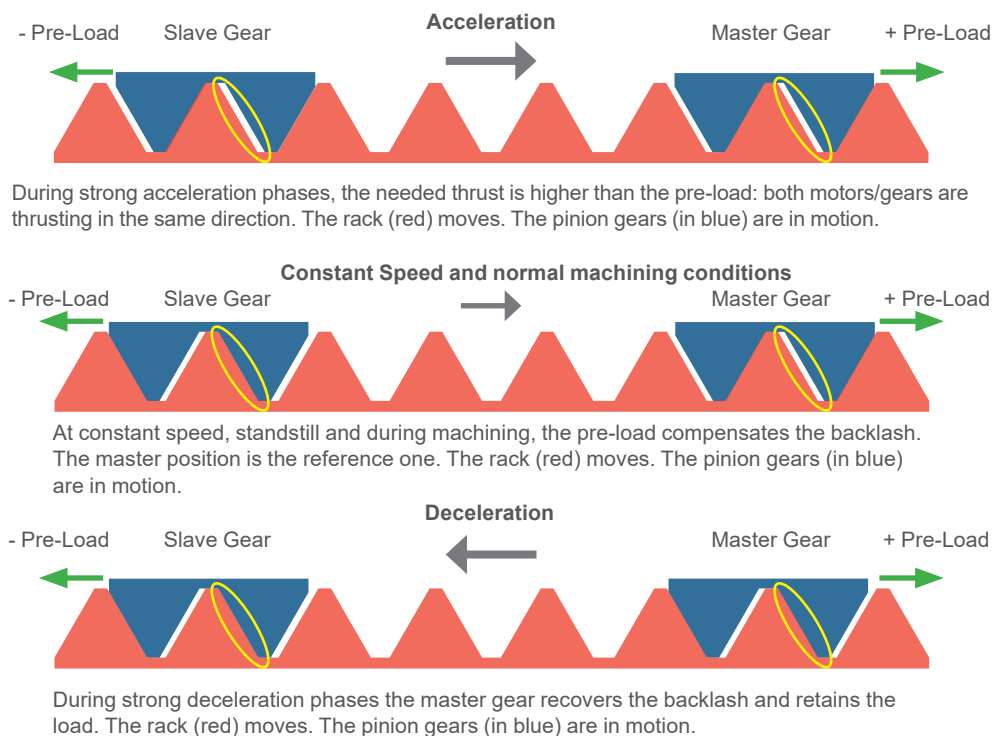

#### Torque Duplication (AP04)

Similar to the anti-backlash function, this allows two or more drives/motors to be electronically connected so that the torque/force supplied to the rack is the sum up of all motor forces.

- NCK Option FPSO000453
- A Bi-Axes or Quad-Axes drive in High Performance version is needed: MDLUF---EC--- (Limited to the motors in the drive)
- Two or three or four Mono-Axis drives with dedicated version: MDLUF---AED--- (The drives and the motor must be of the same size, one master and till three slaves are allowed)

#### FPSO100454: Winding Duplication (AP05)

Some specialized applications demand very high power motors (>>100 kW), with their windings divided into N independent sets. With NUM DrivePro it's possible to drive such independent windings by using N drives; the drives are hard synchronized so that the system performance is equivalent to a motor driven by one drive only.

- NCK Option FPSO100454
- A Bi-Axes or Quad-Axes drive in High Performance version is needed: MDLUF---EC--- (Limited to the motors in the drive)
- Two or three or four Mono-Axis drives with dedicated version: MDLUF---AED--- (The drives must be of the same size, one master and till three slaves are allowed)

#### FPSO000456: DEMF (Drive Embedded Macro / AP07)

This allows users to create their own real-time macro which can interact with all physical and virtual drive resources – even to the extent of manipulating the regulation algorithms. Users can design and implement filters and monitors, define test points and create pilot outputs that obey user-stipulated rules.

- NCK Option FPSO000456
- A Bi-Axes or Quad-Axes drive in High Performance version is needed: MDLUF---EC---
- Subject to international export control

#### AP08: Inter drive DEMF data exchange

This allows users to exchange data between two DEMF programs running on different axis on the same drive (Bi-Axes or Quad-Axes) or between two DEMF programs running on two Mono-Axis drive

- DEMF option is required

## Standard Safety Functions

As standard, NUM DrivePro servo drives are equipped with the NUM-STO safety module. This provides the Safe Torque Off function as specified by the EN 61800-5-2. When the STO function is activated NUM DrivePro will not provide the motor with any energy that could generate torque (or force in the case of a linear motor).

## Optional Safety Functions

The safe monitoring of axes' speed and position is carried out by NUM-SAMX safety module. NUM-SAMX interoperates by means of the EtherCAT (and FSoE) with the NUMSafe PLC and I/Os. NUM-SAMX is a hardware option of NUM DrivePro; please refer to chapter 8 for part number definition. NUM-SAMX performs the following safety functions:

#### Safe Torque Off (STO)

Like NUM-STO, NUM-SAMX provides the STO function but in this case the activation of the function is performed by means of the NUMSafe PLC and FSoE. When the STO function is activated NUM DrivePro will not provide the motor with any energy that could generate torque (or force in the case of a linear motor).

#### Safe Operational Stop (SOS)

The SOS function prevents the motor from deviating more than a defined amount from the stopped position. The NUM DrivePro provides energy to the motor to enable it to resist external forces.

#### Safe Stop 1 (SS1)

The SS1 function monitors the motor deceleration rate within set limits to stop the motor and initiates the STO function when the motor speed is below a specified limit.



#### **Safe Stop 2 (SS2)**

The SS2 function monitors the motor deceleration rate within set limits to stop the motor and initiates the safe operating stop function when the motor speed is below a specified limit.

#### **Safe Limited Speed (SLS)**

The SLS function prevents the motor from exceeding specified speed limit(s).

#### **Safe Limited Position (SLP)**

The SLP function prevents the axes from exceeding specified position limit(s).

#### **Safe Direction Monitoring (SDM)**

The SDI function prevents the motor shaft from moving in an unintended direction.

#### **Safe Interlock Signal**

NUM-SAMX provides a safe signal to indicate whether the motor speed is below a specified limit.

#### **Safe CAMs (SCA)**

The SCA function provides a safe output signal to indicate whether the motor shaft position is within a specified range.

#### **Safe Speed Monitor (SSM)**

The SSM function provides a safe output signal to indicate whether the motor speed is below a specified limit.



## FlexiumPro Main Component Summary

	FlexiumPro Main Component Summary
Industrial PC and operator panels	FS154i or FS184i or FS244i FS153 + Industrial Box PC
Machine Panel <sup>2</sup>	MP05 (FXHE03NBE1HN000) MP06 (FXHE02xxxxxxxxxx) MP07 (FXHE04xxxxxxxxxx) MP08 (FXHE01xxxxxxxxxx)
Portable Handwheel <sup>2</sup>	HBA (FXHE181xxx)
Real Time Kernel	FlexiumPro RTK <sup>1</sup>
I/Os System	NUMEtherCAT gateway and terminals (CTMG1100 + CTMTxxxx)
Safe PLC and Safe I/Os <sup>2</sup>	NUMSafe PLC and terminals (CTMP6900, CTMP1960-2600, CTMS1904, CTMS2904, CTMS2912)
Safe Motion Functions	NUM DrivePro with NUM-SAMX option (MDLUFxxxxExFN0x)
Digital CNC Servo Drives	NUM DrivePro (MDLUFxxxxExxN0x)
Servomotors	SHxxxxx SPxxxxx BHxxxxx BPxxxxx BPHxxxxx BPGxxxxx BHLxxxxx TMxxxxx
Spindle Motors	AMSxxxxx IMxxxxx

2

<sup>1</sup> Base component of a FlexiumPro system

<sup>2</sup> Optional

# FlexiumPro CNC System

## FlexiumPro Options Grid Summary Table Basic Features and Optional Extensions



### Basic Features and Optional Extensions

	FlexiumPro 6	FlexiumPro 8	FlexiumPro 68
<b>Axes + Spindle (digital and analog)</b>			
Base	5 <sup>1</sup>	5 <sup>2</sup>	5
Optional max	-	-	6 to 32
<b>Interpolated Axes per Channel</b>			
Base	4	4	4
Optional max	-	-	9
<b>Channels</b>			
Base	1	1	1
Optional max	-	2	32
<b>Handwheels</b>			
Base	0	0	0
Optional max	2	2	4
<b>CANopen Interfaces</b>			
Base	0	0	1
Optional max	1	2	2

<sup>1</sup> up to 4 axes and 1 spindle

<sup>2</sup> up to 5 axes or 4 axes and 1 spindle



# FlexiumPro CNC System

## FlexiumPro Options Grid Summary Table

### Machine Configuration



2

### Machine Configuration

	Reference	FlexiumPro 6	FlexiumPro 8	FlexiumPro 68
<b>Platforms</b>				
FlexiumPro 6	FPP1101100	●	-	-
FlexiumPro 8	FPP1101150	-	●	-
FlexiumPro 68	FPP2101200	-	-	●
<b>Configuration<sup>2</sup></b>				
Turning	FPSO200060	○	○	○
Milling	FPSO200061	○	○	○
<b>NCK Special Functions</b>				
NCK Digital Twin	FPPA000599	○	○	○
<b>Axes, Spindles or Measure inputs<sup>3</sup></b>				
6 <sup>th</sup> axis/spindle	FPSO100006	-	-	○
7 <sup>th</sup> + 8 <sup>th</sup> axis/spindle	FPSO100008	-	-	○
9 <sup>th</sup> up to 12 <sup>th</sup> axis/spindle	FPSO100012	-	-	○
13 <sup>th</sup> up to 16 <sup>th</sup> axis/spindle	FPSO100016	-	-	○
17 <sup>th</sup> up to 32 <sup>nd</sup> axis/spindle	FPSO100032	-	-	○
<b>Handwheels<sup>4</sup></b>				
1 <sup>st</sup> Handwheel	FPSO100375	○	○	○
2 <sup>nd</sup> Handwheel	FPSO100376	○	○	○
3 <sup>rd</sup> Handwheel	FPSO100377	-	-	○
4 <sup>th</sup> Handwheel	FPSO100378	-	-	○
<b>Interpolation capability</b>				
5 <sup>th</sup> interpolated axis <sup>1</sup>	FPSO100335	-	-	○
6 <sup>th</sup> interpolated axis <sup>1</sup>	FPSO100336	-	-	○
7 <sup>th</sup> interpolated axis <sup>1</sup>	FPSO100337	-	-	○
8 <sup>th</sup> interpolated axis <sup>1</sup>	FPSO100338	-	-	○
9 <sup>th</sup> interpolated axis <sup>1</sup>	FPSO100339	-	-	○
<b>Channels</b>				
2 <sup>nd</sup> channel	FPSO100392	-	○	○
3 <sup>rd</sup> + 4 <sup>th</sup> channel	FPSO100394	-	-	○
5 <sup>th</sup> + 6 <sup>th</sup> channel	FPSO100396	-	-	○
7 <sup>th</sup> + 8 <sup>th</sup> channel	FPSO100398	-	-	○
9 <sup>th</sup> + 10 <sup>th</sup> channel	FPSO100400	-	-	○
11 <sup>th</sup> + 12 <sup>th</sup> channel	FPSO100402	-	-	○
13 <sup>th</sup> + 14 <sup>th</sup> channel	FPSO100404	-	-	○
15 <sup>th</sup> + 16 <sup>th</sup> channel	FPSO100406	-	-	○
17 <sup>th</sup> + 18 <sup>th</sup> channel	FPSO100408	-	-	○
19 <sup>th</sup> + 20 <sup>th</sup> channel	FPSO100410	-	-	○
21 <sup>th</sup> + 22 <sup>nd</sup> channel	FPSO100412	-	-	○
23 <sup>rd</sup> + 24 <sup>th</sup> channel	FPSO100414	-	-	○
25 <sup>th</sup> + 26 <sup>th</sup> channel	FPSO100416	-	-	○
27 <sup>th</sup> + 28 <sup>th</sup> channel	FPSO100418	-	-	○
29 <sup>th</sup> + 30 <sup>th</sup> channel	FPSO100420	-	-	○
31 <sup>th</sup> + 32 <sup>nd</sup> channel	FPSO100422	-	-	○

<sup>1</sup> Subject to international export control

<sup>2</sup> The choice must be specified with the order

<sup>3</sup> Each axis, spindle or position measuring system counts as a device used to calculate the necessary option

<sup>4</sup> Handwheels are connected on an EtherCAT device

● Standard    ○ Optional    - Not Available

# FlexiumPro CNC System

## FlexiumPro Options Grid Summary Table Axes, Spindle and Machining Functions



### Axes, Spindle and Machining Functions

	Reference	FlexiumPro 6	FlexiumPro 8	FlexiumPro 68
<b>Axes functions</b>				
Duplicated and synchronized axes	FPSO000266	-	○	○
Inclined or tilted axes	FPSO000315	-	○	○
Conversion Cartesian to polar/cylindric	FPSO000340	-	○	○
Tool vector programming/3DWPC (G32/G34) <sup>9</sup>	FPSO000402	-	○	○
NURBS (B-Spline) interpolation <sup>2</sup>	FPSO000426	-	-	○
DEMF (Drive Embedded Macro / AP07) <sup>1</sup>	FPSO000456	-	○	○
Local contour rounding function (G164) <sup>8</sup>	FPSO000461	-	○	○
Linear feed variation (G94 EF1)	FPSO000462	○	○	○
Brake test	FPSO000463	○	○	○
Multi-turn encoder emulation	FPSO000464	-	○	○
Technological Feed Adaptation (TFA)	FPSO000466	○	○	○
Automatic Offset Compensation (AOC)	FPSO000467	○	○	○
Circular interpolation by three points	FPSO000497	-	○	○
Smooth polynomial interpolation <sup>3</sup>	FPSO000499	-	○	○
Radial axis boring / milling function (U-axis)	FPSO000514	-	○	○
Spline Interpolation (G06, G48, G49)	FPSO000518	-	○	○
Programmable precision <sup>1</sup>	FPSO000519	-	○	○
Multi-level Electronic Gear Box (MLEGB) <sup>1,5</sup>	FPSO000699	-	○	○
Tandem function (AP03, AP04)	FPSO000453	-	○	○
Winding duplication (AP05)	FPSO100454	-	○	○
Spline Interpolation with Curve Smoothing (G104)	FPSO181706	-	○	○
Adaptive Feed Control	FPSW282126	-	○	○
<b>Spindle functions</b>				
Spindle synchronization	FPSO000156	-	○	○
Sequenced thread cutting (G31/G38)	FPSO000331	-	○	○
Rigid Tapping	FPSO000332	-	○	○
<b>Machining functions</b>				
Rotation Tool Center Point (G26 RTCP)	FPSO000154	-	○	○
High Speed Cutting (HSC)	FPSO000155	-	○	○
Tilted Nozzle Management (TNM) <sup>9</sup>	FPSO000404	-	○	○
Advanced contour offset (C.OFF)	FPSO000465	-	○	○
Combined machine (turning + milling) <sup>4</sup>	FPSO000581	-	-	○
Fast Gear Alignment (FGA)	FPSO000595	-	○	○
NUMgrind GC Cycles	FPSO000681	○	○	○
NUMgrind Cyl. + Non-Circ. Grinding Cycles	FPSO000682	-	○	○
Milling and standard pocket cycles <sup>6</sup>	FPSO000695	-	-	○
Turning cycles <sup>7</sup>	FPSO000696	-	○	○
Trochoidal Milling Cycle (G725)	FPSO000700	-	○	○
Engraving Cycle (G730)	FPSO000701	○	○	○
Inclined plane machining	FPSO000914	-	-	○
Polygon-cutting cycles	FPSO100538	-	-	○

<sup>1</sup> Subject to international export control

<sup>2</sup> Includes FPSO000499, FPSO000518

<sup>3</sup> Includes FPSO000518

<sup>4</sup> Includes FPSO000331, FPSO000340, FPSO000514, FPSO000696, FPSO200060, FPSO200061

<sup>5</sup> Includes FPSO000082

<sup>6</sup> Includes FPSO200061

<sup>7</sup> Includes FPSO200060

<sup>8</sup> Needs FPSO000499

<sup>9</sup> Needs FPSO000154

#### Common features for all systems:

- Linear and circular interpolation
- Helical interpolation in milling systems
- Axis and Inter-axes calibration
- Jerk-controlled acceleration
- Anti-pitch correction
- Spindle indexing
- Spindle range automatic search
- Tangential control (G748)

● Standard

○ Optional

- Not Available



### CNC Programming, Tools and Operation

2

	Reference	FlexiumPro 6	FlexiumPro 8	FlexiumPro 68
<b>Programming functions</b>				
Dynamic operators <sup>1</sup>	FPSO000250	-	○	○
Early Block Change (G777 EBC)	FPSO000500	-	-	○
Scaling factor (G74)	FPSO000506	-	○	○
Angular program offset (ED)	FPSO000507	-	○	○
File handling in NC memory (G76)	FPSO000511	-	○	○
On the fly measurement / probing (G10)	FPSO000520	-	○	○
Structured and symbolic programming	FPSO000535	-	○	○
Building a profile table <sup>3</sup>	FPSO000536	-	○	○
<b>Tools functions</b>				
3D tool radius correction (G29)	FPSO000400	-	○	○
Extension to 255 offsets	FPSO000401	-	○	○
3D tool radius correction in RTCP (G43)	FPSO000411	-	-	○
Tool management	FPSW282119	○	○	○
<b>Machine operations</b>				
N/M Auto	FPSO000082	-	○	○
Emergency retract (G75)	FPSO000505	-	○	○
Backtrack along stored path	FPSO000523	-	○	○
<b>Compensations</b>				
VEComp 3-/4-axes <sup>1</sup>	FPSO000458	○	○	○
VEComp 5-axes <sup>1</sup>	FPSO000459	○	○	○
VEComp rotary axes <sup>1</sup>	FPSO000460	-	-	○
<b>Measuring functions</b>				
Kinematic measurement cycle <sup>4</sup>	FPSO000153	-	-	○
Probing cycles for turning	FPSO100590	-	○	○
Probing cycles for milling	FPSO100591	-	○	○

<sup>1</sup> Subject to international export control

<sup>2</sup> Includes FPSO000250

<sup>3</sup> Includes FPSO000535

<sup>4</sup> Requires FPPA000560

#### Common features for all systems:

- Parametric programming
- Profile Geometric Programming
- Inch / Metric conversion
- 32 Tool offsets
- Radius and length compensation
- Tool wear offset by the PLC
- Tool axis selection

● Standard      ○ Optional      - Not Available



### PLC Functions

	Reference	FlexiumPro 6	FlexiumPro 8	FlexiumPro 68
CAN Interface	FPSO000430	○	○	●
Extended NCK access	FPSW282124	○	○	○
EtherCAT Safe PLC	FPSW282305	○	○	○

● Standard      ○ Optional      - Not Available



### HMI Functions

	Reference	FlexiumPro 6	FlexiumPro 8	FlexiumPro 68
<b>Visualization</b>				
CODESYS Option: Remote Target Visualisation	FPSW282302	○	○	○
CODESYS Option: WEB Visualization	FPSW282303	○	○	○

### Flexium 3D Functions

	Reference	FlexiumPro 6	FlexiumPro 8	FlexiumPro 68
3D Simulation with online collision detection	FPSO000521	○	○	○
3D Simulation with material removal	FPSW282153	○	○	○
3D Simulation with collision detection	FPSW282154	○	○	○
Online simulation	FPSW282155	○	○	○
3D Machine editor	FPSW282156	○	○	○
3D Graphical SEARCH Mode	FPSW282157	○	○	○
3D-Path Editor	FPSW282158	○	○	○

● Standard      ○ Optional      - Not Available



### Option Packs - Description

For an optimal system configuration, the options are regrouped in different technology packs. The list below defines the packs and their availability according to each system.

		Reference	FlexiumPro 6	FlexiumPro 8	FlexiumPro 68
<b>CNC/HMI Option Packs</b>					
<b>T</b>	Turning Pack	FPPA000555	○	○	○
<b>M0</b>	Basic Milling Pack	FPPA000560	○	○	○
<b>M1<sup>2</sup></b>	Milling Pack 1	FPPA000561	-	-	○
<b>M2<sup>1,2</sup></b>	Milling Pack 2	FPPA000562	-	-	○
<b>M3<sup>1,2</sup></b>	Milling Pack 3	FPPA000563	-	-	○
<b>HSC<sup>2</sup></b>	High Speed Cutting Pack	FPPA000564	-	-	○
<b>AM<sup>1,2</sup></b>	Aluminum Machining Pack	FPPA000566	-	-	○
<b>CUT<sup>2</sup></b>	Cutting Pack	FPPA000567	-	○	○
<b>W1<sup>1,2</sup></b>	Woodworking Pack	FPPA000576	-	-	○
<b>TR<sup>1</sup></b>	Tool Grinding Pack	FPPA000586	-	-	○
<b>GS0<sup>1</sup></b>	Surface Grinding Pack 0	FPPA000587	-	○	○
<b>GC0<sup>1</sup></b>	Cylindrical Grinding Pack 0	FPPA000588	-	○	○
<b>GC1<sup>1</sup></b>	Cylindrical Grinding Pack 1	FPPA000592	-	○	○
<b>CNCG<sup>1</sup></b>	Cylindrical + Non-circular Grinding Pack <sup>1</sup>	FPPA000593	-	○	○
<b>GTWG<sup>1</sup></b>	Threaded Wheel Grinding Pack	FPPA000589	-	○	○
<b>GH1</b>	Gear Hobbing Pack 1	FPPA000596	-	○	○
<b>GH3<sup>1</sup></b>	Gear Hobbing Pack 3	FPPA000598	-	○	○
<b>GSH</b>	Gear Shaping Pack	FPPA000590	○	○	○
<b>Flexium 3D Option Packs</b>					
<b>WJC</b>	Flexium 3D Water Jet Cutting Package	FPSW282170	○	○	○

<sup>1</sup> Subject to international export control

<sup>2</sup> Pack M0 is required

● Standard      ○ Optional      - Not Available



### CNC Option Pack Contents Part 1

	Reference	M0	M1 <sup>2</sup>	M2 <sup>1,2</sup>	M3 <sup>1,2</sup>	HSC <sup>2</sup>	T	W1 <sup>1,2</sup>	AM <sup>1,2</sup>	CUT <sup>1,2</sup>
Rotation Tool Center Point (G26 RTCP)	FPSO000154			■	■			■	■	■
High Speed Cutting (HSC)	FPSO000155					■		■		
Sequenced thread cutting (G31/G38)	FPSO000331						■			
Rigid Tapping	FPSO000332		■		■					
5 axis interpolation	FPSO100335			■	■			■	■	
3D tool radius correction (G29)	FPSO000400		■		■			■		
255 Tool offsets	FPSO000401	■	□	□	□	□		□	□	□
Tilted Nozzle Management (TNM)	FPSO000404									■
3D tool radius correction in RTCP (G43)	FPSO000411			■	■	■		■		
Local contour rounding function (G164)	FPSO000461					■				
Circular interpolation by three points	FPSO000497	■	□	□	□	□	■	□	□	□
Polynomial Interpolation	FPSO000499					■				
Scaling factor (G74)	FPSO000506	■	□	□	□	□	■	□	□	□
Angular program offset (ED)	FPSO000507	■	□	□	□	□	■	□	□	□
File handling in NC memory (G76)	FPSO000511	■	□	□	□	□	■	□	□	□
Spline interpolation	FPSO000518					■				
On the fly measurement / probing (G10)	FPSO000520	■	□	□	□	□	■	□	□	□
Structured and symbolic programming	FPSO000535	■	□	□	□	□	■	□	□	□
Milling cycles	FPSO000695	■	□	□	□	□		□	□	□
Turning cycles	FPSO000696						■			
Trochoidal Milling Cycle (G725)	FPSO000700		■							
Engraving Cycle (G730)	FPSO000701	■	□	□	□	□		□	□	□
Inclined plane machining	FPSO000914		■	■	■				■	

<sup>1</sup> Subject to international export control

<sup>2</sup> Pack M0 is required

■ option included in the pack

□ option implied by the mandatory pack (M0 or T)



# FlexiumPro CNC System

## FlexiumPro Options Grid Summary Table Option Pack Contents



### CNC Option Pack Contents Part 2

	Reference	TR <sup>1</sup>	GH1	GH3 <sup>1</sup>	GTWG <sup>1</sup>	GSH	GC0 <sup>1</sup>	GC1 <sup>1</sup>	CNCG <sup>1</sup>	GS0 <sup>1</sup>
N/M Auto	FPSO000082								■	
Sequenced thread cutting (G31/G38)	FPSO000331				■		■	■	■	
5 axis interpolation	FPSO100335	■								
Conversion Cartesian to polar/cylindrical	FPSO000340								■	
Advanced Contour Offset (C.OFF)	FPSO000465								■	
Circular interpolation by three points	FPSO000497	■					■	■	■	■
Emergency retract (G75)	FPSO000505		■	■	■	■	■	■	■	■
Scaling factor (G74)	FPSO000506						■	■	■	■
Angular program offset (ED)	FPSO000507						■	■	■	■
File handling in NC memory (G76)	FPSO000511	■	■	■	■		■	■	■	■
Programmable precision	FPSO000519	■					■	■	■	■
On the fly measurement / probing (G10)	FPSO000520	■	■	■	■		■	■	■	■
Structured and symbolic programming	FPSO000535	■	■	■	■	■	■	■	■	■
Building a profile table	FPSO000536								■	
Spline Interpolation	FPSO000518				■					
Fast Gear Alignment (FGA)	FPSO000595				■					
NUMgrind GC Cycles	FPSO000681							■		
NUMgrind Cyl.+Non-Circ. Grinding Cycles	FPSO000682								■	
NUMgear Hobbing Cycles	FPSO000690		■	■						
NUMgear TWG Cycles	FPSO000691				■					
NUMgear Shaping Cycles	FPSO000692					■				
Milling cycles	FPSO000695									■
Turning cycles	FPSO000696						■	■	■	
Simple Electronic Gear Box	FPSO000698		■							
Multi-level Electronic Gear Box (MLEGB)	FPSO000699			■	■				■	
2 <sup>nd</sup> channel	FPSO100392						■	■	■	■
Spline Interpolation with Curve Smoothing (G104)	FPSO181706				■					

### Flexium 3D Option Pack Contents

	Reference	WJC
3D Simulation material removal	FPSW282153	■
Online Simulation	FPSW282155	■
Graphical SEARCH mode	FPSW282157	■

<sup>1</sup> Subject to international export control

■ option included in the pack

□ option implied by the mandatory pack (M0 or T)



### NUM DrivePro Functions

2

		Bi-Axes and Quad-Axes SP (Standard Performance)	Mono-Axis, Bi-Axes and Quad-Axes HP (High Performance)
Interface	EtherCAT with NUM device profile	●	●
Control Performance	Standard performance control loops	●	●
	High performance control loops	-	●
Compatible Motors	Closed loop: synchronous rotary motors <sup>1</sup>	● <sup>2</sup>	●
	Closed loop: synchronous torque and linear motors	-	●
	Closed loop: asynchronous motors	●	●
	Open loop: synchronous or asynchronous rotary motors (V/F mode)	●	●
Compatible Motor Sensor	Single cable motor encoder (SHX, SPX motors)	●	●
	EnDat 2.1 & EnDat 2.2 encoder	●	●
	1 Vpp toothed wheel / encoder	●	●
	Renishaw RESOLUTE™ encoders with BiSS unidirectional interface	●	●
	Magnescale encoders	●	●
Compatible Direct Measure Sensors	EnDat 2.1 & EnDat 2.2 encoder / linear scale	-	●
	Hall sensors	-	●
	1 Vpp encoder / linear scale (also with coded references)	-	●
	Renishaw RESOLUTE™ encoder with BiSS unidirectional interface	-	●
Special Functions	Magnescale encoders	-	●
	Spindle operation for synchronous and asynchronous motors	●	●
	Synchronous motor phasing without movement <sup>3</sup>	●	●
	Spindle-Axis commutation	●	●
	Rotary axis with mechanical ratio not 2 <sup>n</sup> (AP02)	●	●
	Anti-backlash function (AP03) <sup>4,5</sup>	-	○
	Torque duplication (AP04) <sup>5,6</sup>	-	○
	Winding duplication (AP05) <sup>5,6</sup>	-	○
DEMF (Drive Embedded Macro / AP07) <sup>7</sup>	-	○	
Special Functions	Coherence control between motor and direct measure sensor (AP06)	-	●
	Various active damping functions	-	●
	Various freely settable filters (AP11, AP12)	●	●
	Electrical Position Synchronization (EPS)	●	●
	Absolute position with motor's multi-turn encoder and incremental direct measure sensor	-	●

<sup>1</sup> Having a compatible position sensor  
<sup>2</sup> For standard performance, max. 8 pole pairs motors  
<sup>3</sup> Required with incremental encoders  
<sup>4</sup> Not allowed for asynchronous motors in V/F mode  
<sup>5</sup> On Mono-axis drive, available with dedicated version MDLUF---AED---  
<sup>6</sup> Not allowed for asynchronous motors  
<sup>7</sup> Subject to international export control

● Standard      ○ Optional      - Not Available



### NUM DrivePro Functions

		Bi-Axes and Quad-Axes SP (Standard Performance)	Mono-Axis, Bi-Axes and Quad-Axes HP (High Performance)
Safety Functions compliant with EN 61800-5-2	NUM-STO module with Safe Torque Off <sup>8</sup>	○	○ <sup>9</sup>
	NUM-SAMX module with <ul style="list-style-type: none"> <li>• STO Safe Torque Off</li> <li>• SLS Safely Limited Speed</li> <li>• SOS Safe Operational Stop</li> <li>• SS1 Safe Stop 1</li> <li>• SS2 Safe Stop 2</li> <li>• SLP Safe Limited Position</li> <li>• SDM Safe Direction Monitoring</li> <li>• SCA Safe CAMs</li> <li>• SSM Safe Speed Monitor</li> </ul>	○	○ <sup>9</sup>

<sup>8</sup> Not Available on Quad-Axes drive

<sup>9</sup> Not available on MDLUF200

● Standard      ○ Optional      - Not Available

### FS184i and FS244i Operator Panels with Integrated iPC

FS184i P2 and FS244i P2 are, respectively, 18.5 inch and 24 inch operator panels with integrated iPC; the display, glass protected, integrates a projected capacitive multi-touch screen system.

They are durable, modern front end for machine control. They have an IP65 degree of protection at the front, and IP20 at the rear. FS184i P2 and FS244i P2 include the well-known NUM Industrial PC P2.

For these new operator panels, virtual key boards / machine panels are not yet available.

They can be mounted in landscape or portrait format.

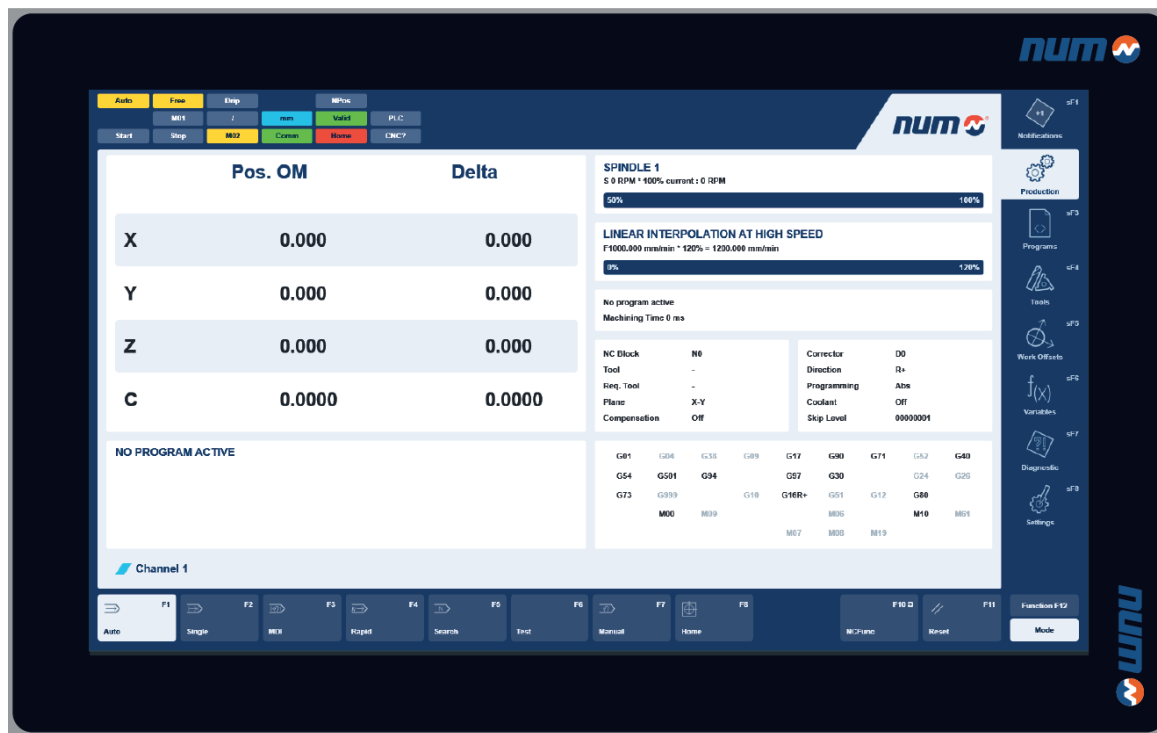

#### FS184i and FS244i (with Integrated iPC) Technical Characteristics

		FXPC184CN2SNR20	FXPC244CN2SNR20
Screen	Type	Projected capacitive touch screen with glass protection	
	Technology	18.5" TFT LCD (16.9 million colors)	24" TFT LCD (16.9 million colors)
	Resolution	1366 x 768	1920 x 1080
	Screen Diagonal	409.8 x 230.4mm	531.3 x 298.8mm
	Backlight	LED, Contr. 1000:1	LED, Contr. 5000:1
Main PC Features	CPU	i5-6500TE 2.3GHz Quad Core 6th generation	
	RAM	8 GB	
	Mass storage	SSD 64 GB	
	Operating system	Windows 10 IoT Enterprise LTSB 64 bits	
Communication Interfaces	Ethernet (ETH)	3 x Gigabit LAN / RTE	
	USB	2 x USB 2.0 Type A / 4 x USB 3.0 Type A (rear)	
	Serial interface	2 x COM	
	DVI-D	1	
	HDMI	1	
Power Supply	Rated voltage	24VDC (+15%/-15%) SELV	
	Protection against reverse polarity	Yes	
	Protection against over voltage	Yes	
	Potential isolation	No. (The 0V-pin of the PS is connected to the digital GND)	
	Power consumption	55 W typ., max. 120 W (5A)	63 W typ., max. 120 W (5A)
Ambient Conditions	Climatic conditions operation	5..45°C, 70% rel. air humidity, non-condensing	
	Climatic storage conditions	-20...60°C, 70% rel. air humidity, non-condensing	
	Climatic conditions transport	-20...60°C, 90% rel. air humidity, non-condensing	
Degree of Protection	Front	IP 65	
	Rear	IP 20	
Weight		6.7 kg	8.9 kg
Dimensions	W x H x D	488 x 309 x 71 mm	621.5 x 389 x 76 mm
Cooling		With fan	

#### FS184i (with Integrated iPC) Outlines Dimensions

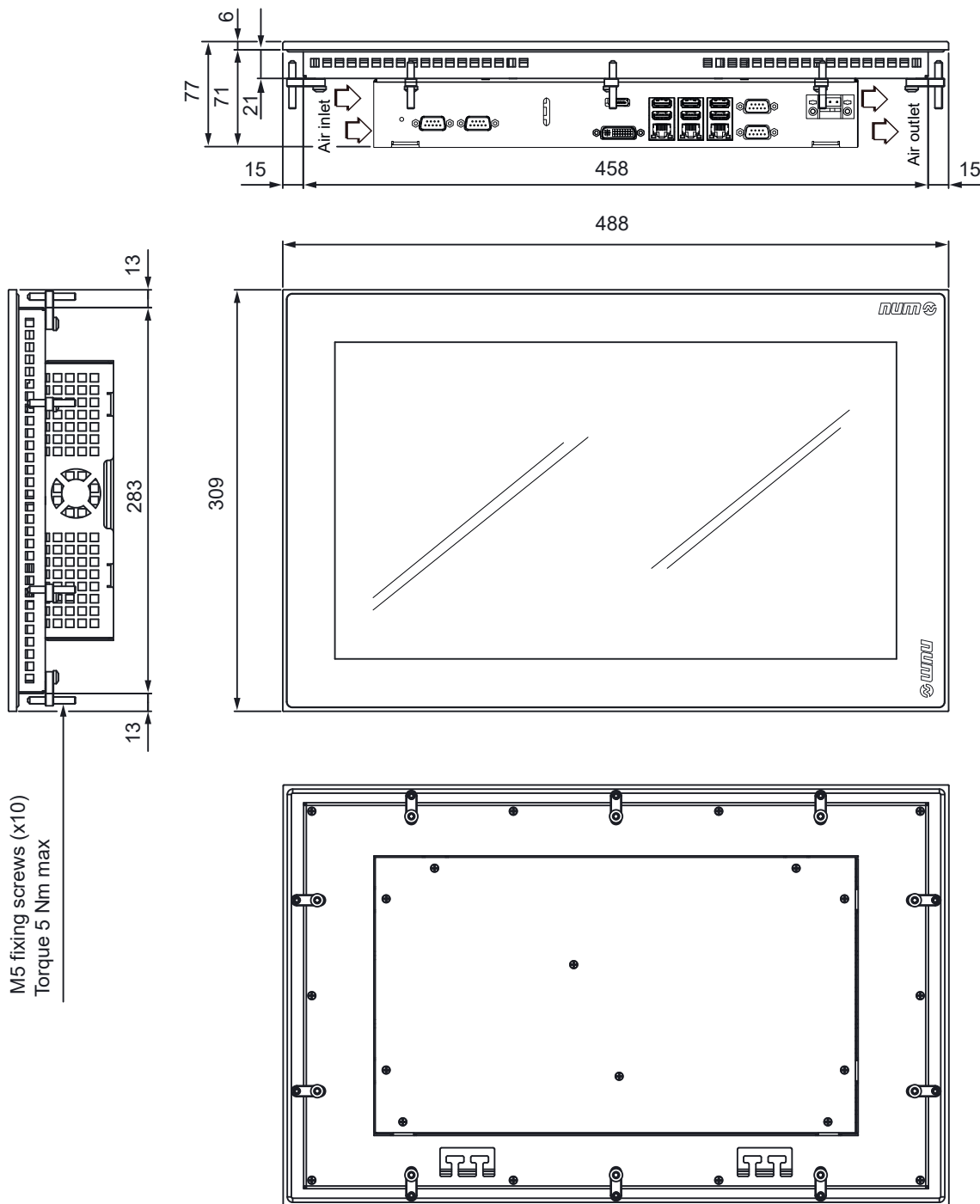

## FS184i (with Integrated iPC) Outlines Cut-out area

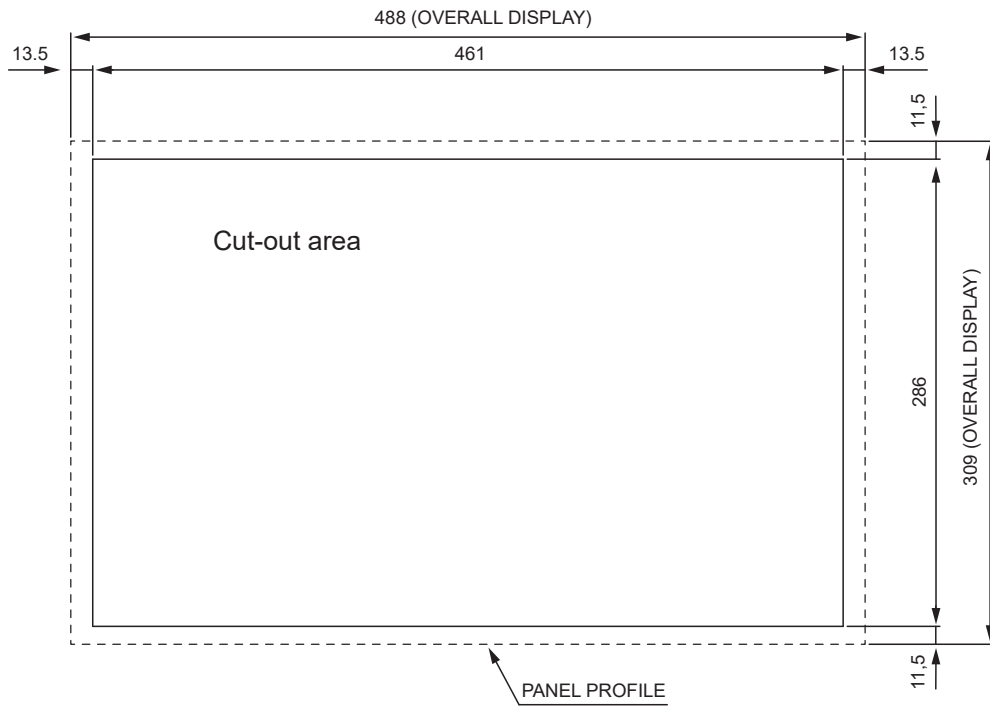



#### FS244i (with Integrated iPC) Outlines Dimensions

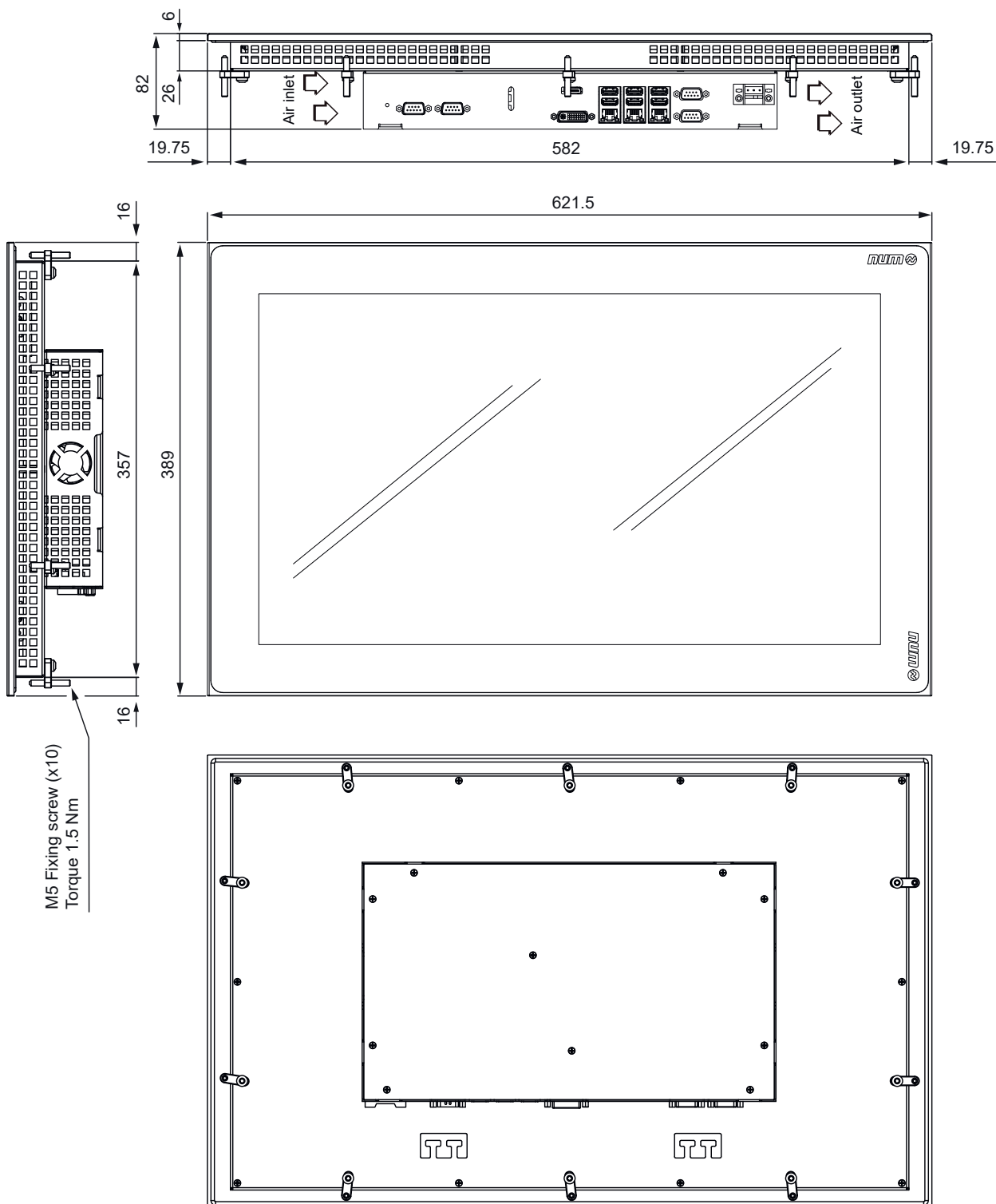

## FS244i (with Integrated iPC) Outlines Cut-out area

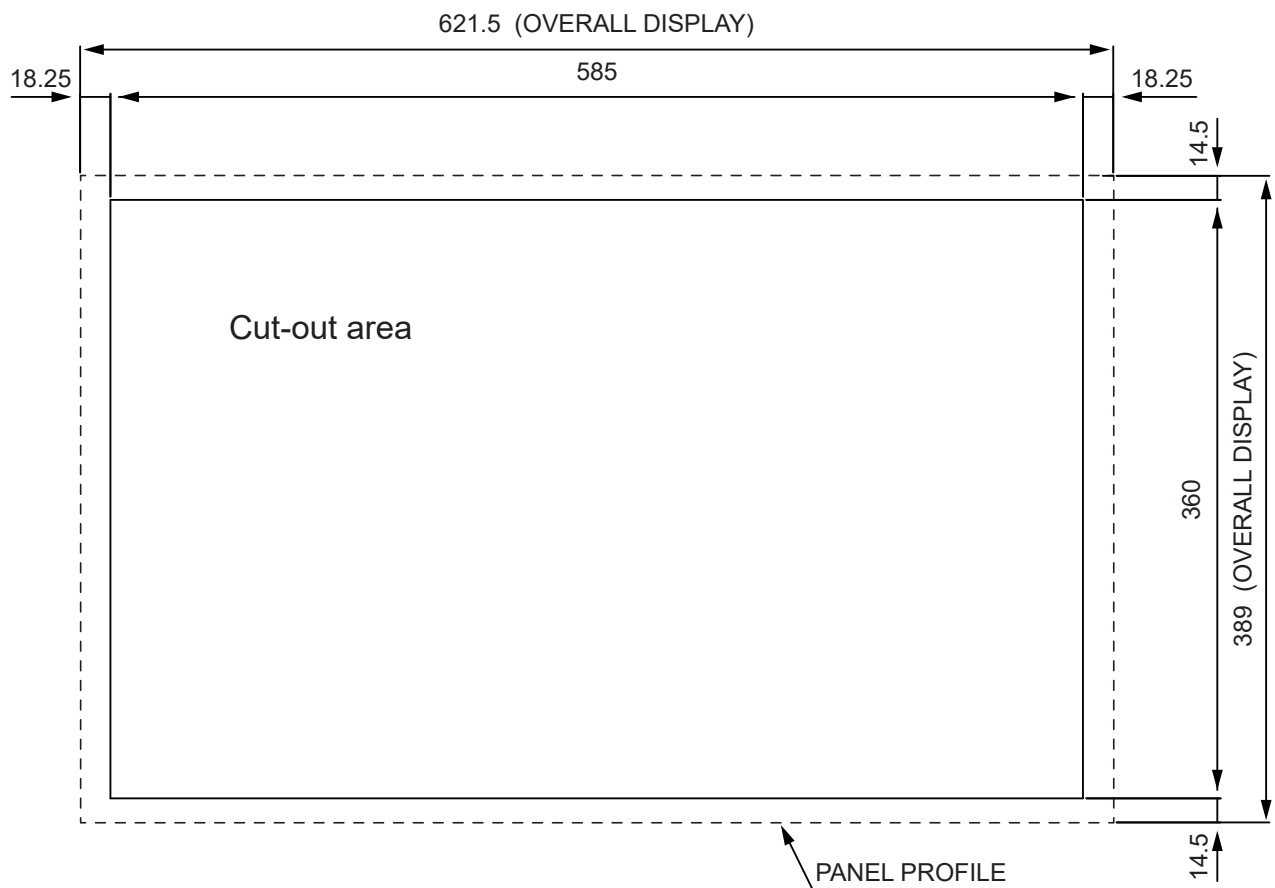

# Operator Panels and Industrial PC

## FS184i and FS244i Operator Panels with Integrated iPC

### Ordering Codes

#### Operator Panel FS184i and FS244i Ordering codes

Version	Ordering Codes
FS184i - P2 SSD	FXPC184CN2SNR20
FS244i - P2 SSD	FXPC244CN2SNR20

“x” can be either “C” or “Z” in case of customized PC.

3

	FXPC	18	4	C	N	2	S	N	R	2	0
<b>Display Unit</b>											
• LCD 18.5"		18									
• LCD 24"		24									
<b>Panel/Mechanical Variant</b>											
• Fourth generation			4								
<b>Display Sensor</b>											
• Touch Screen projective capacitive				C							
<b>Keyboard Type</b>											
• No keyboard, No function keys					N						
<b>IPC Mother Board, Processor</b>											
• Performance level P2						2					
<b>Mass Memory Type</b>											
• SSD (Solid State Disc)							S				
<b>Option Board</b>											
• None								N			
<b>Fixed Value</b>											
									R		
<b>Operating System</b>											
• Windows 10 kernel 64 bits										2	
<b>Spare Number</b>											0

## FS154i Operator Panels with Integrated iPC

### FS154i Operator Panels with Integrated iPC

FS154i PC panels provide a powerful and ergonomic platform for the FlexiumPro HMI, enabling you to interact with the machine in a simple and logical manner. The integrated PCs use modern quad-core processor.

Depending on the application, you can choose the user interface:

- With 22 large function keys (keyboard option F)
- With 22 large function keys and an expanded QWERTY keyboard (keyboard option Q)
- Touch screen available as option

The display quality of their 15.1" screen makes the panels very legible even in poorly-lit environments. Compact and very rugged, the panels are sealed (IP65) and suitable for use in severe industrial environments.

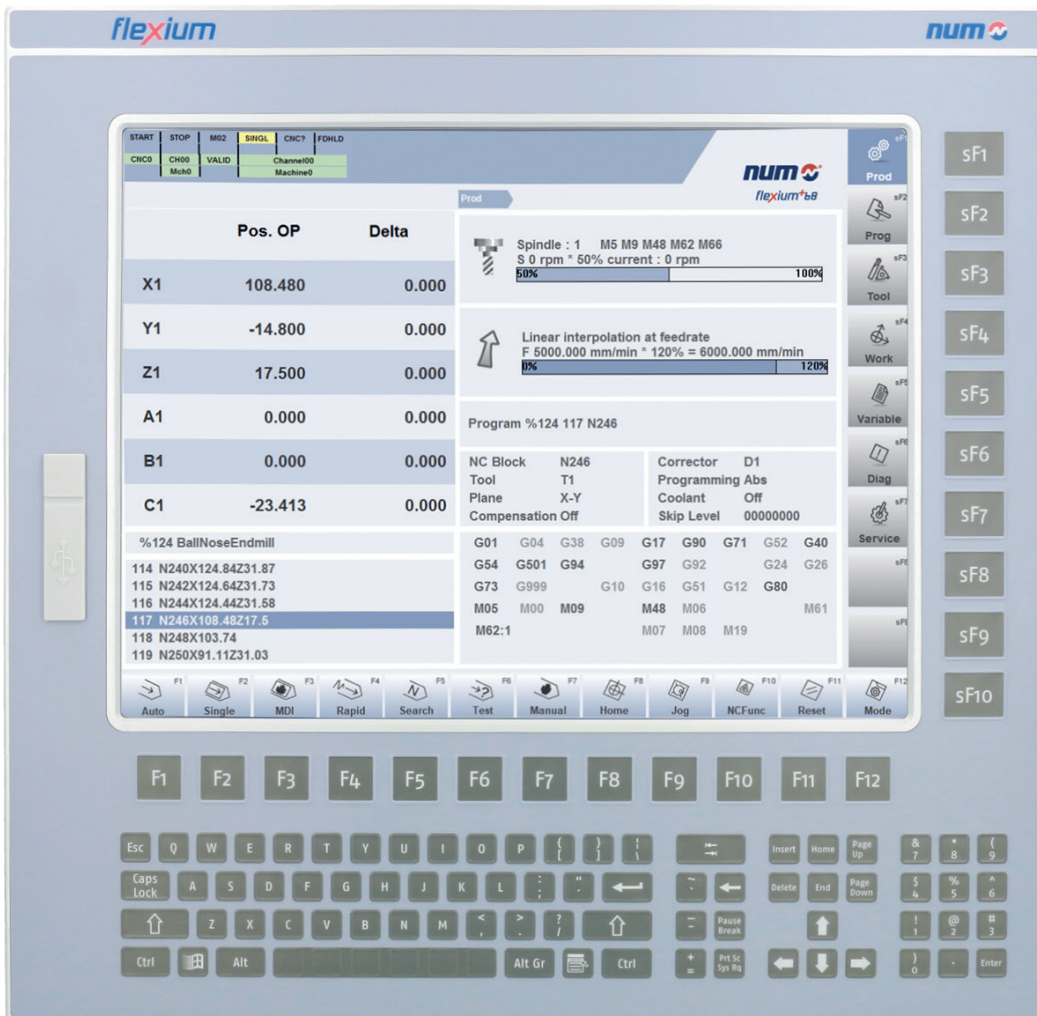

### FS154i Operator Panels Interface Options

3



Panel with 22 Function Keys  
Reference with PC Panel coding "F"

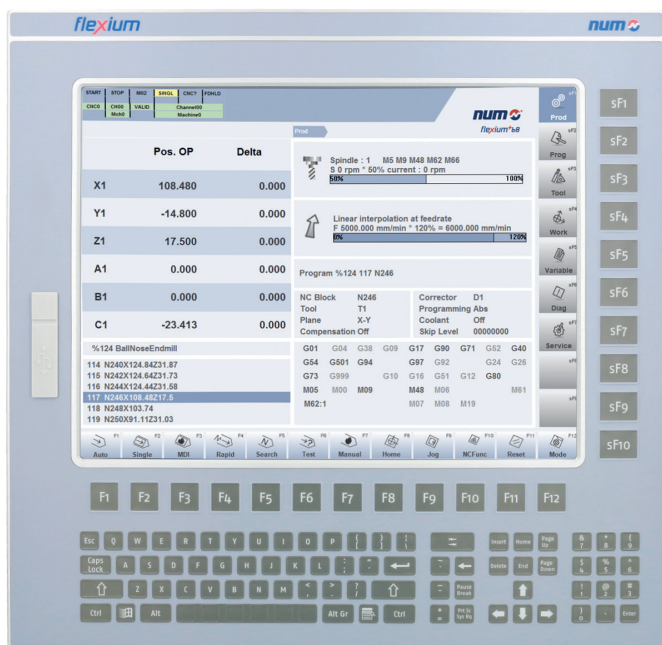

Panel with 22 Function Keys and QWERTY-Keyboard  
Reference with PC Panel coding "Q"



### FS154i Operator Panel with integrated iPC

		<b>FXPC154xx2SNR20 (FS154 P2)</b>
Screen	User interface options	Active panel with integrated PC with: <ul style="list-style-type: none"> <li>• 22 Function Keys</li> <li>• 22 Function Keys and Qwerty Keyboard</li> <li>• Touch Screen (resistive)</li> </ul>
	Technology	15" TFT LCD (16.9 million colors)
	Resolution	1024 x 768 from 60Hz to 75Hz
	Size	304 x 228 mm (12 x 9 inch)
	Backlight	LED, Contr. 700:1 (Type)
Main PC Features	CPU	Intel® i5-6500TE 2.3GHz Quad Core 6th generation
	RAM	8 GB
	Mass storage	SSD 64 GB
	Operating system	Windows 10 IoT Enterprise LTSC 64 bits
Communication Interfaces	Ethernet (ETH)	3 x Gigabit LAN / RTE
	USB front	1 x USB 2.0 Type A
	USB rear	2 x USB 2.0 Type A / 4 x USB 3.0 Type A
	Serial interface	2 x COM
	DVI	Yes
	CRT monitor	No
	HDMI	Yes
Power Supply	Rated voltage	24 VDC (+15%/-15%) SELV
	Protection against reverse polarity	Yes
	Protection against over voltage	Yes
	Potential insulation	No, the 0V pin is connected to the digital GND
	Power consumption	typ. 48 W max. 96 W (4A)
Ambient Conditions	Climatic conditions operation	0..45°C, 70% rel. air humidity, non-condensing
	Climatic storage conditions	-20...60°C, 70% rel. air humidity, non-condensing
	Climatic conditions transport	-20...60°C, 90% rel. air humidity, non-condensing
Degree of Protection	Front	IP 65
	Rear	IP 20
	Pollution degree	2
Weight		ca. 6.1 kg Function Key version ca. 6.5 kg Full Qwerty version
Dimensions	W x H x D	410 x 330 (400) x 72.3mm
Cooling		With fan

#### FS154i Outline Dimensions (dashed lines FQ version)

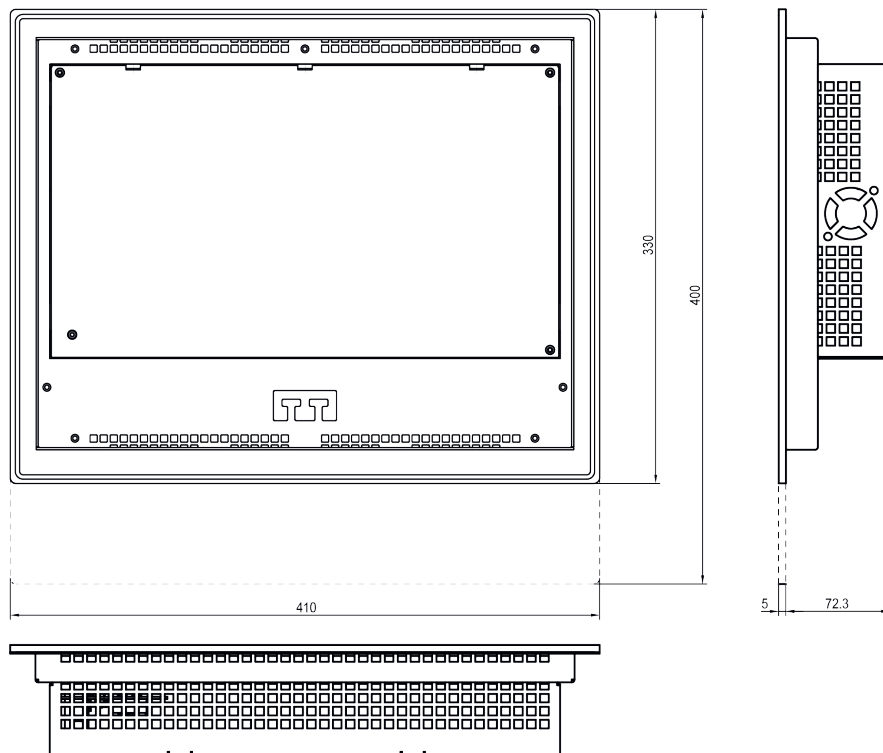

Dashed line FS154xQ version only.

Dashed line FS154xQ version only.

#### FS154i Cut-Out

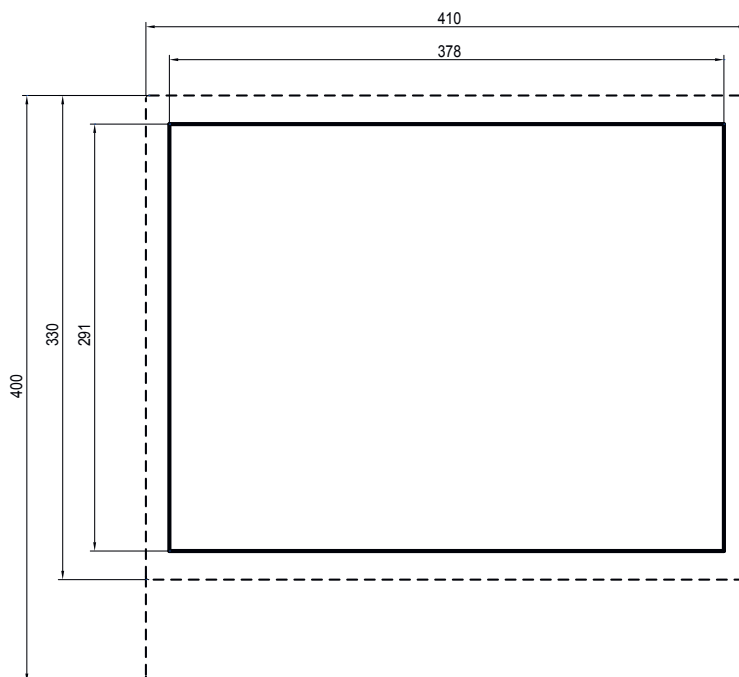

Dashed lines shows the panel dimensions.



# Operator Panels and Industrial PC

## FS154i Operator Panels with Integrated iPC

### Ordering Codes

#### Operator Panel FS154i Available Versions

FS154i Version	Ordering Codes
FS154i-FK P2 SSD	FXPC154NF2SNR20
FS154i-FQ P2 SSD	FXPC154NQ2SNR20
FS154i-FK TS P2 SSD	FXPC154RF2SNR20
FS154i-FQ TS P2 SSD	FXPC154RQ2SNR20

	FXPC	15	4	N	F	2	S	N	R	2	0
<b>Display Unit</b> • LCD 15"		15									
<b>Panel/Mechanical Variant</b> • Fourth Generation			4								
<b>Display Sensor</b> • Touch Screen resistive • No Sensor				R N							
<b>Keyboard Type</b> • 22 Function keys • 22 Function keys + Qwerty Keyboard					F Q						
<b>IPC Mother Board, Processor</b> • Performance level P2						2					
<b>Mass Memory Type</b> • SSD (Solid State Disc)							S				
<b>Option Board</b> • None								N			
<b>Fixed Value</b>									R		
<b>Operating System</b> • Windows 10 kernel LTSB 64 bits										2	
<b>Spare Number</b>											0

# Operator Panels and Industrial PC

## FS244, FS184, FS153 and FS122 Operator Panels

### FS244, FS184, FS153 and FS122 Operator Panels (without Integrated iPC)

NUM has developed passive control panels that are designed for use with an external PC or NUM Industrial Box PC P1/P2.

Four different passive panel sizes are available: 12" (FS122), 15" (FS153), 18.5" (FS184) and 24" (FS244).

The passive panels FS122 are available with and without touch screen. Both versions have got 22 functional keys.

The passive panels FS153-FK (keyboard option F) and FS153-FQ (keyboard option Q) have the same appearance and dimensions as NUM's FS154i panels, but do not have an integrated PC.

The passive panels FS184 and FS244 could be used as landscape or vertical oriented projective, capacitive touch panel. The display quality makes the panels very legible, even in poorly-lit environments. Compact and very rugged, the panels are sealed (IP65) and suitable for use in severe industrial environments.

3

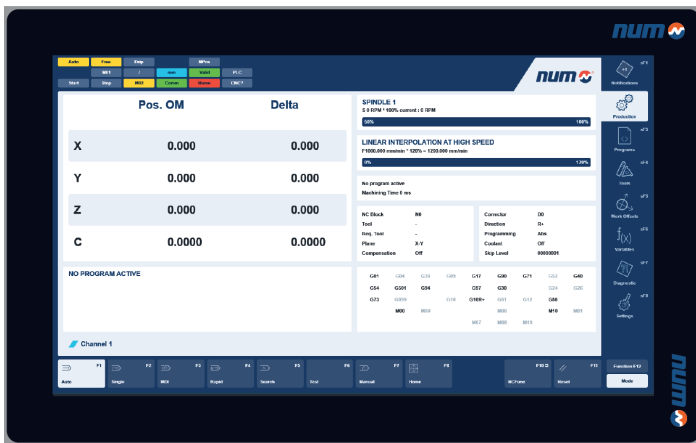

FS184, FS244

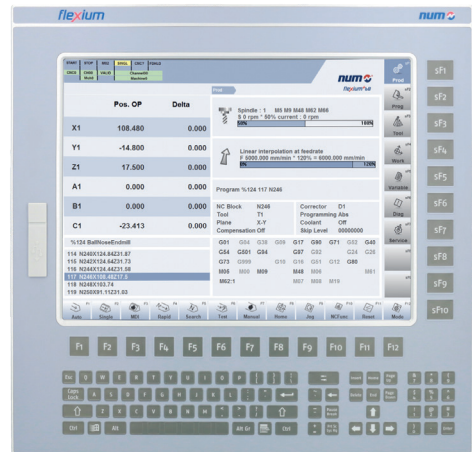

FS153-FQ

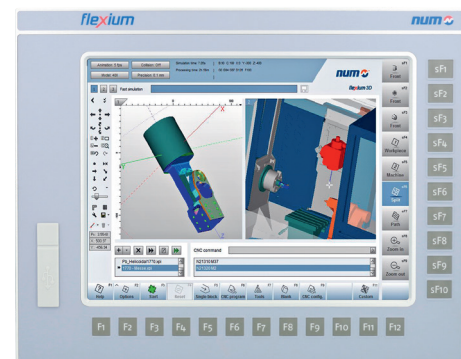

FS122

# Operator Panels and Industrial PC

## FS184 and FS244 Operator Panels without Integrated iPC

### FS184 and FS244 Operator Panels without Integrated iPC

FS184 and FS244 are, respectively, 18.5 inch and 24 inch operator panels without integrated iPC; the display, glass protected, integrates a projected capacitive multi-touch screen system.

They are durable, modern front end for machine control. They have an IP65 degree of protection at the front, and IP20 at the rear.

For these new operator panels, virtual key boards / machine panels are not yet available.

They can be mounted in landscape or portrait format.

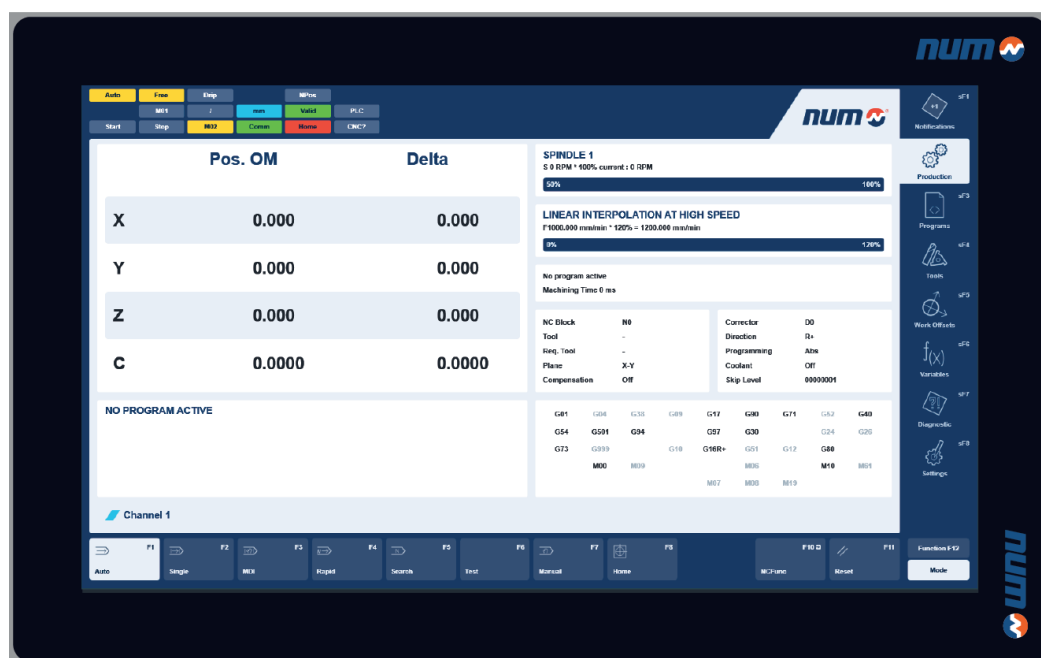



### FS184 and FS244 (without Integrated iPC) Technical Characteristics

		FXPC184CNNNN00	FXPCC244CNNNN00
Screen	User interface options	Projected capacitive touch screen with glass protection	
	Technology	18.5" TFT LCD (16.9 million colors)	24" TFT LCD (16.9 million colors)
	Resolution	1366 x 768	1920 x 1080
	Size	409.8 x 230.4 mm	531.3 x 298.8 mm
	Backlight	LED, Contr. 1000:1	LED, Contr. 5000:1
Communication Interfaces	USB	3 x USB 3.0 Type A / 1 x USB 3.0 Type B (rear)	
	DVI	1	
	VGA Connection	1	
	HDMI	1	
	Rated voltage	24VDC (+15%/-15%) SELV	
Power Supply	Protection against reverse polarity	Yes	
	Protection against over voltage	Yes	
	Potential insulation	No. (The 0V-pin of the PS is connected to the digital GND)	
	Power consumption	24 W typ., max. 48 W (2 A)	28 W typ., max. 60 W (2.5 A)
Ambient Conditions	Climatic conditions operation	5..45°C, 70% rel. air humidity, non-condensing	
	Climatic conditions storage	-20...60°C, 70% rel. air humidity, non-condensing	
	Climatic conditions transport	-20...60°C, 90% rel. air humidity, non-condensing	
Degree of Protection	Front	IP 65	
	Rear	IP 20	
Weight		5.3 kg	7.5 kg
Dimensions	W x H x D	488 x 309 x 51 mm	621.5 x 389 x 56 mm

#### FS184 (without Integrated iPC) Outlines Dimensions

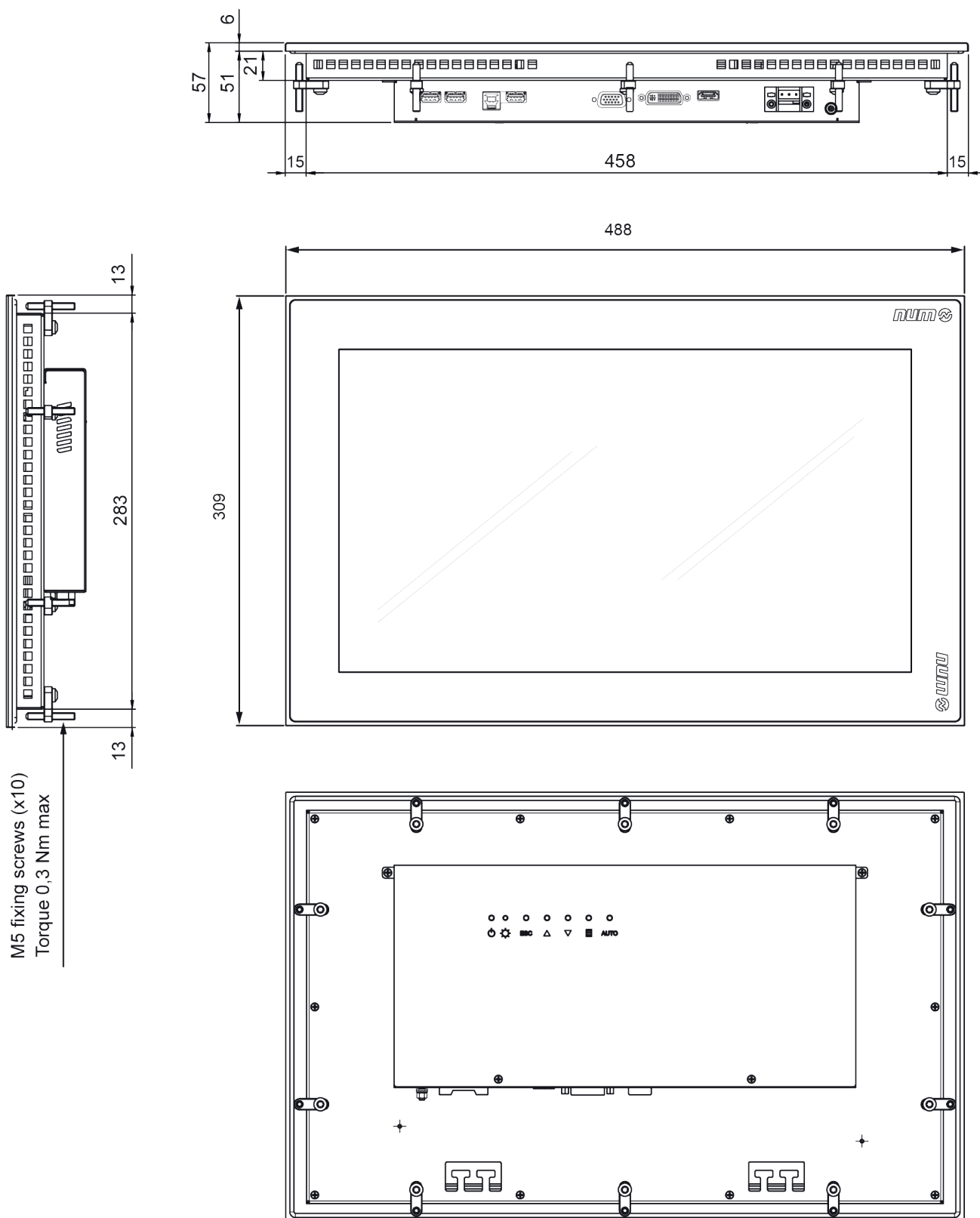

### FS184 (without Integrated iPC) Cut-out area

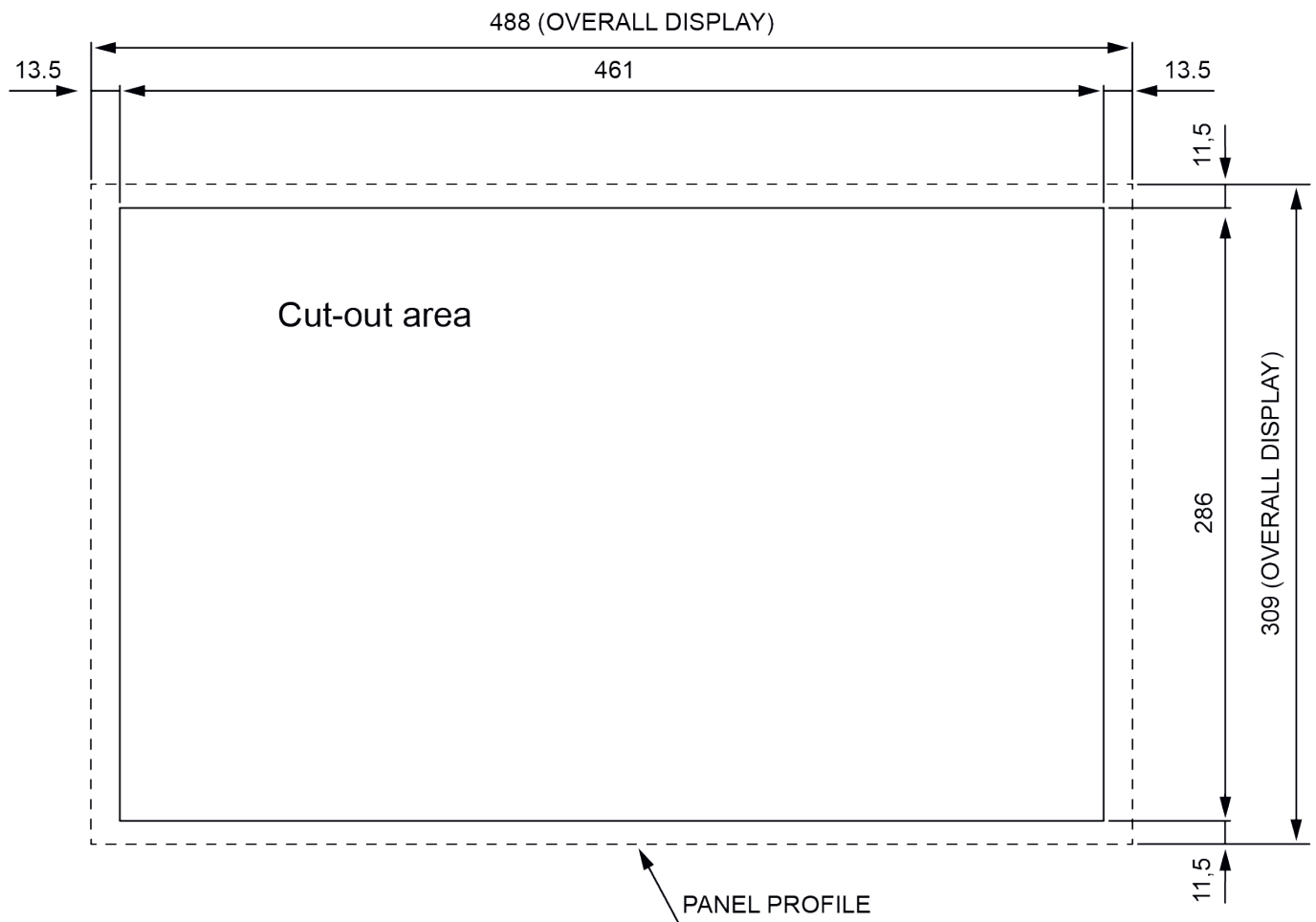

#### FS244 (without Integrated iPC) Outlines Dimensions

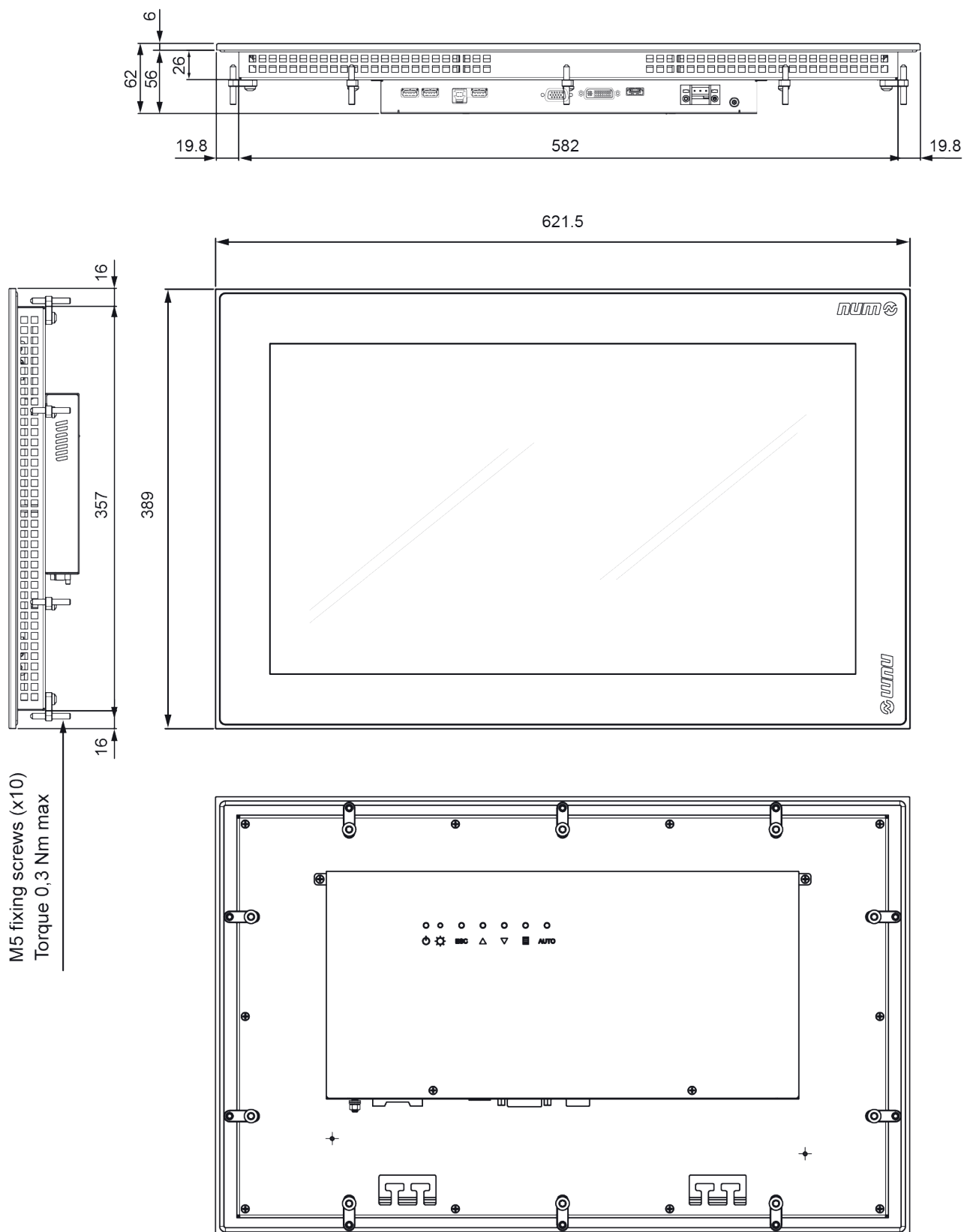



### FS244 (without Integrated iPC) Cut-out area

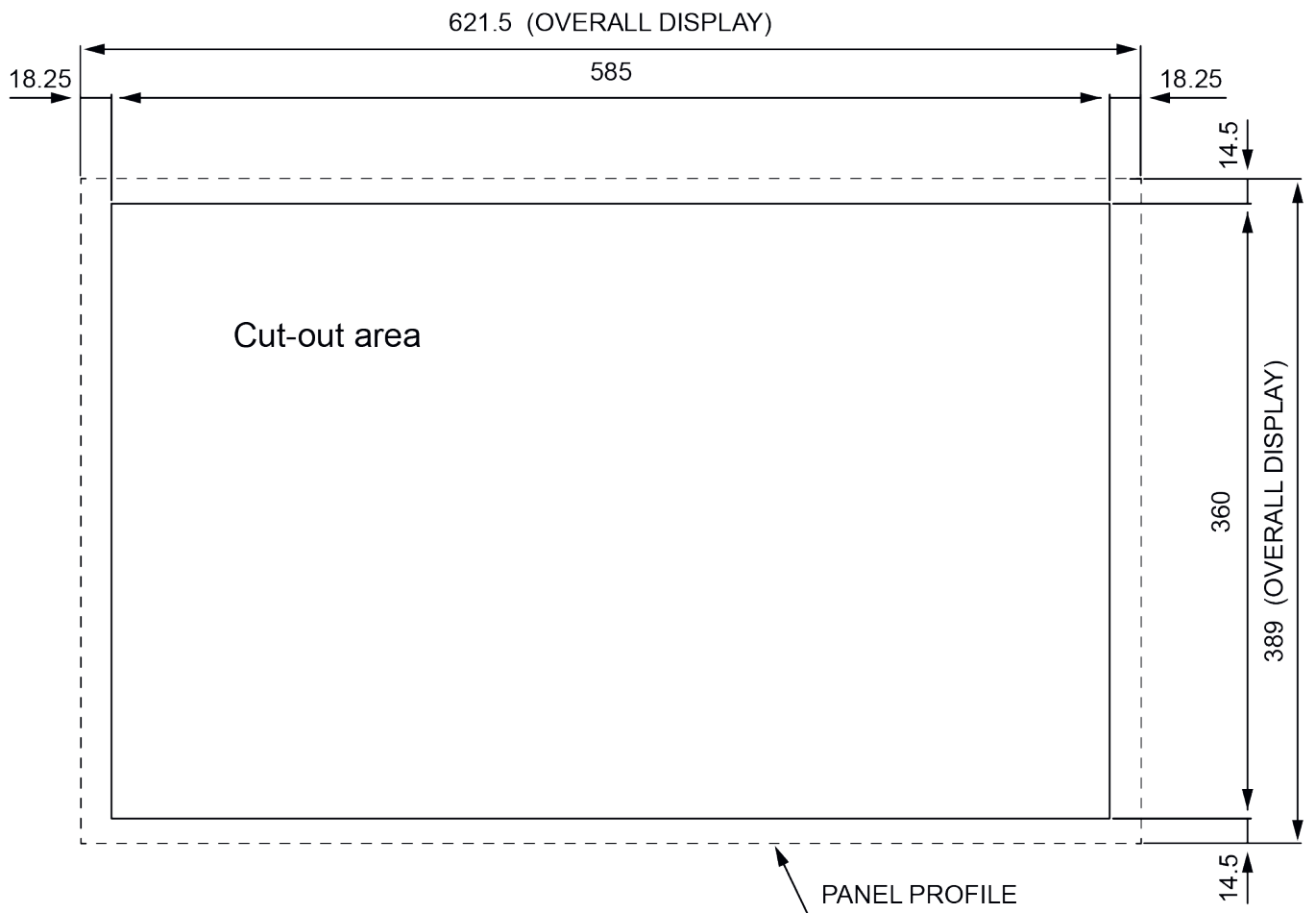

# Operator Panels and Industrial PC

FS184 and FS244 Operator Panels without Integrated iPC

Ordering Codes

## Operator Panel FS184 and FS244 Available Versions

Version	Ordering Codes
FS184 - TS	FXPC184CNNNNN00
FS244 - TS	FXPC244CNNNNN00

	FXPC	18	4	C	N	N	N	N	N	0	0
<b>Display Unit</b>											
• LCD 18.5"		18									
• LCD 24"		24									
<b>Panel/Mechanical Variant</b>											
• Fourth generation			4								
<b>Display Sensor</b>											
• Touch Screen projective capacitive				C							
<b>Keyboard Type</b>											
• No keyboard, No function keys					N						
<b>IPC Mother Board, Processor</b>											
• No iPC, just operator panel						N					
<b>Mass Memory Type</b>											
• No iPC, just operator panel							N				
<b>Option Board</b>											
• None								N			
<b>Fixed Value</b>											
									N		
<b>Operating System</b>											
• No iPC, just operator panel										0	
<b>Spare Number</b>											0

#### User Interface Options

3



Panel with 22 Function Keys

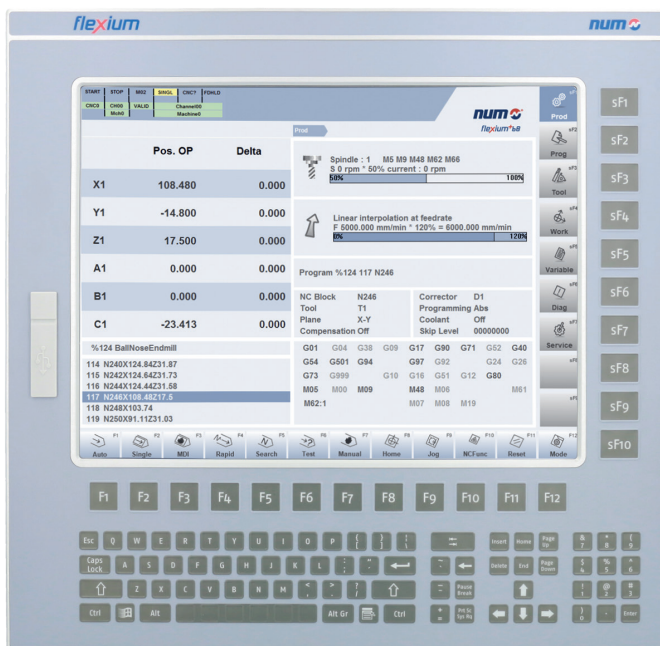

Panel with 22 Function Keys and QWERTY-Keyboard



### FS153 (without Integrated PC) Technical Characteristics

		<b>FXPC153xFNNNN00</b> <b>FXPC153NQNNNN00</b>
Screen	User interface options	Operator panel without integrated PC: <ul style="list-style-type: none"> <li>• 22 Function Keys</li> <li>• 22 Function Keys and Qwerty Keyboard</li> <li>• Touch Screen (resistive)</li> </ul>
	Technology	15" TFT LCD (16.9 million colors)
	Resolution	1024 x 768 from 60Hz to 75Hz
	Size	304 x 228 mm (12 x 9 inch)
	Backlight	LED, Contr. 700:1 (Typ)
Communication Interfaces	USB front	1 x USB Type A
	USB rear	2 x USB Type A (only 1 x USB Type A in case of touch version) + 1 x USB type B
	DVI interface	1
	VGA interface	1
Power Supply	Rated voltage	24 VDC (+15%/-15%) SELV
	Protection against reverse polarity	Yes
	Protection against over voltage	Yes
	Potential insulation	No, the 0V pin is connected to the digital GND
	Power consumption	ca. 28 W
Environmental Conditions	Climatic conditions operation	0..50°C , 70% relative air humidity, non-condensing
	Climatic conditions storage	-20...60°C, 70% relative air humidity, non-condensing
	Climatic conditions transport	-20...60°C, 90% rel. air humidity, non-condensing
Degree of Protection	Front	IP 65
	Rear	IP 20
	Pollution degree	2
Weight		ca. 5.3 kg Function Key version ca. 5.7 kg Full Qwerty version
Dimensions	W x H x D	410 x 330 (400) x 53.2 mm
Cooling Type		Fanless

#### Outlines FS153 (without Integrated PC)

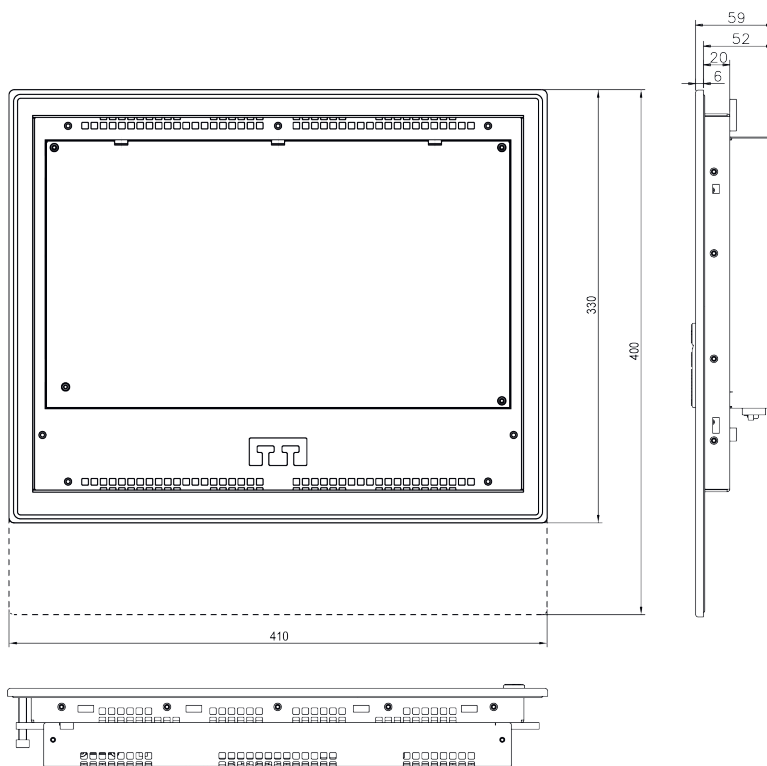

3

Dashed line FS153xQ version only

#### Operator Panel FS153 Cut-Out area

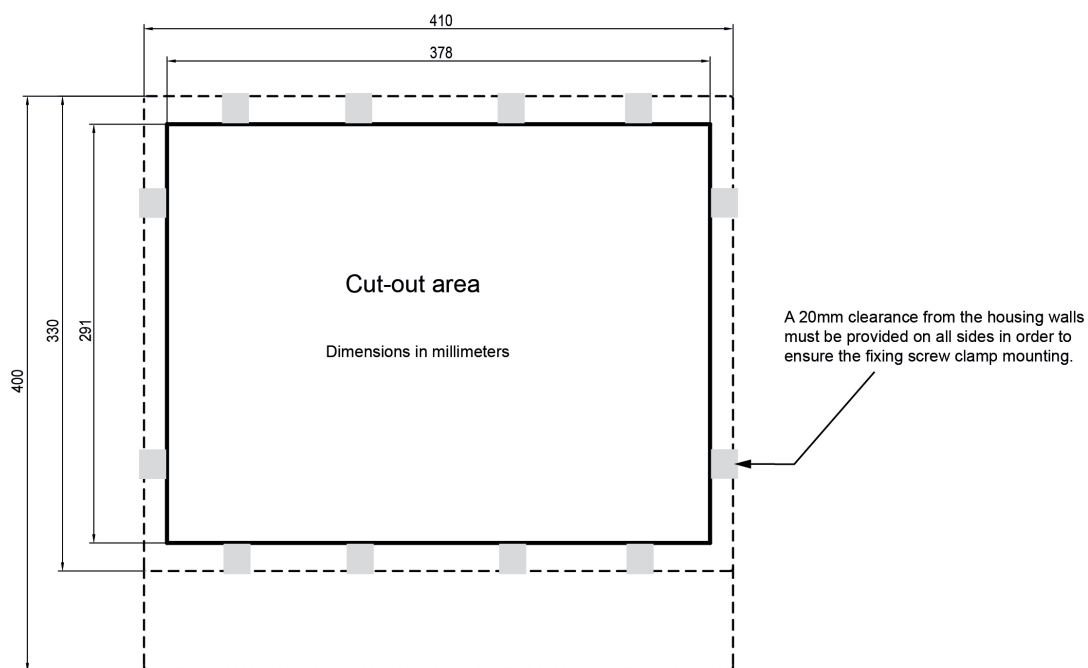

Dashed lines shows the panel dimensions

## FS153 Operator Panels

### Ordering Codes

#### FS153 Ordering Codes

The FS153 panels can be provided in two different versions and with two different fronts (function keys and function keys with QWERTY keyboard):

- FS153-FK: 15" Screen for PC-Panel with function keys
- FS153-FQ: 15" Screen for PC-Panel with function keys and QWERTY keyboard

FS153 Version	Ordering Codes
FS153-FK	FXPC153NFNNNN00
FS153-FK TS	FXPC153RFNNNN00
FS153-FQ	FXPC153NQNNNN00

	FXPC	15	3	R	F	N	N	N	N	0	0
<b>Display Unit</b>											
• LCD 15"		15									
<b>Panel/Mechanical Variant</b>											
• Third generation			3								
<b>Display Sensor</b>											
• Touch screen resistive				R							
• No touch Sensor				N							
<b>Keyboard Type</b>											
• 22 Function keys					F						
• 22 Function keys + Qwerty keyboard					Q						
<b>IPC Mother Board, Processor</b>											
• No IPC, just operator panel						N					
<b>Mass Memory Type</b>											
• No IPC, just operator panel							N				
<b>Option Board</b>											
• None								N			
<b>Fixed Value</b>										N	
<b>Operating System</b>											0
• No IPC, just operator panel											0
<b>Spare Number</b>											0

### User Interface Options

3

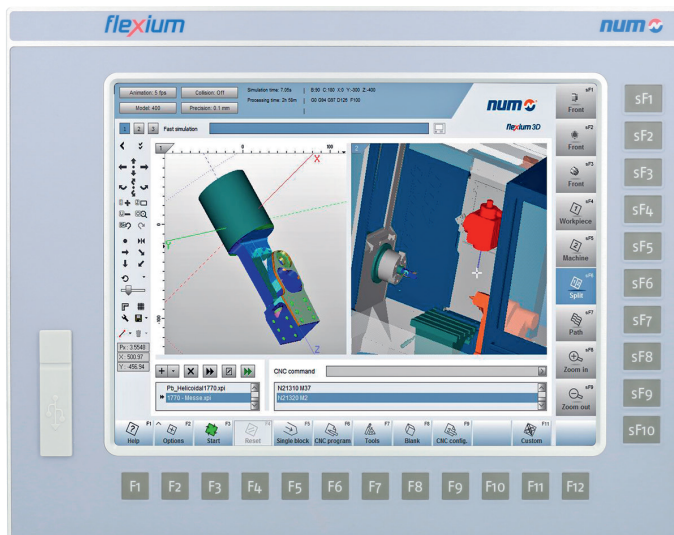

Panel with 22 Function Keys

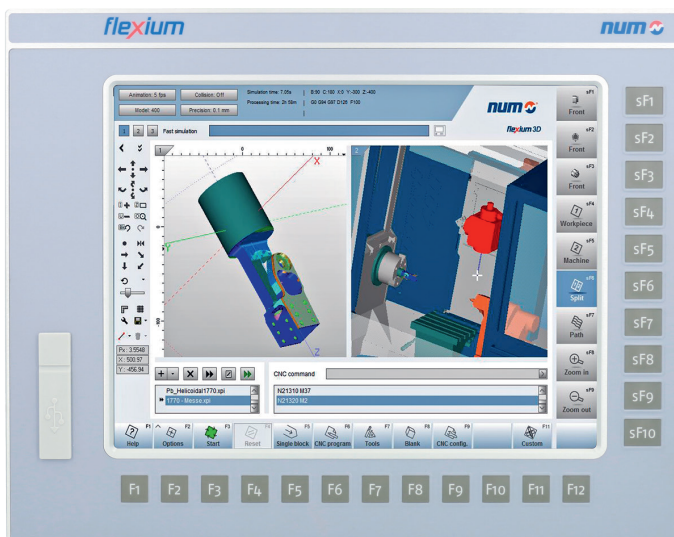

Panel with 22 Function Keys and Resistive Touch Screen





### FS122 Technical Characteristics

		<b>FXPC122xFNNNN00</b>
Screen	User interface options	22 Function Keys Resistive touch screen available as option
	Technology	12.1" LED
	Resolution	1024 x 768 on 60 Hz till 75 Hz
	Size	Diagonal 307 mm
	Contrast	Contr. 700:1
	Brightness	600 cd/m <sup>2</sup>
Communication Interfaces	USB front (1x)	V2.0 - 1.5/12/480 MBit/s USB Type A
	USB rear (3x)	V2.0 - 1.5/12/480 MBit/s 2 USB Type A + 1 USB type B (1)
	DVI interface	1
	VGA interface	1
Power Supply	Rated voltage	24 VDC SELV, safety extra low voltage. Protection class III
	Voltage range	24 VDC 20.4...28.8 VDC / rated
	Protection against reverse polarity	Yes
	Protection against over voltage	Yes
	Potential insulation	No. (The 0V-pin of the PS is connected to the digital GND)
Ambient Conditions	Power consumption	ca. 25 W. As point of reference, the 24V-power supply should be rated for 4A continuous load
	Climatic conditions operation	0...50 °C , 10...90 % relative air humidity, non-condensing
	Climatic conditions storage	-20...60 °C, 10...90 % relative air humidity, non-condensing
EMC	Climatic conditions transport	Class 2K3 EN50178 (reduced -20...60°C, 10...90% relative air humidity, non-condensing)
	EMC immunity	Industry EN 61000-6-2
Degree of Protection	EMC emission	Residential area EN 61000-6-3
	Front	IP 65
Weight	Rear	IP 20
		3.45 kg
Dimensions	W x H x D	347 x 276 x 63 mm
	Cut out	331 x 260 mm (+0/-1mm)

#### FS122 Outlines

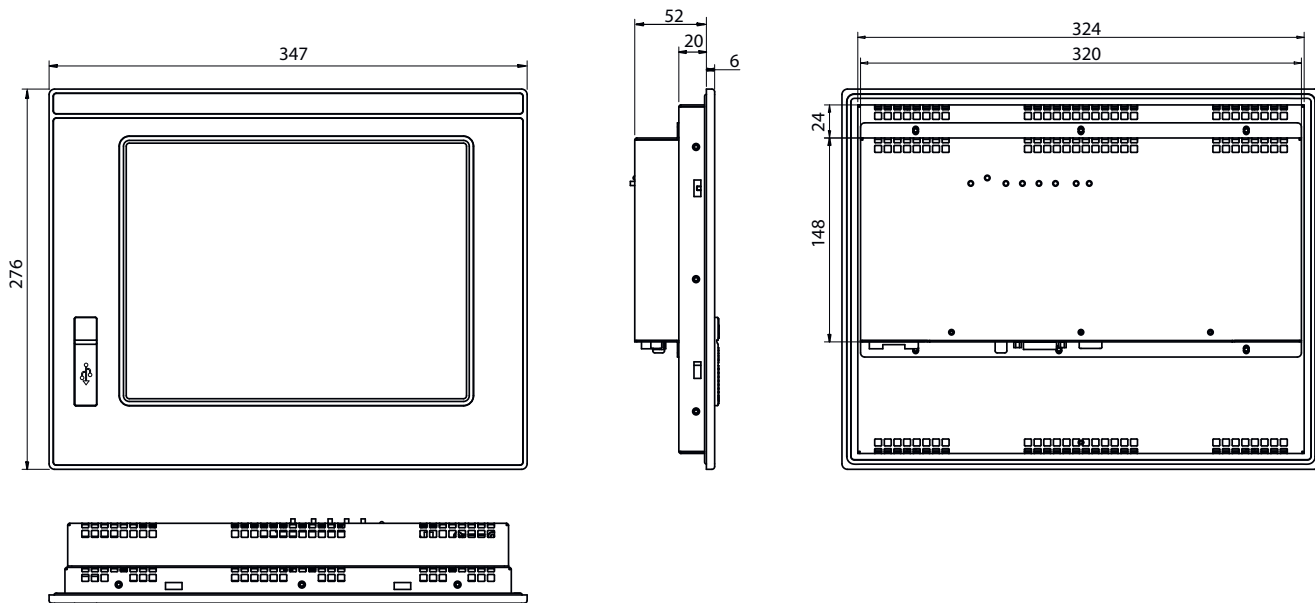

3

#### FS122 Cut-Out area

For FS122 a simple rectangle cut-out is needed (no holes); the cut-out has the following dimensions: 331 x 260 mm (+0/-1mm).

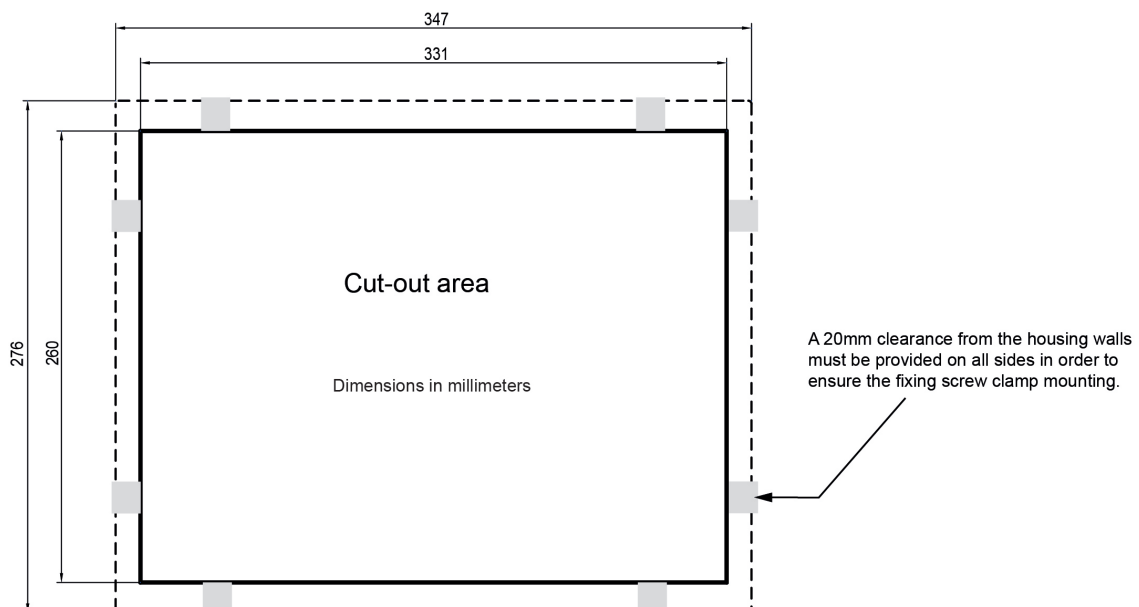

#### FS122 Ordering Codes

FS122 Version	Ordering Codes
FS122-FK-TS	FXPC122RFNNNN00
FS122-FK	FXPC122NFNNNN00

	FXPC	12	2	R	F	N	N	N	N	N	0	0
<b>Display Unit</b> • LCD 12"		12										
<b>Panel/Mechanical Variant</b> • Second generation			2									
<b>Display Sensor</b> • Touch screen resistive • No touch Sensor				R N								
<b>Keyboard Type</b> • 22 Function keys					F							
<b>IPC Mother Board, Processor</b> • No IPC, just operator panel						N						
<b>Mass Memory Type</b> • No IPC, just operator panel							N					
<b>Option Board</b> • No fieldbus, just operator panel								N				
<b>Fixed Value</b>									N			
<b>Operating System</b> • No IPC, just operator panel											0	
<b>Spare Number</b>												0

## Machine Panels

NUM offers 3 different machine panels typically used for manually controlling movement, production initiation and intervention during machining.

MP06, MP07 and MP08 machine panels include:

- 60 configurable buttons with LEDs
- 2 potentiometers for spindle speed and feed rate override. Possibility of replacement by selectors for MP06
- 1 Handwheel (as optional)
- 1 Emergency stop button (MP06 and MP07 only)
- 1 Three-position key switch
- 3 Dedicated buttons: Reset (white LED), Cycle Stop (Red LED), Cycle Start (green LED)
- USB connector (MP07 only)

MP06, MP07 and MP08 buttons actuate real mechanical switches and are connected to the FlexiumPro system by means of an EtherCAT fieldbus. Each button can be simply customized by inserting an icon in each key (that can be opened).

MP06 is designed to fit FS154i panel dimensions.

MP08 is designed to fit FS122 panel dimensions.

MP07 is designed to fit FS184i panel dimensions.

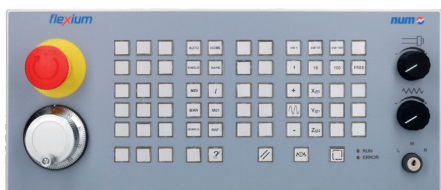

Machine Panel MP06



Machine Panel MP07



Machine Panel MP08

## MP06 Machine Panel

### MP06 Machine Panel

This panel is used for manually controlling movement, production initiation and intervention during machining. MP06 is designed to fit FS153 and FS154i panel dimensions.

MP06 includes:

- 60 configurable buttons with blue LEDs
- 2 Overrides potentiometers or selector for spindle speed and feed rate
- 1 Handwheel (as optional)
- 1 Emergency stop button
- 1 Three-position key switch
- 3 Dedicated buttons: Reset (white LED) Cycle Stop (Red LED), Cycle Start (green LED)
- 2 Dedicated LEDs for EtherCAT state: RUN and ERROR

MP06 is connected to the FlexiumPro system with EtherCAT.

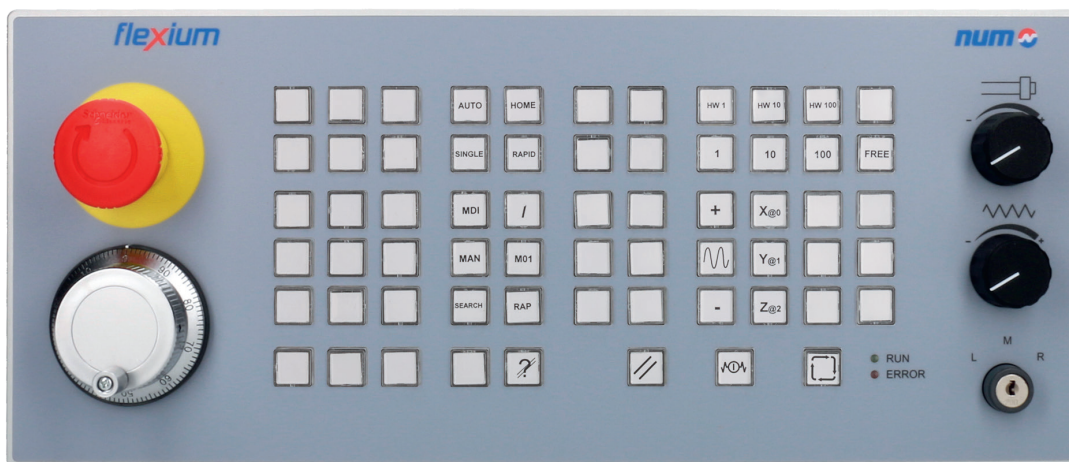



## MP06 Machine Panels Technical Characteristics

		FXHE02ARE1WE000	FXHE02ARE1HE000	FXHE02ARE2WE000	FXHE02ARE2HE000
Interfaces	Communication interface	Standard EtherCAT 2xRj45			
	Handwheel input	1 input for 5VDC handwheel with A & B push-pull signal			
	Key switch	1 key switch with 3 positions			
	Potentiometer	2 potentiometers 10 kOhm, 8 Bit resolution		Not present	
	Selector	Not present		2 switch selectors with 25 positions	
	Handwheel	Not present	Yes (100 Pulse per rev.)	Not present	Yes (100 Pulse per rev.)
	Emergency stop	1			
Press Buttons	Free configurable	60 buttons with mechanical switches with LEDs			
	Cycle start, cycle stop and reset	3 buttons with mechanical switches with LEDs			
Digital Inputs	Digital inputs	12 organized in 2 groups of terminals			
	Logic 0 / Logic 1	0 < 6 VDC (or < 3mA) 1 > 10 VDC up to 30 VDC (or > 5 mA up to 15 mA)			
Digital Outputs	Digital outputs	12 organized in 3 groups of terminals			
	Rated current	500 mA maximum per output			
	Protection	Short-circuit and permanent overloads (trip device)			
Power Supply	Rated voltage	24 VDC (from 18 VDC up to 30 VDC)			
	Protection against reverse polarity	Yes			
	Protection against over voltage	Yes			
	Potential isolation	No. (The 0V-pin of the PS is connected to the digital GND)			
	Power consumption	15 W max			
Ambient Conditions	Climatic conditions, operation	0..45°C, 70% rel. air humidity, non-condensing			
	Climatic conditions, storage & transport	-20...80°C, 70% rel. air humidity, non-condensing			
Degree of Protection	Front	IP 65			
	Rear	IP 00			
Weight		1.2 kg	1.4 kg	1.2 kg	1.4 kg
Dimensions	W x H x D	410 x 175 x 55 mm			
	Cut-out	380 x 145 mm (+0/-1mm)			

#### MP06 Machine Panel Outlines

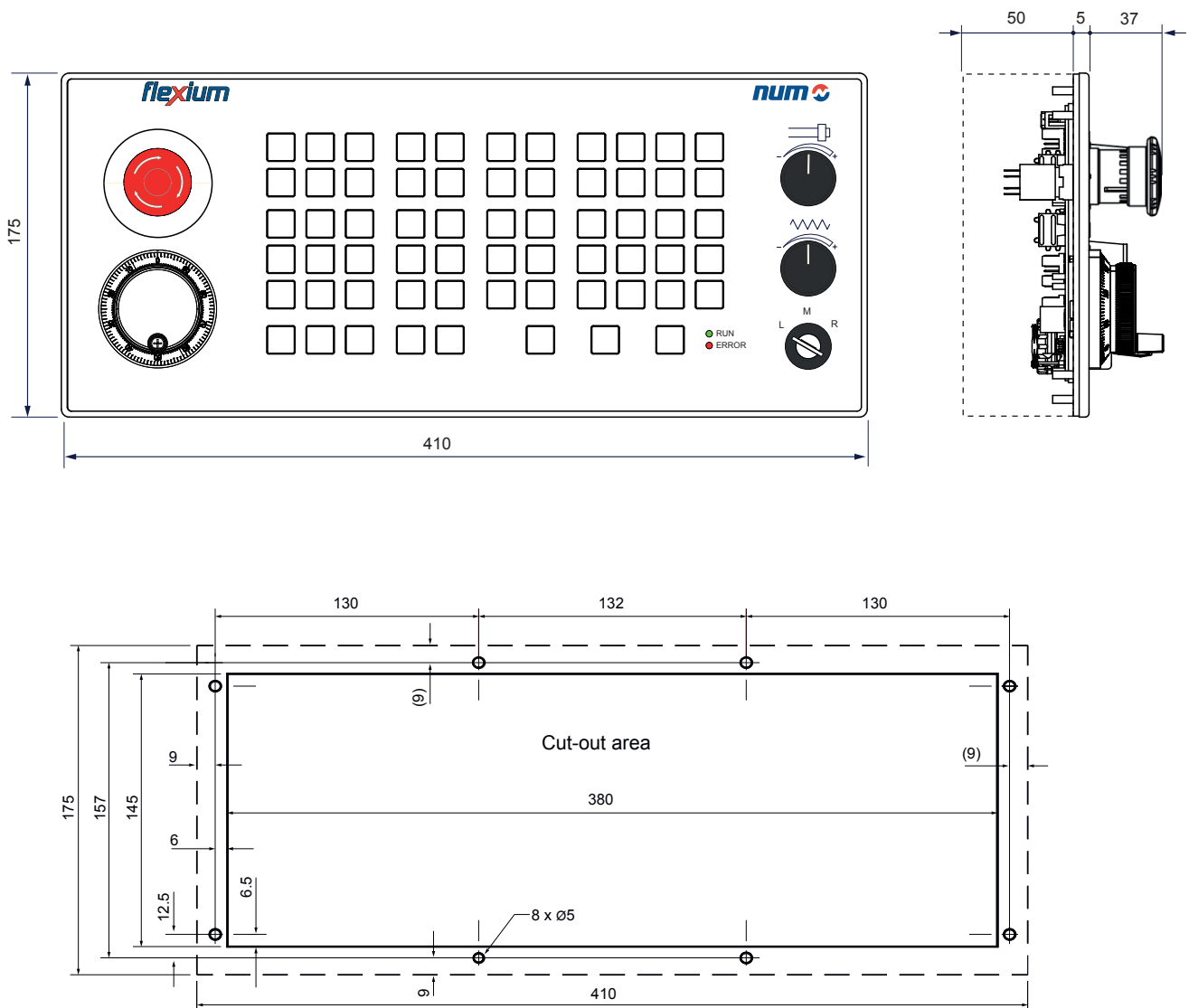



## MP06 Machine Panel

### Ordering Codes

#### MP06 Machine Panel

Machine Panel	Ordering Codes
Machine Panel MP06–W without handwheel and potentiometers	FXHE02ARE1WE000
Machine Panel MP06–H with handwheel and potentiometers	FXHE02ARE1HE000
Machine Panel MP06–W without handwheel and selectors	FXHE02ARE2WE000
Machine Panel MP06–H with handwheel and selectors	FXHE02ARE2HE000

## MP07 Machine Panel

### MP07 Machine Panel

This panel is used for manually controlling movement, production initiation, and intervention during machining.

MP07 is designed to fit FS184i panel dimensions.

MP07 includes:

- 60 configurable buttons with blue LEDs
- 2 Overrides potentiometers or selectors for spindle speed and feed rate
- 1 Handwheel (as optional)
- 1 Emergency stop button
- 1 Three-position key switch
- 3 Dedicated buttons: Reset (white LED), Cycle Stop (Red LED) and Cycle Start (green LED)
- 2 Dedicated LEDs for EtherCAT state: RUN and ERROR
- A USB extender
- Two holes (with caps) where the standard button can be mounted

MP07 is connected to the FlexiumPro system with EtherCAT.





### MP07 Machine Panels Technical Characteristics

		FXHE04ARE1HE100	FXHE04ARE2HE100	FXHE04ARE1WE100	FXHE04ARE2WE100
Interfaces	Communication interface	Standard EtherCAT 2xRj45			
	Handwheel input	1 input for 5VDC handwheel with A & B push-pull signal			
	Key switch	1 key switch with 3 positions			
	Potentiometer	2 potentiometers 10 kOhm, 8 Bit resolution		Not present	
	Selector	Not present		2 switch selectors with 25 positions	
	Handwheel	Not present	Yes (100 Pulse per rev.)	Not present	Yes (100 Pulse per rev.)
	Emergency stop	1			
Press Buttons	Free configurable	60 buttons with mechanical switches with LEDs			
	Cycle start, cycle stop and reset	3 buttons with mechanical switches with LEDs			
Digital Inputs	Digital inputs	12 organized in 2 groups of terminals			
	Logic 0 / Logic 1	0 < 6 VDC (or < 3mA) 1 > 10 VDC up to 30 VDC (or > 5 mA up to 15 mA)			
Digital Outputs	Digital outputs	12 organized in 3 groups of terminals			
	Rated current	500 mA maximum per output			
	Protection	Short-circuit and permanent overloads (trip device)			
Power Supply	Rated voltage	24 VDC (from 18 VDC up to 30 VDC)			
	Protection against reverse polarity	Yes			
	Protection against over voltage	Yes			
	Potential isolation	No. (The 0V-pin of the PS is connected to the digital GND)			
	Power consumption	15 W max			
Ambient Conditions	Climatic conditions, operation	0..45°C, 70% rel. air humidity, non-condensing			
	Climatic conditions, storage & transport	-20...80°C, 70% rel. air humidity, non-condensing			
Degree of Protection	Front	IP 65			
	Rear	IP 00			
Weight		1.3 kg	1.5 kg	1.3 kg	1.5 kg
Dimensions	W x H x D	488 x 175 x 55 mm			
	Cut-out	455 x 144 mm (+0/-1mm)			

#### MP07 Machine Panel Outlines

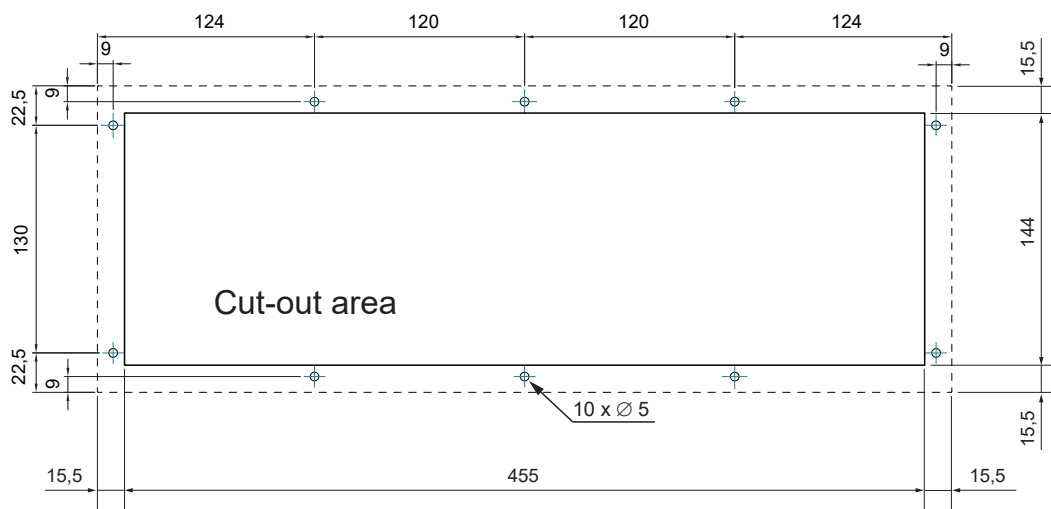
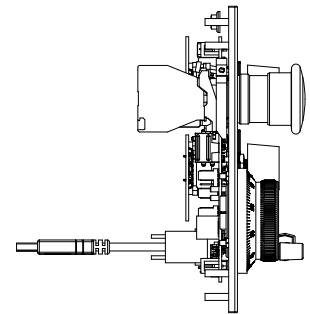
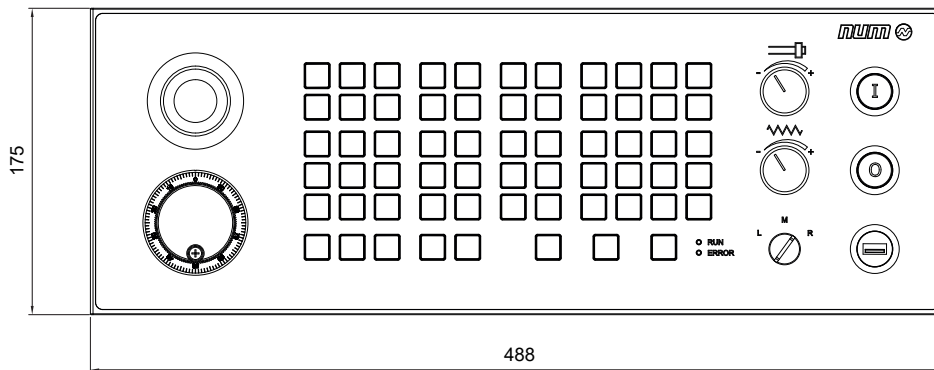

## MP07 Machine Panel

### Ordering Codes

#### MP07 Machine Panel

Machine Panel	Ordering Codes
MP07 with Handwheel, 2 Potentiometers, USB, and 2 Caps	FXHE04ARE1HE100
MP07 with Handwheel, 2 Selectors, USB, and 2 Caps	FXHE04ARE2HE100
MP07 with 2 Potentiometers, USB, and 2 Caps without Handwheel	FXHE04ARE1WE100
MP07 with 2 Selectors, USB, and 2 Caps without Handwheel	FXHE04ARE2WE100

## MP08 Machine Panel

### MP08 Machine Panel

MP08 has got identical characteristics as MP06, the only differences are:

- Smaller width dimension to fit FS122 panels
- E-STOP button and handwheel are not foreseen





### MP08 Machine Panels Technical Characteristics

		FXHE01ARD1WE000	FXHE01ARD2WE000
Interfaces	Communication interface	Standard EtherCAT 2x Rj45	
	Handwheel input	1 input for 5 VDC handwheel with A & B push-pull signal	
	Key switch	1 key switch with 3 positions	
	Potentiometer	2 potentiometers 10 kOhm, 8Bit resolution	Not present
	Selector	Not present	2 switch selectors with 25 positions
	Handwheel	Not present	
	Emergency stop	Not present	
Press Buttons	Free configurable	60 buttons with mechanical switches with LEDs	
	Cycle start, cycle stop and reset	3 buttons with mechanical switches with LEDs	
Digital Inputs	Digital inputs	12 organized in 2 groups of terminals	
	Logic 0 / Logic 1	0 < 6 VDC (or < 3mA) 1 > 10 VDC up to 30 VDC (or > 5 mA up to 15 mA)	
Digital Outputs	Digital outputs	12 organized in 3 groups of terminals	
	Rated current	500 mA maximum per output	
	Protection	Short-circuit and permanent overloads (trip device)	
Power Supply	Rated voltage	24 VDC (from 18 VDC up to 30 VDC)	
	Protection against reverse polarity	Yes	
	Protection against over voltage	Yes	
	Potential isolation	No. (The 0V-pin of the PS is connected to the digital GND)	
	Power consumption	15 W max	
Ambient Conditions	Climatic conditions, operation	0..45°C, 70% rel. air humidity, non-condensing	
	Climatic conditions, storage & transport	-20...80°C, 70% rel. air humidity, non-condensing	
Degree of Protection	Front	IP 65	
	Rear	IP 00	
Weight		1.2 kg	
Dimensions	W x H x D	347 x 175 x 55 mm	
	Cut-out	317 x 145 mm (+0/-1mm)	



#### MP08 Machine Panel

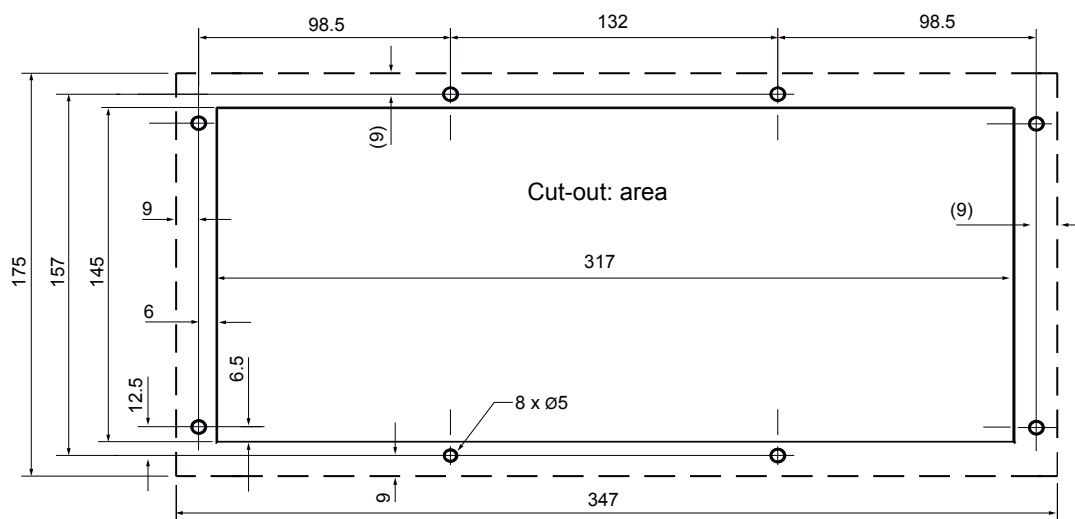
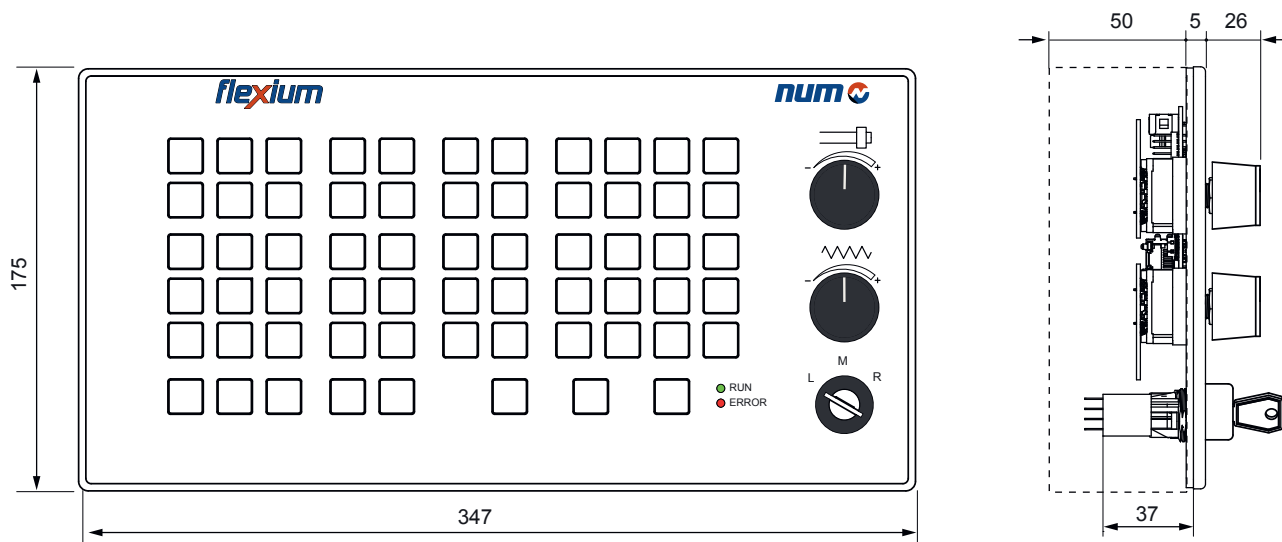

## MP08 Machine Panel

### Ordering Codes

#### MP08 Machine Panel

Machine Panel	Ordering Codes
MP08 with potentiometers	FXHE01ARD1WE000
MP08 with selectors	FXHE01ARD2WE000

3

#### MP06, MP07 and MP08 Ordering Codes

	FXHE	01	A	R	D	1	W	E	0	0	0
<b>Index / Mechanical variant</b>											
• MP08 (x FS122)		01									
• MP06 (x FS153)		02									
• MP07 (x FS184)		04									
<b>Integrated I/Os</b>											
• 12 digital inputs and 12 digital outputs			A								
<b>Keys number and technology</b>											
• 63 x keys with real switches				R							
<b>Safety functions</b>											
• 3 positions key switch (MP08 only)					D						
• E-STOP + 3 positions key switch (MP06 and MP07 only)					E						
<b>Override feedrate and spindle</b>											
• 2 potentiometers						1					
• 2 selectors with mechanical indexing						2					
<b>Handwheel</b>											
• None							W				
• Handwheel <sup>1</sup>							H				
<b>Connections Technology</b>											
• EtherCAT + wires for safety related devices								E			
<b>Spare Number</b>									0		
<b>Spare Number</b>										0	
<b>Spare Number</b>											0

<sup>1</sup> MP06 and MP07 only

### Vertical and horizontal keyboard for FS153 and FS154i

Add a horizontal keyboard in case of FS154i in touch screen version. Add a vertical keyboard (with a blanking plate) in case of using MP06 in conjunction with an FS153 or FS154i in touch screen version.

Machine Panel	Ordering Codes
Vertical USB keyboard including blanking plate	FXHE000248
Horizontal USB keyboard	FXHE000249



Horizontal USB Keyboard



Vertical USB Keyboard

### Application Example

FS154i, MP04, vertical Keyboard and plain cover board.

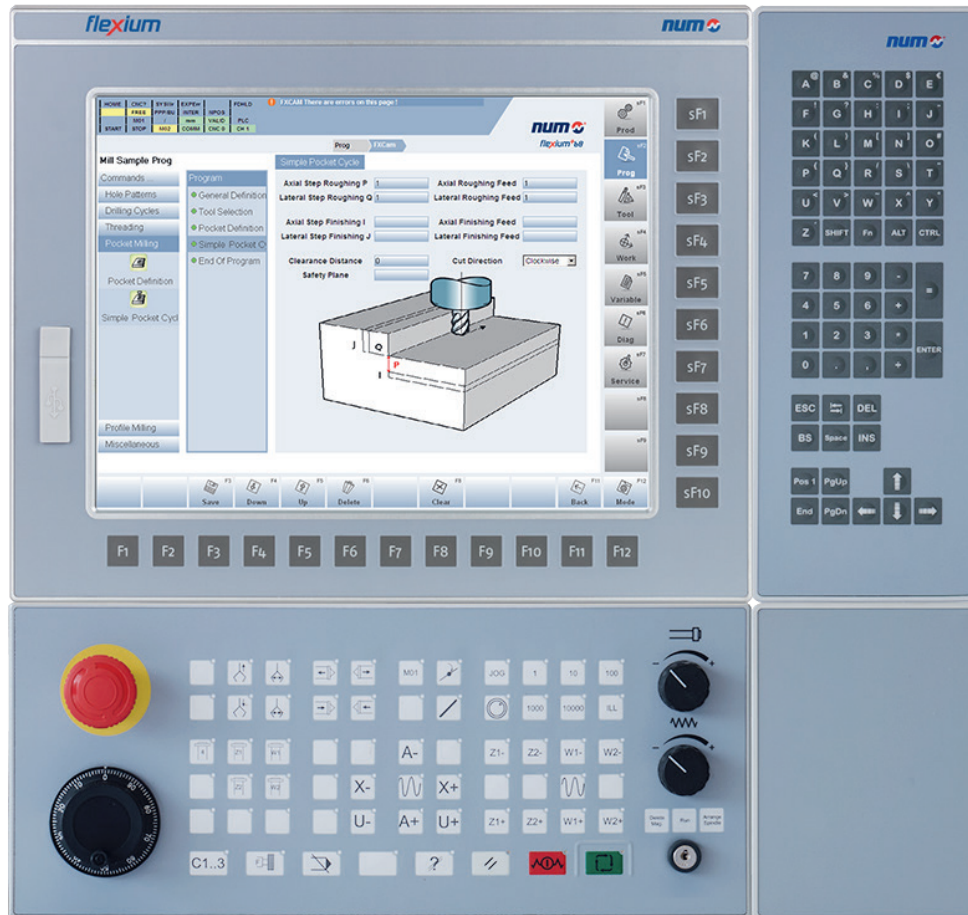

3

### NUM Industrial Box PC

NUM's Industrial Box PC provide a powerful and ergonomic platform for the FlexiumPro system, enabling you to interact with the machine in a simple and logical manner. Two performance levels are available: P1 and P2 both with quad-core processors.



### NUM Industrial Box PC P1 (FXPC004NN1SNR3A)

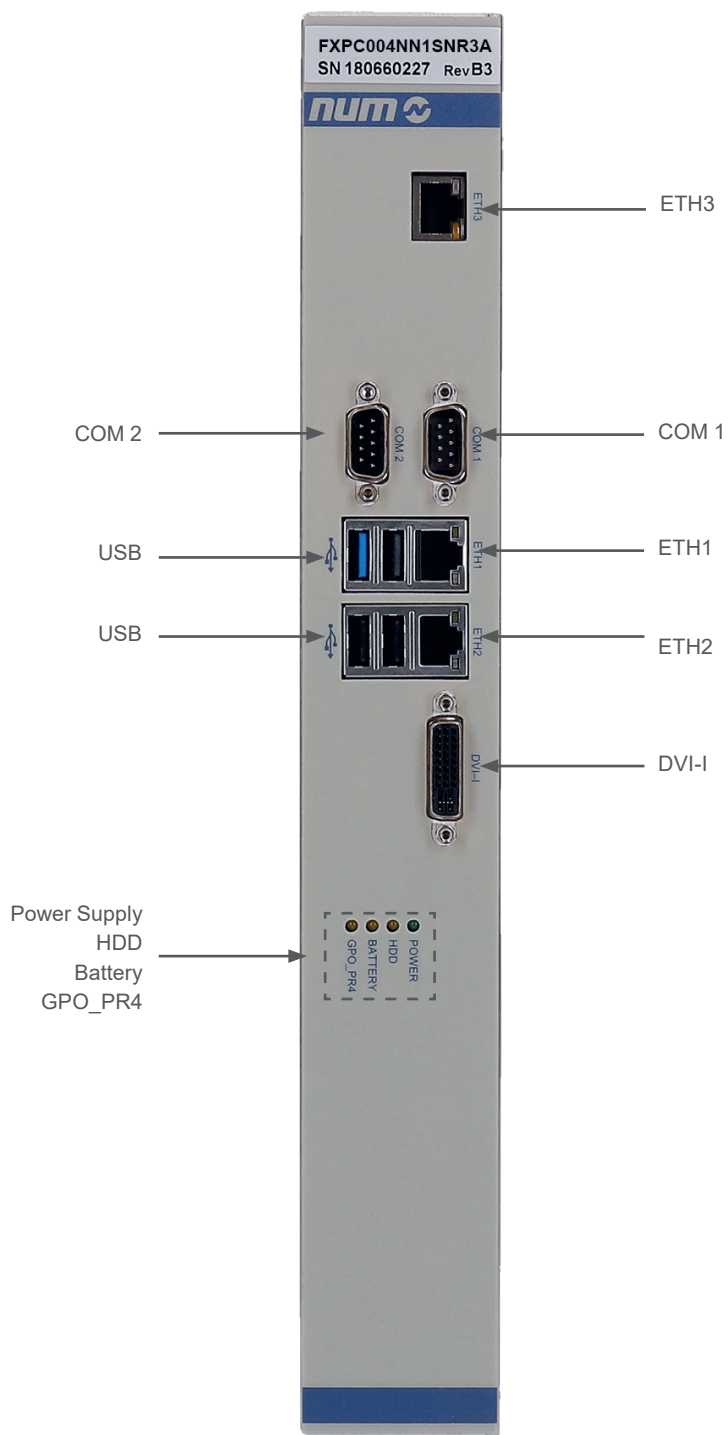

### NUM Industrial Box PC P2 (FXPC004NN2SNR20)

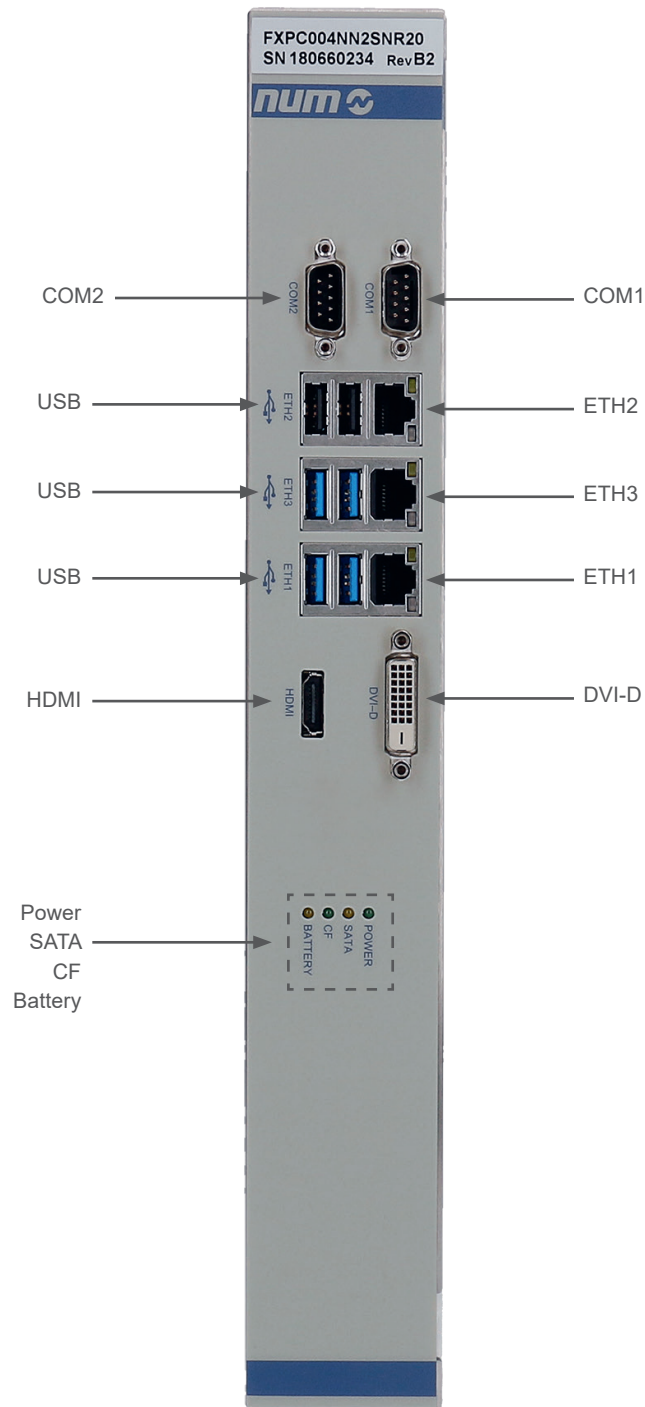





### NUM Industrial Box PC Technical Characteristics

		FXPC004NN1SxR3A (PC P1 G4A)	FXPC004NN2SxR20 (PC P2 G4)
Main PC Features	CPU	Intel® Celeron™ CPU J1900 @ 2GHz Quad Core	i5-6500TE 2.3GHz Quad Core
	RAM	2 GB	8 GB
	Mass storage	Industrial SSD 64 GB	Industrial SSD 64 GB
	Operating system	Windows 10 IoT Enterprise 64 bits	Windows 10 IoT Enterprise 64 bits
Communication Interfaces	Ethernet (ETH)	3 x Gigabit LAN / RTE	
	USB	3 x USB 2.0 Type A and 1 x USB 3.0 Type A	2 x USB 2.0 Type A and 4 x USB 3.0 Type A
	COM	2	2
	PS2	0	
	VGA	0	0
	DVI interface	1 DVI-I	1 DVI-D
	HDMI	No	1
Power Supply	Rated voltage	24 VDC (+15%/-15%) 2.1A	24 VDC (+15%/-15%) / 4A
	Protection fuse	Yes. Internal fuse 2A/250V	
	Power consumption	typ. 21 W max. 50 W (2.1 A)	typ. 48 W max. 96 W (4A)
Ambient Conditions	Climatic conditions operation	0...45°C, 70% rel. air humidity, non-condensing	
	Climatic conditions storage	-20...60°C, 70% rel. air humidity, non-condensing	
	Environmental conditions installation	Requires protection to at least IP54	
	Climatic conditions transport	-20...60°C, 10...90% rel. Air humidity, noncondensing	
Degree of Protection	IP20		
Pollution Degree	2		
Cooling Type	Fan-less		Internal (with fan)
Weight	ca. 2.4 kg		ca. 2.5 kg
Dimensions	W x H x D	50 x 355 (410) x 206 mm (Please refer to the next pages)	

### NUM Industrial Box PC P1 Outlines (FXPC004NN1HxR10)

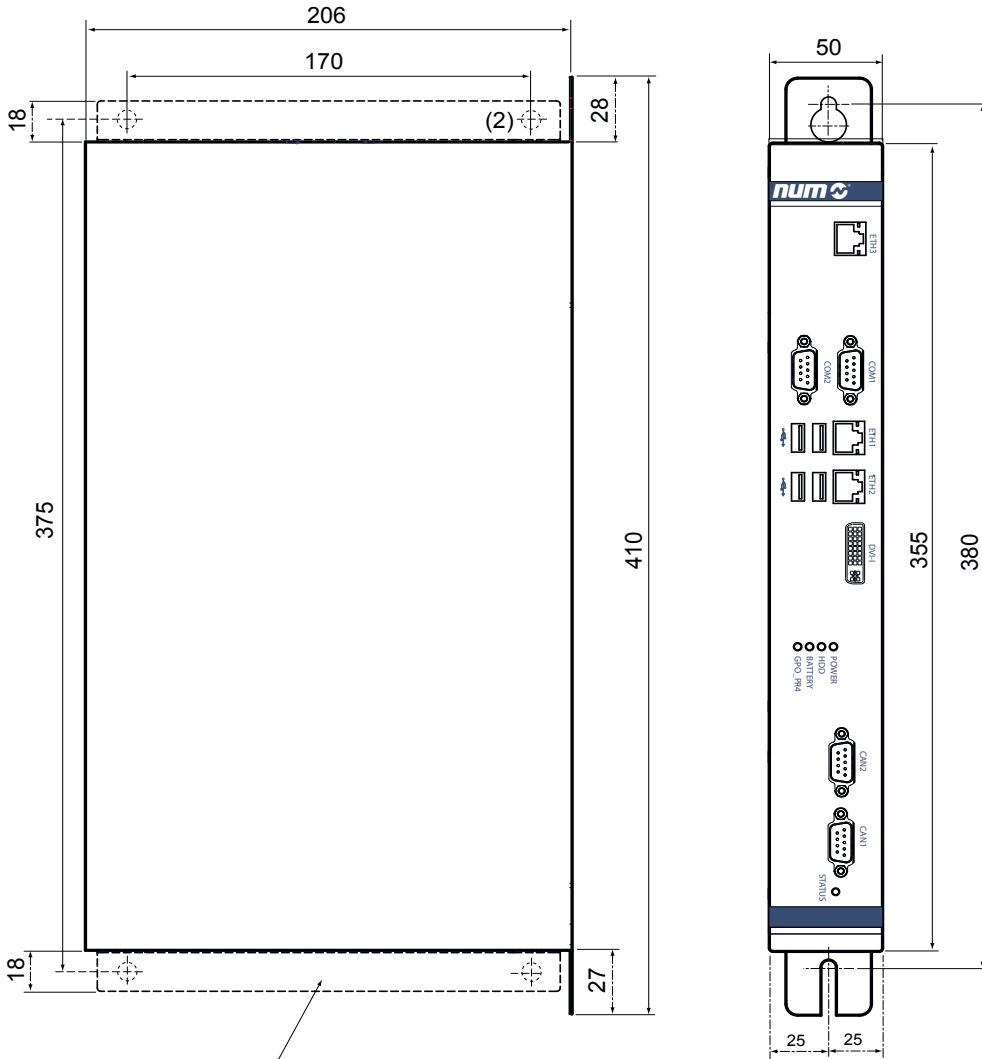
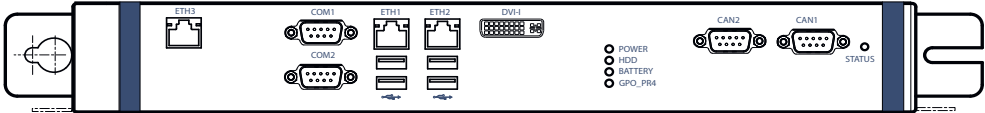
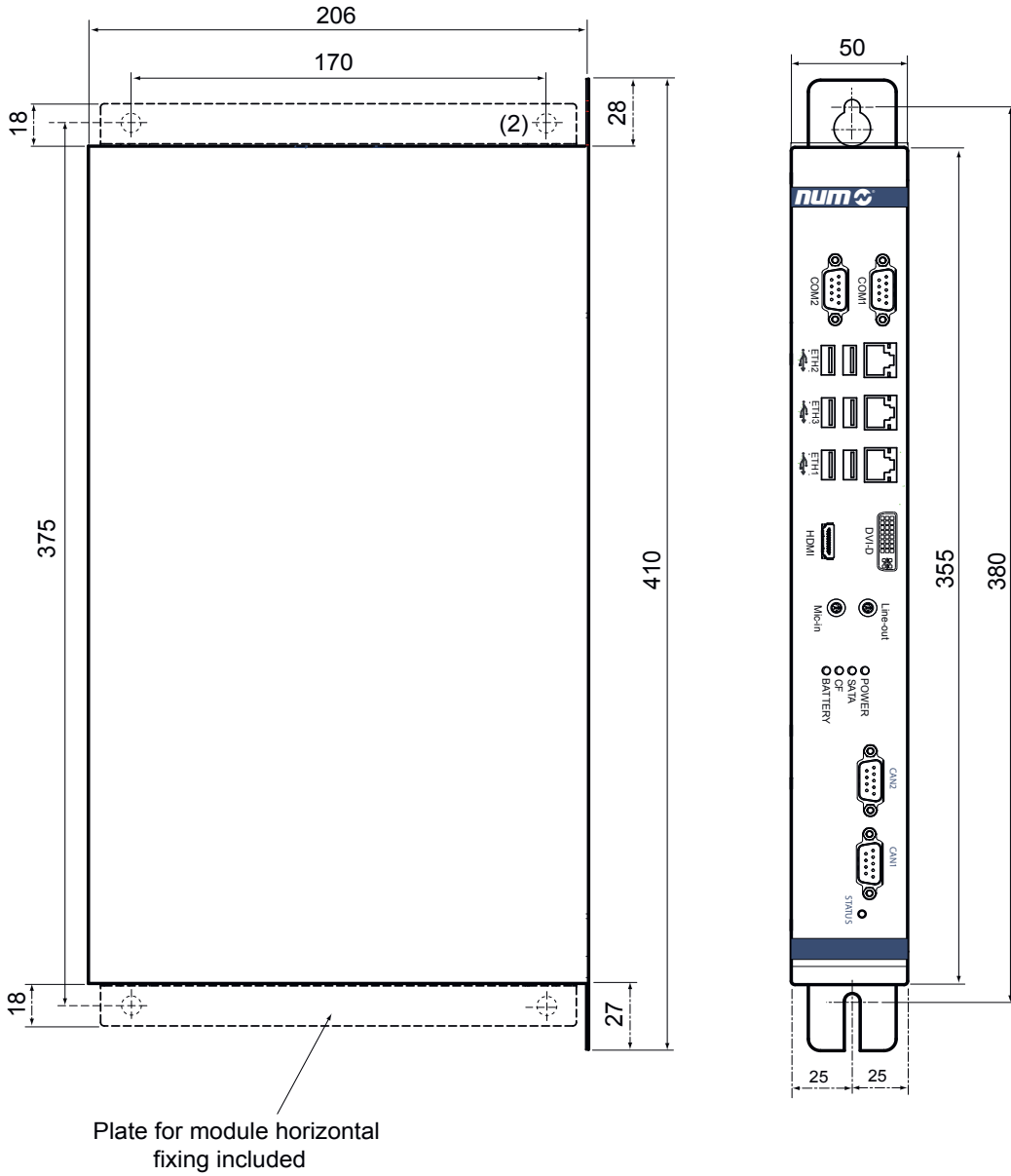

Plate for module horizontal fixing included

#### Module horizontal fixing



## NUM Industrial Box PC P2 Outlines (FXPC004NN2SxR20)



3

### Module horizontal fixing

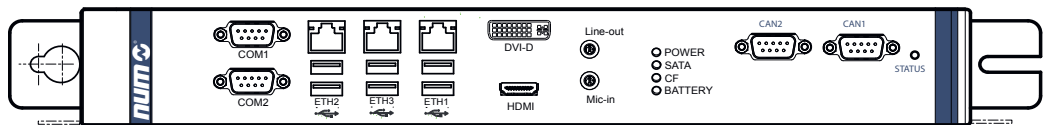

# Operator Panels and Industrial PC

## Industrial Box PC

### Ordering Codes

#### NUM Industrial Box PC Ordering Codes

Box PC Version	Ordering Codes
Box PC P2 G4 SSD	FXPC004NN2SNR20
Box PC P1 G4A SSD	FXPC004NN1SNR3A

	FXPC	00	4	N	N	1	S	N	R	1	0
<b>Display Unit</b>											
• Industrial Box PC		00									
<b>Panel/Mechanical Variant</b>											
• Fourth generation			4								
<b>Display Sensor</b>											
• No touch sensor, just Box PC				N							
<b>Keyboard Type</b>											
• No keyboard, just Box PC					N						
<b>IPC Mother Board, Processor</b>											
• Performance level P1						1					
• Performance level P2						2					
<b>Mass Memory Type</b>											
• SSD (Solid State Disc)							S				
<b>Option Board</b>											
• None								N			
<b>Fixed value</b>										R	
<b>Operating System</b>											
• Windows 10 kernel 64 bits for P1 G4A											3
• Windows 10 kernel 64 bits for P2 G4											2
<b>Versions</b>											
• P1 G4A											A
• P2 G4											0

## HBA-X Portable Handwheel

### HBA-X Portable Handwheel

The HBA-X portable handwheel for FlexiumPro provides a number of operation functions:

- Axis selection
- Hand mode and speed selection
- Forward/backward movement and speed override
- Handwheel
- 3 step acknowledge button (Enabling Device “dead-man’s button”)
- Connection to the system for FlexiumPro 6, 8 and 68 via cable and I/O modules

Connection to the FlexiumPro system can be made in two different ways:

- HBA-Xc (5V) FXHE181121  
can be connected by means of EtherCAT and the terminal CTMT5101
- HBA-Xd (24V) FXHE181122  
can be connected by means of EtherCAT and the terminal CTMT5151



### HBA-X Portable Handwheel Description



S1	Selector switch (12 position axis selection)
S2	Selector switch (8 position incremental selection and rate multiplier)
S3	3 stage acknowledge button Enabling Device (dead-man's button)
S4	Push button (negative)
S5	Push button (fast)
S6	Push button (positive)
S7	Handwheel
Cable	HBA-X cable + plug connector (23 pins M) together with a 23-pin F connector socket



### HBA-X Portable Handwheel Technical Characteristics

Handwheel	<ul style="list-style-type: none"> <li>• Impulse per revolution: 100</li> <li>• Supply voltage: 5 VDC <math>\pm</math> 5% for HBA-Xc / 24 VDC <math>\pm</math> 5% for HBA-Xd</li> <li>• Output circuit: 5 VDC or 24 VDC</li> </ul>
Push Button	<ul style="list-style-type: none"> <li>• Control element: 3 single closure</li> <li>• Switching voltage max: 30 VDC</li> <li>• Switching current max: 100mA</li> <li>• Switching power max: 1 W</li> </ul>
Acknowledge Button 3-Step	<ul style="list-style-type: none"> <li>• Control element: 1 double closure</li> <li>• Switching voltage max: 30 VDC</li> <li>• Switching current max: 1mA</li> <li>• Switching power max: 0.25 W</li> </ul>
Connection <sup>1,2</sup>	<ul style="list-style-type: none"> <li>• 23-pin connector</li> <li>• Cable 5 m</li> </ul>
Housing	<ul style="list-style-type: none"> <li>• Material: Plastic (polycarbonate)</li> <li>• Colour: Grey RAL 7040</li> <li>• Starting current: 250mA @ 24V</li> <li>• Power consumption: 3.12 W (typ) = 130mA @ 24V</li> <li>• Electrical insulation: No</li> </ul>
Overall Dimensions (L, H, W)	160 x 85 x 67 mm
Weight	Approx. 1.3 kg
Temperature	<ul style="list-style-type: none"> <li>• Operating temperature: 0 to +50°C</li> <li>• Transport and storage temperature: -20° to +50°C</li> </ul>
Relative Humidity	<ul style="list-style-type: none"> <li>• Operating: Max 95% non-condensing</li> <li>• Transport: Max 95% non-condensing</li> </ul>
Operating Altitude	Max 3000 m
Degree of Protection	IP65

<sup>1</sup> Different OEM handwheel locations may require an additional FXHE181310 socket for connection purposes

<sup>2</sup> Standard cable length is:  
5 m for straight cable

Maximum distance from CNC is 40 m

#### HBA-X Portable Handwheel Outlines

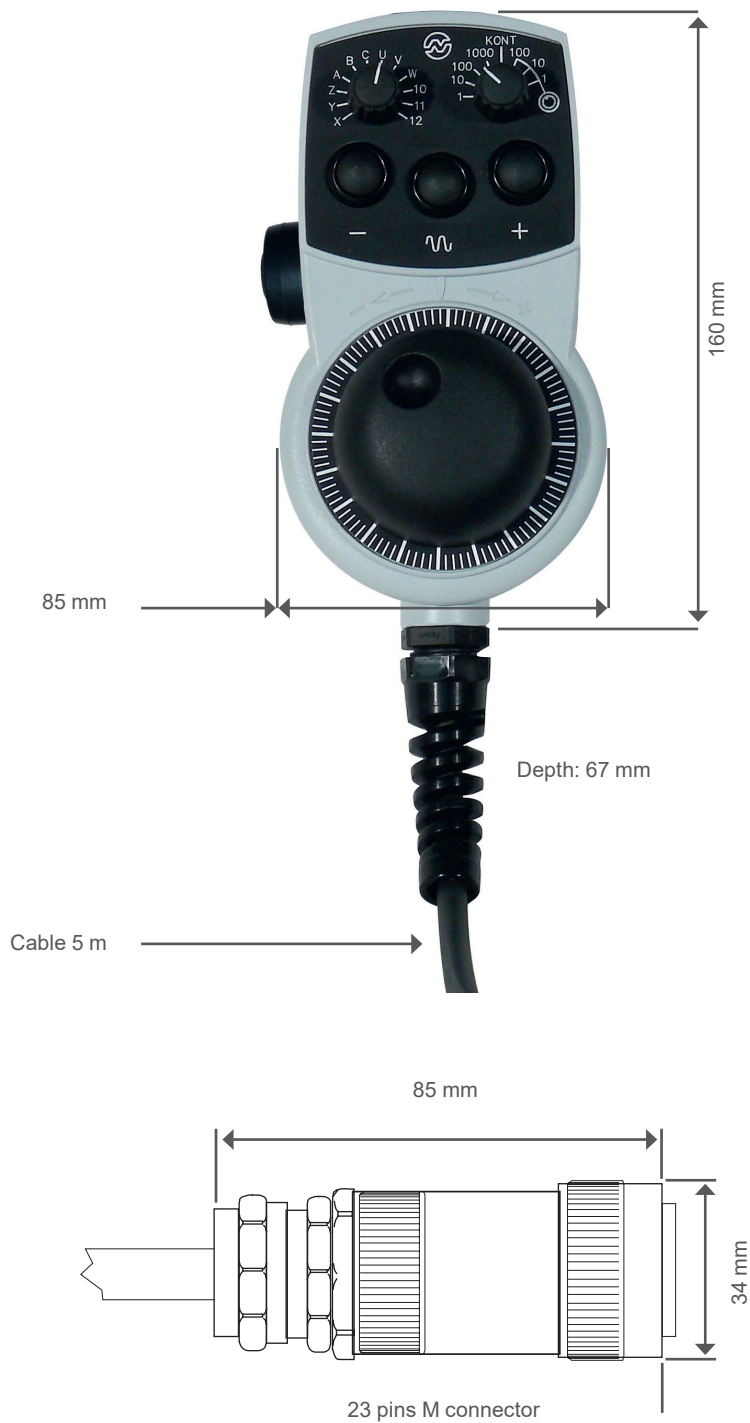



## HBA-X Portable Handwheel

### Ordering Codes

#### Portable Handwheel HBA-X Ordering Codes

---

XBA Version	Ordering Codes
HBA-Xc (5V)	FXHE181121
HBA-Xd (24V)	FXHE181122

### FlexiumPro RTK

FlexiumPro RTK is the heart of a system, with a Multicore ARM architecture and hard Real Time Operating System it integrates a powerful PLC, IEC 61131-3 compliance, and the NUM NCK.

By means of two EtherCAT ports, I/O terminals, Safe PLC and Safe I/Os and drives are connected.

PLC application, part programs, machine configuration, calibrations, etc., are all safely saved on a removable  $\mu$ SD card – and to secure shutdown processes, the NUM FlexiumPro RTK (Real Time Kernel) integrates a super-capacitor, which keeps the system alive for the time needed to save all data in the case of hard power off

Interfaces:

- 2 x analogue output (12 bits)
- 2 x analogue input (12 bits)
- 4 x fast input for probing
- 4 x fast opt-isolated output
- 1 x CANopen

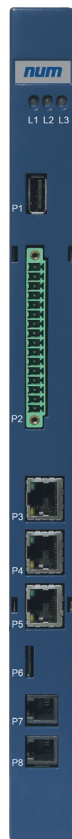

RTK front view



RTK top view

### Module Description

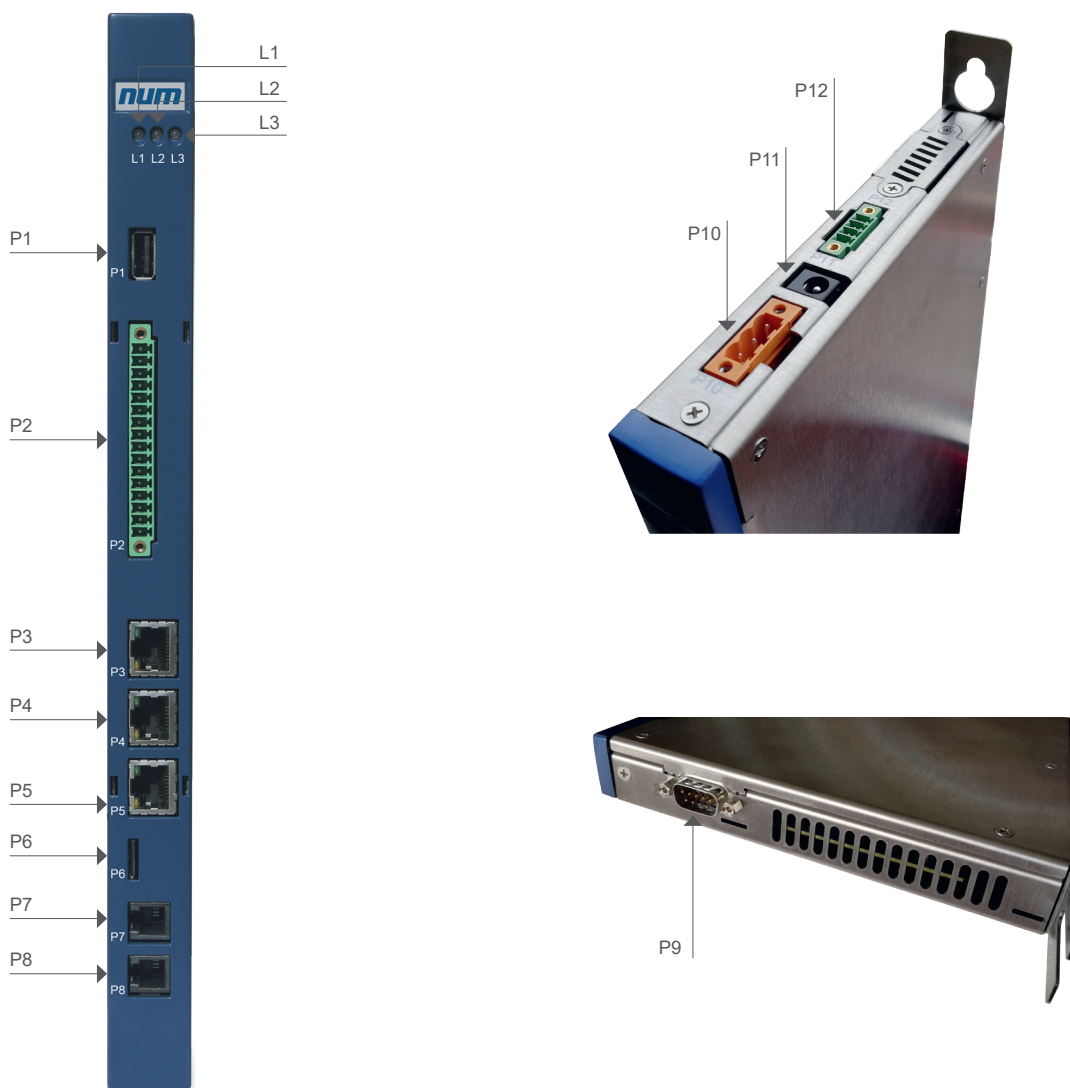

Connector	Description
L1, L2, L3	L1 = Power supply present, L2 = RTK Signaling, L3 = PLC Signaling
P1	USB 2.0
P2	24V digital I/O and +/-10V analog I/O connector
P3	PLC EtherCAT
P4	NUM DrivePro bus connection
P5	Company Network
P6	SD-Card
P7	RS-232 PLC Service Port
P8	RS-232 RTK Service Port
P9	CAN-Bus Connection
P10	24VDC (-20% / +10%) Input
P11	Power supply Jack (optional) (+5VDC 0% / +5% alternative to +24VDC supply)
P12	Watchdog Relay

### General Characteristics

FlexiumPro RTK		
Power Supply	Rated voltage	24 VDC -20% / +10%
	Power consumption	10W
Analog Inputs	2 analog inputs available	
	Input impedance	20kΩ
	Resolution	12 bits
	Input voltage range	-10V / +10V
Analog Outputs	2 analog outputs available	
	Output voltage range	-10V / +10V
	Minimum load	2kΩ
	Resolution	12 bits
Digital Inputs (probing inputs)	4 digital input available	
	Rated voltage	24 VDC
	Voltage limits	0V to 30 V
	Maximum current	6mA per input
	Operating voltage ranges	Low-level: < 5V (current < 6mA) High-level: >18V <30 V (current < 6mA)
	Reverse voltage withstand	30 VDC permanent
	Response time	100µs
	Sampling period	>= CNC-Cycle Time
	Logic	Positive (current sink)
	Protection	Complying with: IEC 62000-4-5, IEC 61000-4-4, IEC 61000-4-6
Outputs	4 digital output available	
	Nominal voltage	24 VDC +- 20% (external power supply)
	Voltage range	0V - 24VDC (+20%)
	Rated voltage	24 VDC (external power supply)
	Rated current	500 mA per output
	Protection per output	
	Overload Protection	internal
Ambient Conditions	Operating temperature range	0°C to 40°C
	Storage temperature range	-25°C to 70°C
	Relative humidity non condensing	max 75%
Protection Class		IP 20
Weight		1.2Kg
Dimensions	W x H x D	25 x 310 (365) x 160 mm

### RTK Overall Dimensions

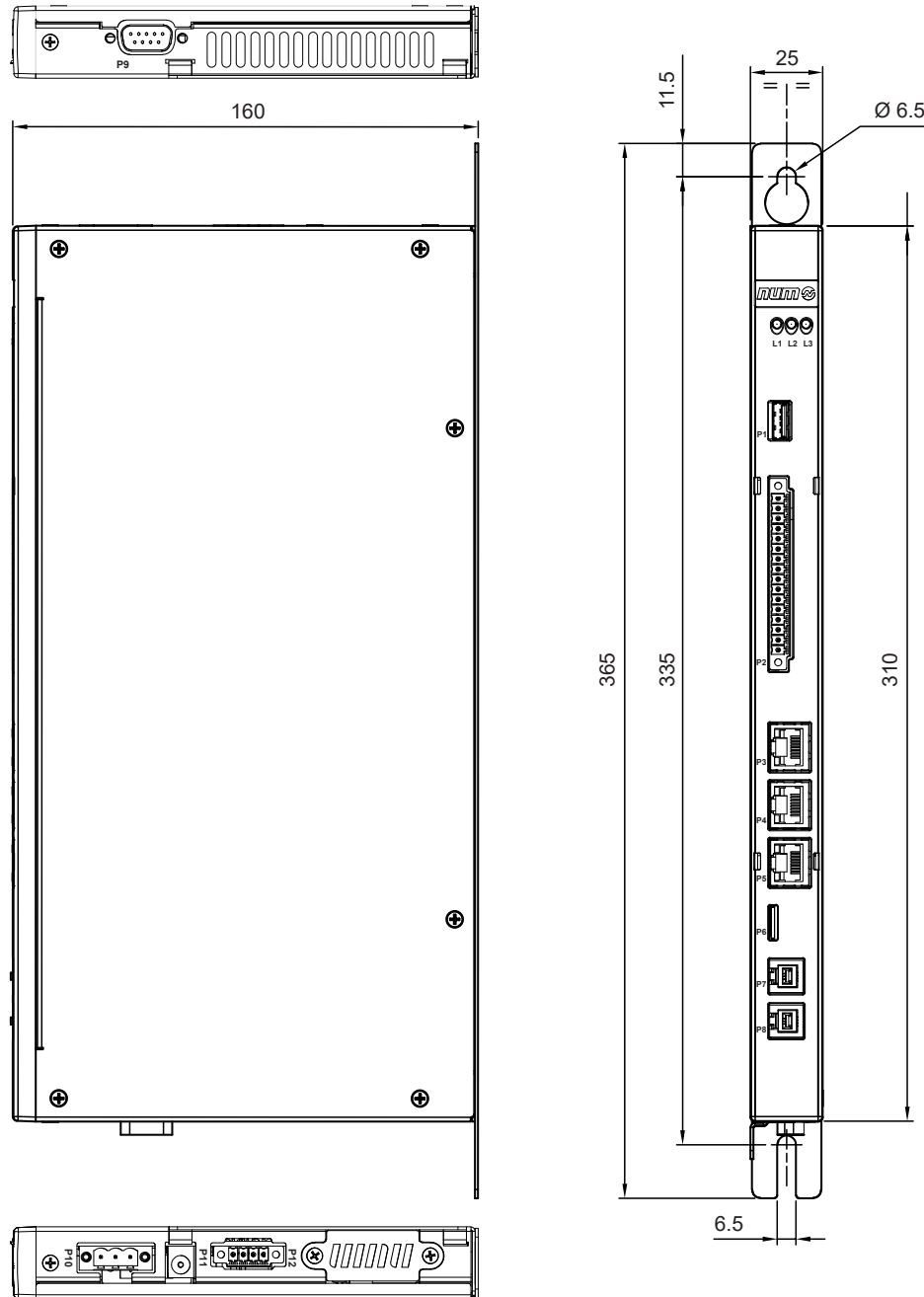

### RTK Ordering Code

FlexiumPro RTK does not require an order code. It is included in the FlexiumPro 6, FlexiumPro 8 and FlexiumPro 68 platform.



### CTMP6900 - NUMSafe PLC

The NUMSafe PLC controls the Safety PLC program and is connected in the same manner as any other EtherCAT terminal.

The CTMP6900 meets the requirements of IEC 61508 SIL 3 and EN 954 Cat. 4, DIN EN ISO 13849-1:2006 (Cat 4, PL e), NRTL, UL508, UL1998 and UL991.

The NUMSafe PLC has the typical design of an EtherCAT terminal.

For NUMSafe PLC the EtherCAT Safe PLC Option FPSW282305 is required.

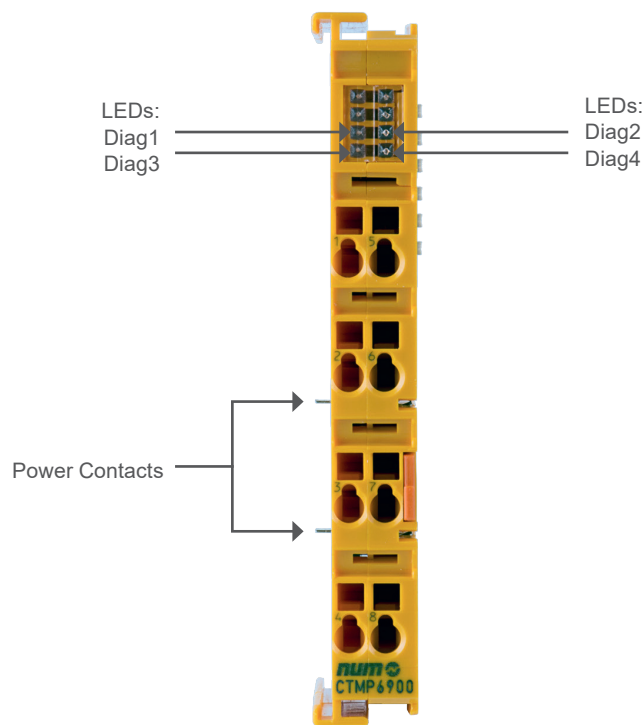



## CTMP6900 - Technical Characteristics

Product Name	CTMP6900
Number of Inputs	0
Number of Outputs	0
Status Display	4 diagnostic LEDs
Minimum Cycle Time	Approx. 500µs
Fault Response Time	≤ watchdog times
Watchdog Time	Min. 1ms, max. 60000ms
Input Process Image	Dynamic according to the NUMSafe configuration in "CODESYS Safety for EtherCAT Safety Module" programming system
Output Process Image	Dynamic according to the NUMSafe configuration in "CODESYS Safety for EtherCAT Safety Module" programming system
CTMP6900 Supply Voltage	From NUM EtherCAT Gateway CTMG1100
Current Consumption from the E-Bus	Approx. 188mA
Power Dissipation of the Terminal	Typically 1 W
Dimensions (W x H x D)	12 x 100 x 68 mm
Weight	Approx. 50 g
Permissible Ambient Temperature (Operation)	0°C to +55°C
Permissible Ambient Temperature (Transport / Storage)	-25°C to +70°C
Permissible Air Humidity	5% to 95%, non-condensing
Permissible Air Pressure (Operation / Storage / Transport)	750 hPa to 1100 hPa
Climate Class According to EN 60721-3-3	3K3
Permissible Contamination Level	Contamination level 2
Unacceptable Operating Conditions	NUMSafe terminals must not be used under the following operating conditions: <ul style="list-style-type: none"> <li>• under the influence of ionizing radiation</li> <li>• in corrosive environments</li> <li>• in an environment that leads to unacceptable soiling of the EtherCAT terminal</li> </ul>
Vibration / Shock Resistance	Conforms to EN 60068-2-6 / EN 60068-2-27, EN 60068-2-29
EMC Immunity / Emission	Conforms to EN 61000-6-2 / EN 61000-6-4
Shocks	15 g with pulse duration 11 ms in all three axes
Protection Class	IP20
Permitted Operating Environment	Control cabinet or terminal box with minimum protection class IP54 according to IEC 60529
Permissible Installation Position	Please refer to M00032 manual
Approvals	CE, cULus, ATEX

# NUMSafe PLC and Safe I/Os

CTMP6900 - NUMSafe PLC  
Outlines and Ordering Code



## CTMP6900 - Outlines

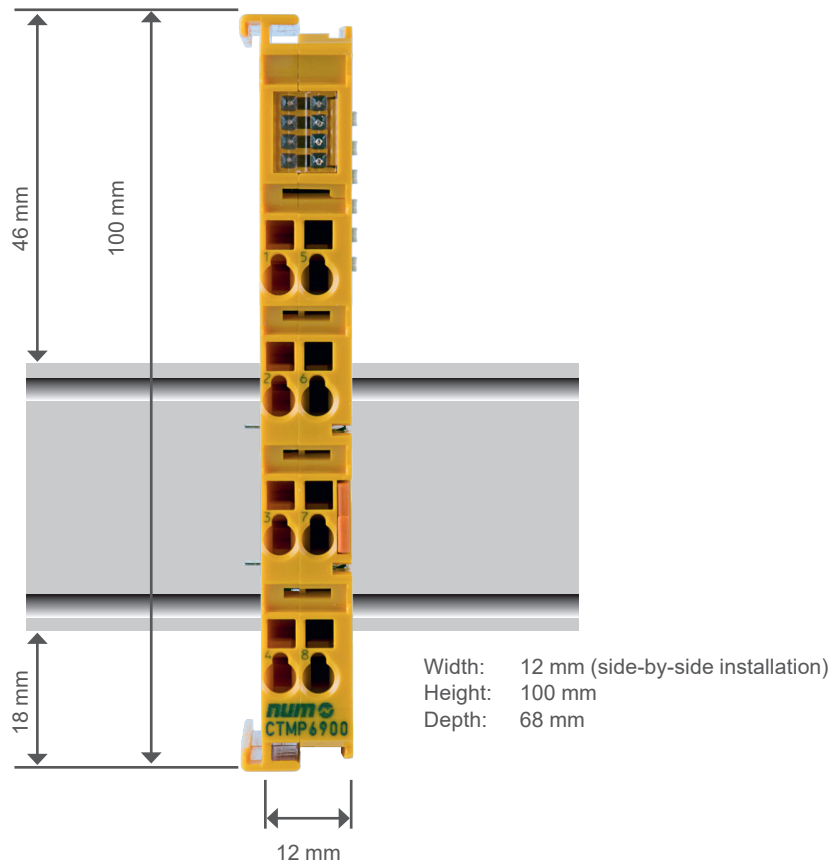

## CTMP6900 - Ordering Code

Product	Ordering Codes
NUMSafe PLC	CTMP6900





### CTMS1904 - NUMSafe Digital Inputs Terminal

The CTMS1904 is a digital input terminal, with floating contacts for 24 VDC.

The EtherCAT terminal has 4 fail-safe inputs.

With two-channel connection, the CTMS1904 meets the requirements of IEC 61508 SIL 3, EN 954, Cat 4, DIN EN ISO 13849-1:2006 (Cat 4, PL e), NRTL, UL508, UL1998 and UL991.

The NUMSafe Digital Inputs Terminal has the typical design of an EtherCAT terminal.

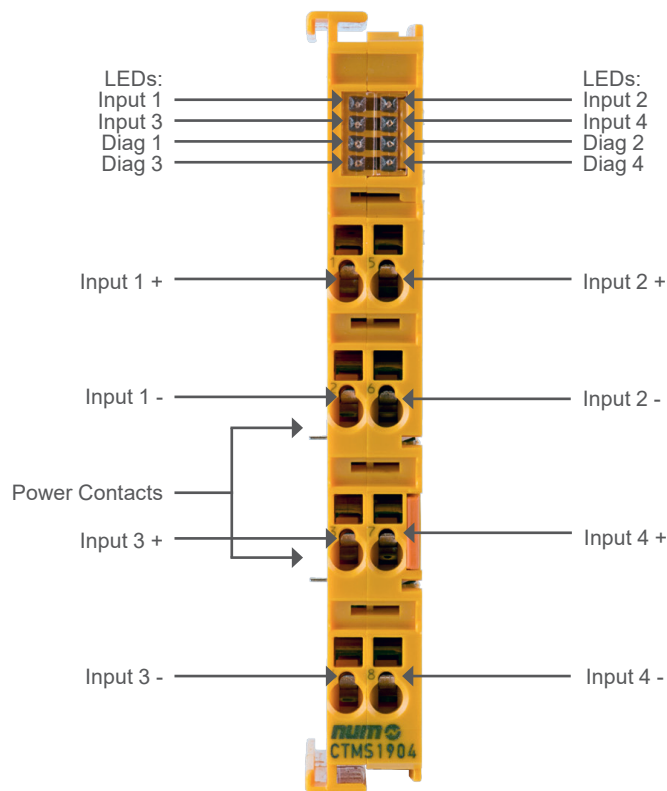



### CTMS1904 - Technical Characteristics

Product Name	CTMS1904
Number of Inputs	4
Number of Outputs	0
Response Time (Read Input / Write to E-Bus)	Typically: 4ms, maximum: see fault response time
Fault Response Time	≤ Watchdog time
Cable Length Between Actuator and Terminal (Un-shielded), (Shielded)	100 m max.(at 0.75 or 1 mm <sup>2</sup> )
Input Process Image	6 bytes
Output Process Image	6 bytes
CTMS1904 Supply Voltage	From NUM EtherCAT Gateway CTMG1100
Current Consumption of the Modular Electronics at 24V (without Current Consumption of Sensors)	4 channels occupied: typically 12mA 0 channels occupied: typically 1.4mA
Current Consumption from the E-Bus	4 channels occupied: approx. 200mA
Power Dissipation of the Terminal	Typically 1 W
Electrical Isolation (Between the Channels)	No
Electrical Isolation (Between the Channels and the E-Bus)	Yes
Insulation Voltage (Between the Channels and the E-Bus, Under Common Operating Conditions)	Insulation tested with 500 VDC
Dimensions (W x H x D)	12 x 100 x 68 mm
Weight	Approx. 50 g
Permissible Ambient Temperature (Operation)	0°C to +55°C
Permissible Ambient Temperature (Transport / Storage)	-25°C to +70°C
Permissible Air Humidity	5% to 95%, non-condensing
Permissible Air Pressure (Operation / Storage / Transport)	750 hPa to 1100 hPa
Climate Class According to EN 60721-3-3	3K3
Permissible Contamination Level	Contamination level 2
Unacceptable Operating Conditions	NUMSafe terminals must not be used under the following operating conditions: <ul style="list-style-type: none"> <li>• under the influence of ionizing radiation</li> <li>• in corrosive environments</li> <li>• in an environment that leads to unacceptable soiling of the EtherCAT Terminal</li> </ul>
Vibration / Shock Resistance	Conforms to EN 60068-2-6 / EN 60068-2-27, EN 60068-2-29
EMC Immunity / Emission	Conforms to EN 61000-6-2 / EN 61000-6-4
Shocks	15 g with pulse duration 11ms in all three axes
Protection Class	IP20
Permitted Operating Environment	Control cabinet or terminal box with minimum protection class IP54 according to IEC 60529
Permissible Installation Position	Please refer to M00032 manual
Approvals	CE, cULus, ATEX

# NUMSafe PLC and Safe I/Os

CTMS1904 - NUMSafe Digital Inputs Terminal  
Outlines and Ordering Code



## CTMS1904 - Outlines

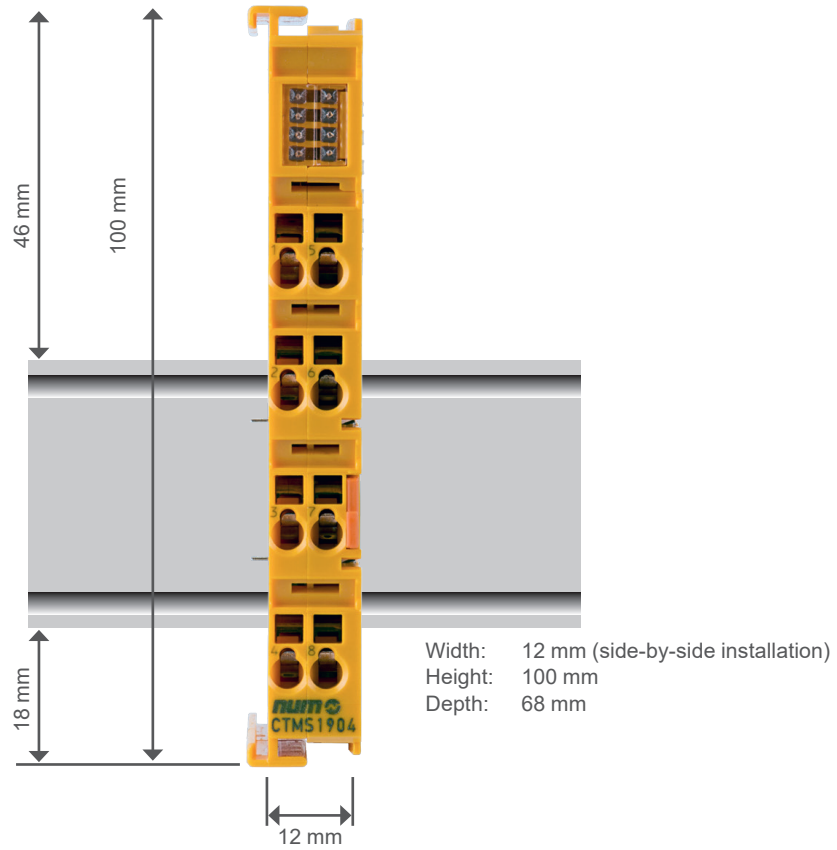

5

## CTMS1904 - Ordering Code

Product	Ordering Codes
4 channels NUMSafe Digital Inputs Terminal	CTMS1904



### CTMS2904 - NUMSafe Digital Outputs Terminal

The CTMS2904 is a safe output terminal with digital outputs for connecting actuators (contactors, relays, etc.) with a maximum current 0.5A (24 VDC).

The EtherCAT terminal has 4 fail-safe outputs.

The CTMS2904 meets the requirements of IEC 61508 SIL 3, EN 954 Cat 4, DIN EN ISO 13849-1:2006 (Cat 4, PL e), NRTL, UL508, UL1998 and UL991.

The NUMSafe Digital Outputs Terminal has the typical design of an EtherCAT terminal.

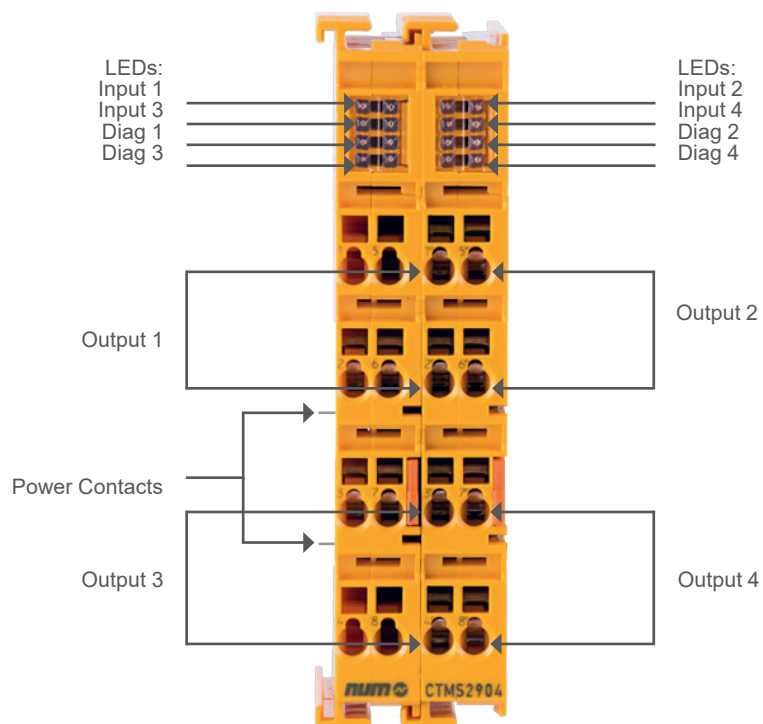



### CTMS2904 - Technical Characteristics

Product Name	CTMS2904
Permissible Contamination Level	0
Number of Outputs	4
Status Display	4 (one green LED per output)
Fault Response Time	≤ Watchdog times
Output Current per Channel	Max. 500mA, min. 20mA with current measurement active
Actuators	When selecting actuators please ensure that the CTMS2904 test pulses do not lead to actuator switching
Cable Length Between Actuator and Terminal (Unshielded), (Shielded)	Max. 100 m
Wire Cross Section	Min. 0.75 mm <sup>2</sup>
Input Process Image	6 bytes
Output Process Image	6 bytes
CTMS2904 Supply Voltage	From NUM EtherCAT Gateway CTMG1100
Current Consumption from the E-Bus	Approx. 221mA
Power Dissipation of the Terminal	Typically 2 W
Electrical Isolation (Between the Channels)	No
Electrical Isolation (Between the Channels and the E-Bus)	Yes
Insulation Voltage (Between the Channels and the E-Bus, Under Common Operating Conditions)	Insulation tested with 500 VDC
Dimensions (W x H x D)	24 x 100 x 68 mm
Weight	Approx. 100 g
Permissible Ambient Temperature (Operation)	0°C to +55°C
Permissible Ambient Temperature (Transport / Storage)	-25°C to +70°C
Permissible Air Humidity	5% to 95%, non-condensing
Permissible Air Pressure (Operation / Storage / Transport)	750 hPa to 1100 hPa
Climate Class According to EN 60721-3-3	3K3
Permissible Contamination Level	Contamination level 2
Unacceptable Operating Conditions	NUMSafe terminals must not be used under the following operating conditions: <ul style="list-style-type: none"> <li>• under the influence of ionizing radiation</li> <li>• in corrosive environments</li> <li>• in an environment that leads to unacceptable soiling of the EtherCAT terminal</li> </ul>
Vibration / Shock Resistance	Conforms to EN 60068-2-6 / EN 60068-2-27, EN 60068-2-29
EMC Immunity / Emission	Conforms to EN 61000-6-2 / EN 61000-6-4
Shocks	15 g with pulse duration 11ms in all three axes
Protection Class	IP20
Permitted Operating Environment	Control cabinet or terminal box with minimum protection class IP54 according to IEC 60529
Permissible Installation Position	Please refer to M00032 manual
Approvals	CE, cULus, ATEX

# NUMSafe PLC and Safe I/Os

## CTMS2904 - NUMSafe Digital Outputs Terminal Outlines and Ordering Code



### CTMS2904 - Outlines

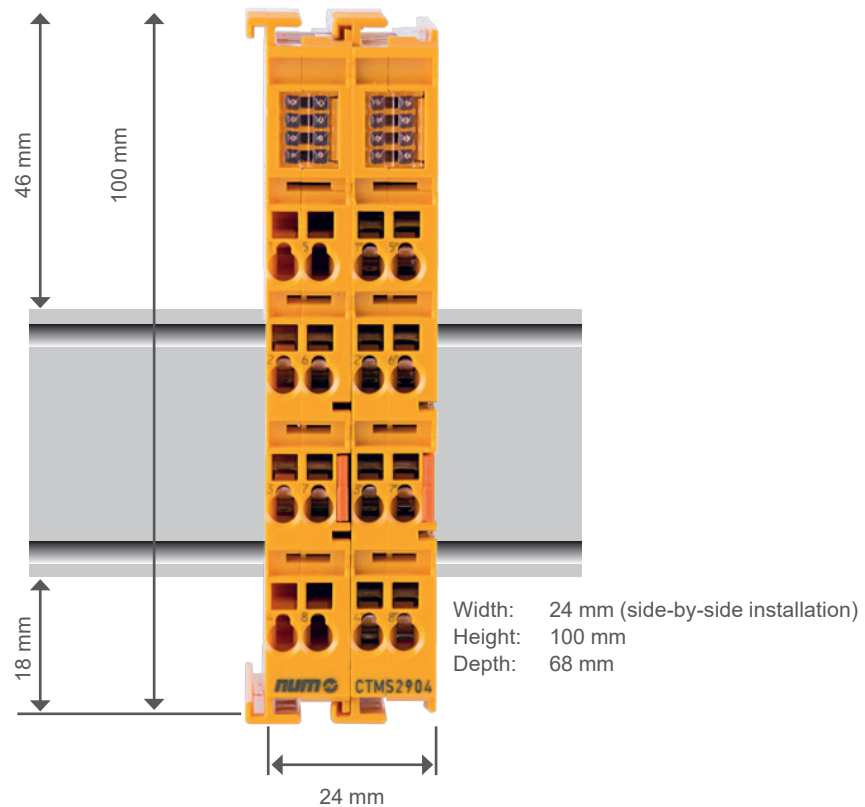

### CTMS2904 - Ordering Code

Product	Ordering Codes
4 channels NUMSafe Digital Outputs Terminal	CTMS2904



### CTMS2912 - NUMSafe Digital Outputs Terminal

The CTMS2912 is a safe output terminal with digital outputs for connecting actuators (contactors, relays, etc.) with a maximum current 2A (24 VDC).

The EtherCAT terminal has 2 fail-safe outputs.

The CTMS2912 meets the requirements of IEC 61508 SIL 3, EN 954 Cat 4, DIN EN ISO 13849-1:2006 (Cat 4, PL e).

The NUMSafe Digital Outputs Terminal has the typical design of an EtherCAT terminal.

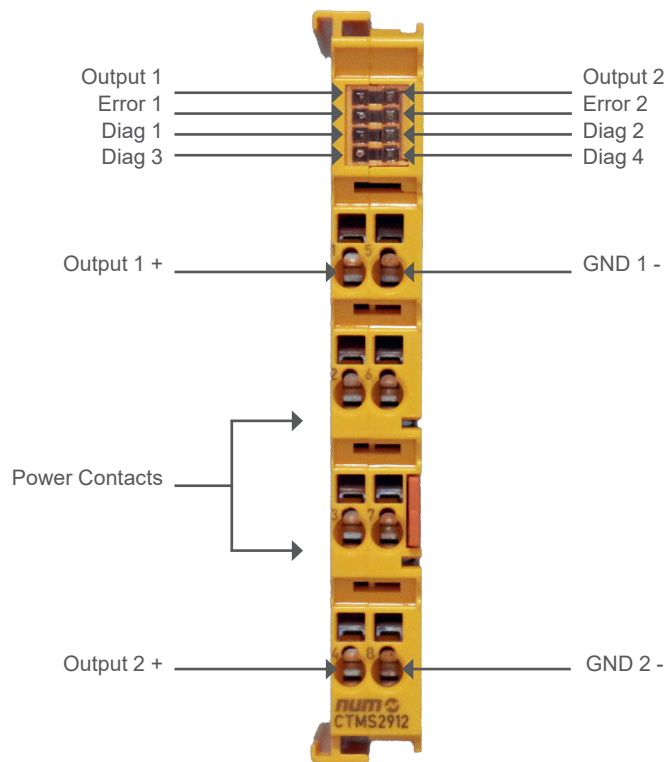





### CTMS2912 - Technical Characteristics

Product Name	CTMS2912
Number of outputs	2
Status display	4 (one green and one red LED for each output)
Fault response time	≤ watchdog times
Output current per channel	max. 2 A (at 24 VDC)
Actuators.	When selecting actuators please ensure that the CTMS2912 test pulses do not lead to actuator switching
Cable length between actuator and terminal	Unshielded max. 100 m Shielded max. 100 m
Wire cross section	min. 0.75 mm <sup>2</sup>
Input process image	6 bytes
Output process image	6 bytes
CTMS2912 supply voltage (SELV/PELV)	24 VDC (-15% / +20%) (A 10 A fuse should be provided for the potential group)
Current consumption from the E-bus	Approx. 200 mA
Power dissipation of the terminal	Typically 1.7 W
Electrical isolation (between the channels)	No
Electrical isolation (between the channels and the E-bus)	Yes
Insulation voltage (between the channels and the E-bus, under common operating conditions)	Insulation tested with 500 VDC
Dimensions (W x H x D)	12 mm x 100 mm x 68 mm
Weight	Approx. 55 g
Permissible ambient temperature (operation)	-25 °C to +55 °C (note chapter Temperature measurement)
Permissible ambient temperature (transport/storage)	-40 °C to +85 °C
Permissible air humidity	5% to 95%, non-condensing
Permissible air pressure (operation/storage/transport)	750 hPa to 1100 hPa (this corresponds to an altitude of approx. -690 m to 2450 m above sea level, assuming an international standard atmosphere)
Climate category according to EN 60721-3-3	3K3 (the deviation from 3K3 is possible only with optimal environmental conditions and also applies only to the technical data which are specified differently in this documentation)
Permissible level of contamination according to EN 60664-1	level of contamination 2 (note chapter Maintenance)
Unacceptable operating conditions	NUMSafe Terminals must not be used under the following operating conditions: <ul style="list-style-type: none"> <li>• under the influence of ionizing radiation (exceeding the natural background radiation)</li> <li>• in corrosive environments</li> <li>• in an environment that leads to unacceptable soiling of the Bus Terminal</li> </ul>
EMC immunity/emission	Conforms to EN 61000-6-2 / EN 61000-6-4 (EMC Zone B)
Vibration resistance	Conforms to EN 60068-2-6 5 Hz ≤ f < 8.4 Hz (3.5 mm peak) 8.4 Hz ≤ f < 150 Hz (10 m/s <sup>2</sup> peak)
Shock resistance	conforms to EN 60068-2-27 15 g with pulse duration 11 ms in all three axes
Protection class	IP20
Permitted operating environment	In the control cabinet or terminal box, with minimum protection class IP54 according to IEC 60529
Permissible installation position	See chapter Installation position and minimum distances
Approvals	CE, TÜV SÜD



# NUMSafe PLC and Safe I/Os

CTMS2912 - NUMSafe Digital Outputs Terminal  
Outlines and Ordering Code



## CTMS2912 - Outlines

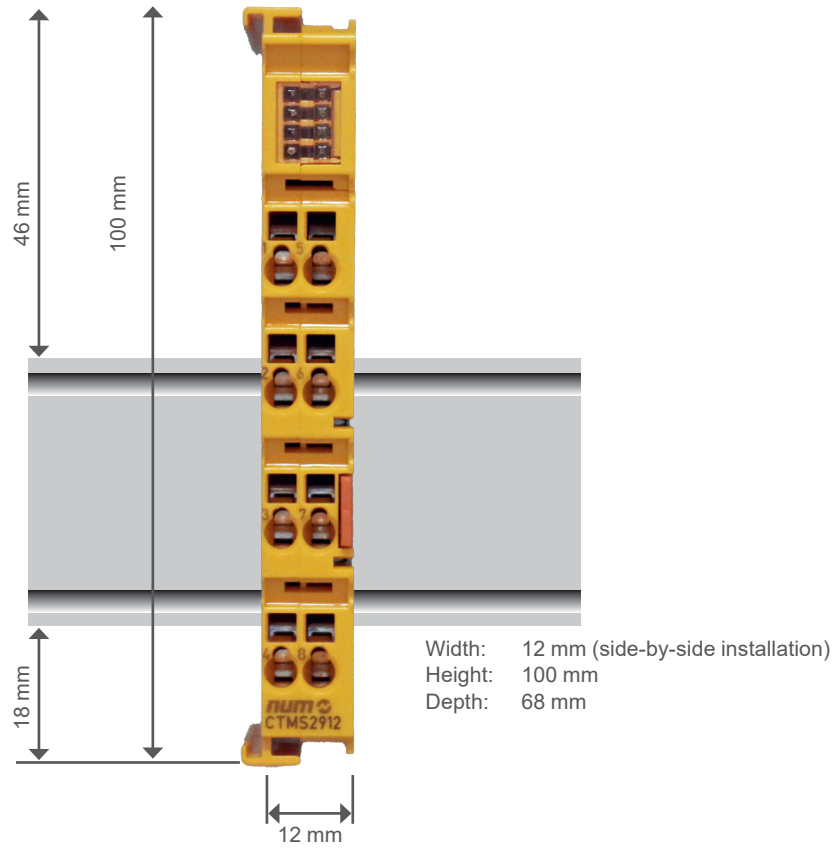

5

## CTMS2912 - Ordering Code

Product	Ordering Codes
2 channels NUMSafe Digital Outputs Terminal, 24V DC 2A	CTMS2912

# NUMSafe PLC and Safe I/Os

## CTMP1960-2600 - NUMSafe Compact Controller



### CTMP1960-2600 - NUMSafe Compact Controller

NUMSafe Compact Controller CTMP1960-2600, the all-in-one solution for safety applications. It integrates an EtherCAT gateway, a complete safety controller including I/O with 20 safe digital inputs, 24 safe digital outputs and 4 potential-free contacts (NO).

Thanks to its design, with 20 safe digital inputs and 24 safe digital outputs, it covers the complete safety requirements for compact machines. Like every EtherCAT gateway, the CTMP1960-2600 can be extended with all CTMT/CTMS terminals by means of a CTMT9100, at least.

The NUMSafe Compact Controller is programmed via FlexiumPro Tools (Safety Editor) in the same way as other NUMSafe components.

The device is TÜV Süd certified; it's suitable for applications up to SIL 3 according to EN 61508:2010 and Cat 4, PL e according to EN ISO 13849-1:2015.

For NUMSafe Compact controller the EtherCAT Safe PLC Option FPSW282305 is required.

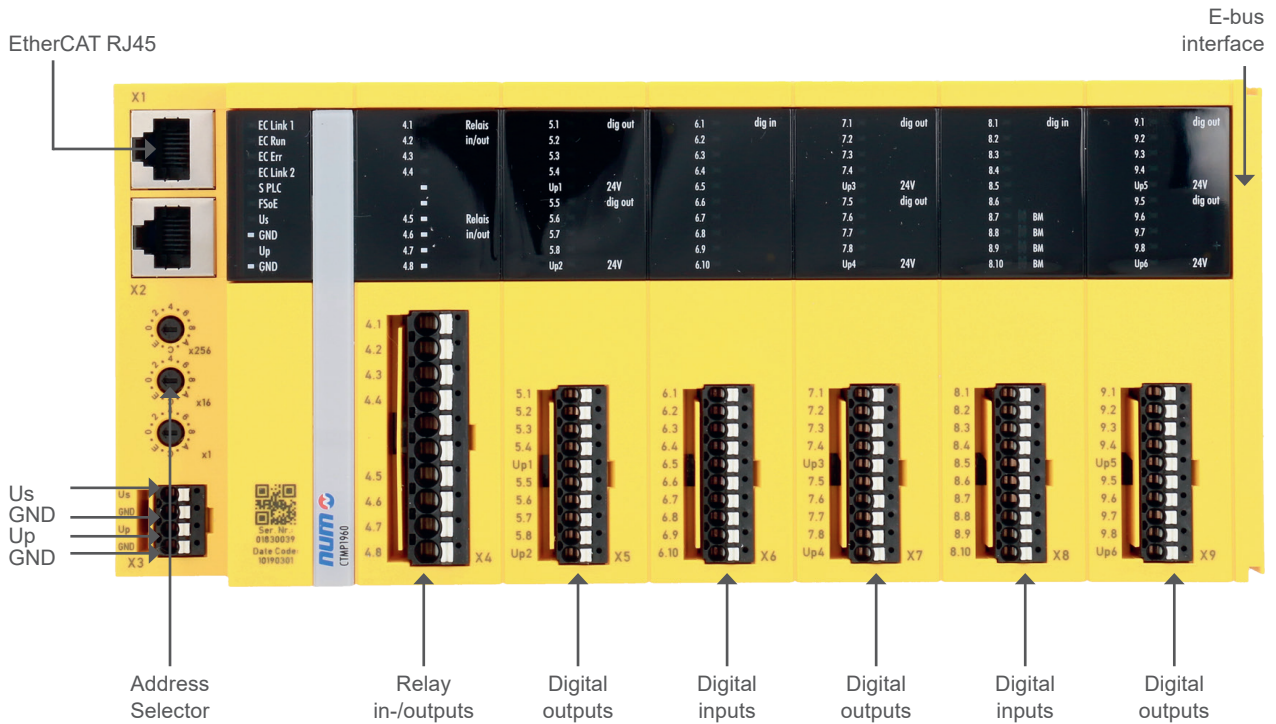



### CTMP1960-2600 - Technical Characteristics

Product Name	CTMP1960-2600
Technology	NUMSafe Compact Controller
Distance between stations	100 m (100BASE-TX)
Number of EtherCAT Terminals	up to 65,534
Bus interface	2 x RJ45
Safety standard	EN ISO 13849-1:2015 (Cat 4, PL e) and EN 61508:2010 (SIL 3)
Number of communication partners	max. 128
Protocol	EtherCAT
Safety protocol	Safety over EtherCAT
Function blocks	Max. 512 (ESTOP with complete input and output mapping)
Nominal voltage	24 VDC (-15 %/+20 %)
E-bus power supply (5 V)	max. 500 mA (In the case of higher current consumption, please use the CTMT9410 power feed terminals in addition!)
Cycle time	< 10 ms
Response time	dependent on application (< 15 ms)
Fault response time	≤ watchdog time (parameterizable)
Connection method	1-wire
Number of inputs	20
Number of outputs	24 (6 module with 4 outputs each)
Number of potential free (NO) outputs	4
Max. output current	2 A (simultaneity factor 50 % at 2 A) for each module
Dimensions (W x H x D)	230.5 mm x 100 mm x 58.6 mm
Permitted degree of contamination	2
Climate class EN 60721-3-3	3K3
Operating/storage temperature	-25...+55 °C/-40...+70 °C
EMC immunity/emission	conforms to EN 61000-6-2/EN 61000-6-4
Vibration/shock resistance	conforms to EN 60068-2-6/EN 60068-2-27
Protect. class/installation pos.	IP 20/horizontal
Approvals	CE, TÜV SÜD

# NUMSafe PLC and Safe I/Os

CTMP1960-2600 - NUMSafe Compact Controller  
 Outlines and Ordering Code



## CTMP1960-2600 - Outlines

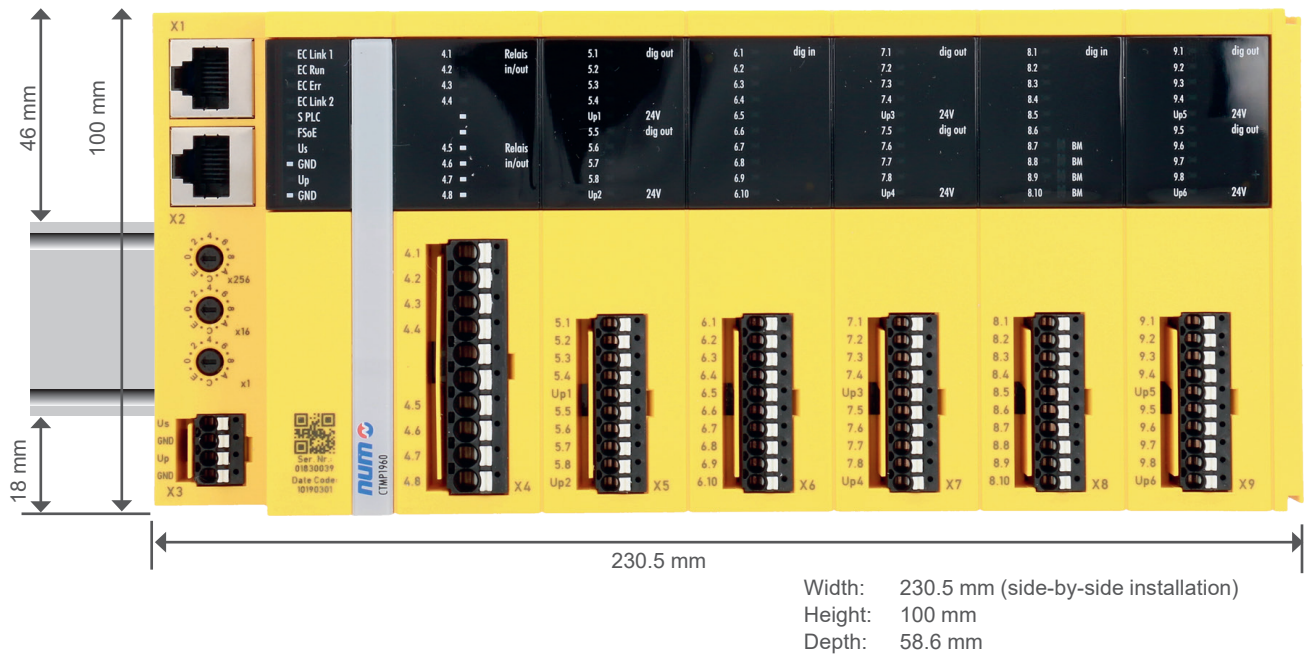

## CTMP1960-2600 - Ordering Code

Product	Ordering Codes
NUMSafe Compact Controller	CTMP1960-2600





## Overview and Product Positioning

---

NUM manufactures a comprehensive range of motors, all featuring high power-to-weight ratios and excellent dynamic range. Availability of a vast variety of motors enables NUM to provide solutions that are perfectly tailored to each application.

In conjunction with NUMDrive servo drives these motors offer excellent stability even at very low rotational speeds.

NUM motors are equipped with robust optical encoders of different resolution/accuracy levels to fit the requirements of the machine and the application.

Developed for use with NUM's latest-generation NUM DrivePro digital servo drives and FlexiumPro CNC platform, our innovative SHX and SPX brushless servomotors only require a single cable connection, providing major savings by eliminating the need for a separate encoder cable. Machine builders can now use a single drive-to-motor cable for each motion axis, thereby reducing cabling, speeding installation/commissioning, and improving system performance.

An innovative embedded digital interface scheme allows the encoder power and position feedback data – together with diagnostic information and thermal data from the motor's temperature sensor – to be carried on just two shielded wires contained within the motor's power cable. This approach has significant advantages for machine builders. In addition to lower cabling costs, cable chains are smaller and lighter, the onerous task of installing and debugging cable runs is much less time consuming, and the reduced number of interconnections improves reliability and immunity to electromagnetic interference.

NUM also offers a wide choice of built-in and liquid-cooled motors, including custom designed models. For details about any of these types of motors, please contact your local NUM sales office.





### Product Positioning

The different motor ranges are positioned as shown in the table below:

Motor Range	Main Characteristics	Typical Applications	Cont. Torque / Power Range	Available Sizes	Available Options
<b>SHX</b>	Single cable servomotor with very compact design, medium inertia, IP64	Designed for feeding axes of cost sensitive machine tools	From 1.2 Nm up to 20 Nm	Frame sizes 75 mm 95 mm 126 mm 155 mm	Holding brake Keyed shaft Medium and high resolution single/multi turn encoder High inertia version
<b>SPX</b>	Single cable servomotor with extremely compact design, high peak torques, smooth operation, medium inertia, IP67	Designed for feeding axes of high-end machine tools, grinding machines, robotics and special machines	From 0.5 Nm up to 23 Nm	Frame sizes 75 mm 95 mm 126 mm 155 mm	Holding brake Keyed shaft Medium and high resolution single/multi turn encoder High inertia version
<b>BHX</b>	Very compact design, medium inertia, IP64 servomotor	Designed for feeding axes of cost sensitive machine tools	From 1.2 Nm up to 20 Nm	Frame sizes 75 mm 95 mm 126 mm 155 mm	Holding brake Keyed shaft Medium and high resolution single/multi turn encoder High inertia version
<b>BPX</b>	Extremely compact design, high peak torques, smooth operation, medium inertia, IP67 servomotor	Designed for feeding axes of high-end machine tools, grinding machines, robotics and special machines	From 0.5 Nm up to 23 Nm	Frame sizes 55 mm 75 mm 95 mm 126 mm 155 mm	Holding brake Keyed shaft Medium and high resolution single/multi turn encoder High inertia version
<b>BPH</b>	Compact design, smooth operations, medium inertia, up to IP67 servomotor	Designed for feeding axes of high-end machine tools, grinding machines, robotics and special machines	From 1.3 Nm up to 100 Nm	Frame sizes 75 mm 95 mm 115 mm 142 mm 190 mm	Holding brake Keyed shaft Medium and high resolution single/multi turn encoder IP67 degree of protection
<b>BPG</b>	Compact design, smooth operation, very high inertia, up to IP67 servomotor	Designed for feeding axes of high end machine tools, grinding machines, robotics and special machines	From 1.3 Nm up to 56 Nm	Frame sizes 75 mm 95 mm 115 mm 142 mm 190 mm	Keyed shaft Medium and high resolution single/multi turn encoder IP67 degree of protection
<b>BHL</b>	Very compact design, high inertia, IP64 servomotor	Designed for feeding axes of large machine tools	From 85 Nm up to 160 Nm	Frame sizes 260 mm	Holding brake Keyed shaft Medium and high resolution single/multi turn encoder
<b>TMX</b>	Torque motor	Designed for direct drives	From 33 Nm up to 325 Nm	Stator diameter 140 mm 210 mm 291 mm	None
<b>AMS/IM</b>	Compact fan cooled spindle motor	Designed for main spindles	From 2.2 kW up to 55 kW	Shaft height 100 mm 132 mm 160 mm 180 mm	Keyed shaft High resolution single/multi turn encoder Low vibration level High radial loads

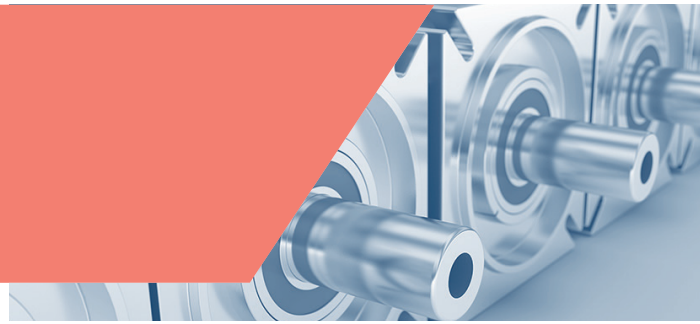

### Product Positioning

Motor Range	Front	Profile	Lateral
SHX			
SPX			
BHX			
BPX			
BPH			
TMX			
AMS			





### General Characteristics

BHX and SHX servomotors are very compact medium inertia units, designed for the feeding axes of cost sensitive machine tools. They are available in 75 mm, 95 mm, 126 mm and 155 mm frame sizes, with a variety of options.

SHX servomotors are mechanically identical to BHX servomotors and have the same basic characteristics. However, thanks to an innovative encoder protocol, SHX servomotors only require a single cable to connect with NUM DrivePro drives.

General Motor Features	As per EN60034-1
Environment Storage Conditions • Temperature Range • Relative Humidity	-20 to +80 °C max. 80% without condensation
Environment Working Conditions • Temperature Range • Altitude	0 to 40 °C without derating, max. 55 °C with derating 0 to 1000 m without derating, max. 3000 m with derating
Continuous Stall Torque Range	From 1.2 to 20 Nm
Degree of protection as per EN60529	Housing IP64, shaft IP54
Connection	By rotary connector
Permanent Magnet Holding Brake	24 VDC available as option (excluding for high inertia version)
Motor Transducer	High resolution single turn and multi turn optical encoder Medium resolution single turn and multi turn optical encoder High resolution single turn and multi turn optical encoder 2 wires (for SHX only) Medium resolution single turn and multi turn optical encoder 2 wires (for SHX only)
Mounting Restriction	No mounting restrictions, IMB5 - IMV1 - IMV3 as per EN60034-7
Finishing	Not painted, dielectric varnish only

### Technical Characteristics

For peak torque figures please refer to chapter 7 where the drive-motor associations are described.

BHX SHX	Low speed continuous torque	Rated speed	Rotor Inertia			Motor weight			Brake		Low speed continuous current	Dimensioning Power
			without brake	with brake	high inertia version	without brake	with brake	high inertia version	Torque	Current		
			[g.m <sup>2</sup> ]	[g.m <sup>2</sup> ]	[g.m <sup>2</sup> ]	[kg]	[kg]	[kg]	[Nm]	[A]		
0751V5...	1.2	6 000	0.07	0.08	0.12	2.1	2.3	2.4	2.2	0.4	1.7	0.75
0752V5...	2.1	6 000	0.13	0.14	0.18	3.1	3.3	3.4			3.1	1.32
0951V5...	2.4	6 000	0.20	0.26	0.54	3.4	4.1	4.3	6.0	0.7	3.0	1.51
0952N5...	4.3	3 000	0.37	0.43	0.71	4.8	5.5	5.7			2.8	1.35
0952V5...		6 000							5.6	2.70		
1261N5...	4.5	3 000	0.55	0.69	1.49	5.5	7.0	7.2	13.0	0.8	3.2	1.41
1261V5...		6 000									6.4	2.83
1262N5...	8.4	3 000	1.07	1.21	2.01	8.0	9.5	9.7	13.0	0.8	6.0	2.64
1262V5...		6 000									12.0	5.28
1263R5...	11.0	4 500	1.58	1.72	2.52	10.6	12.1	12.3	29.0	0.9	10.0	5.18
1552N5...	12.0	3 000	2.45	2.86	5.25	11.6	13.8	14.3			7.5	3.80
1552R5...		4 500							10.2	5.70		
1554N5...	20.0	3 000	4.76	5.17	7.56	18.2	20.4	20.9	29.0	0.9	12.4	6.30



### BHX Servomotor Ordering Codes

	BHX	075	1	V	5	Q	A	2	L	0	0
<b>Series</b>											
<b>Size</b> (075, 095, 126, 155)											
<b>Length</b>											
<b>Winding type</b>											
<b>Connection type</b>											
• Standard right-angled M23 rotatable connectors					5						
<b>Sensor type</b>											
• High resolution multi-turn encoder						P					
• High resolution single-turn encoder						Q					
• Medium resolution multi-turn encoder						J					
• Medium resolution single-turn encoder						K					
<b>Brake</b>											
• Without brake							A				
• With brake							F				
• High inertia version <sup>1</sup>							G				
<b>Version</b>											
• Standard								2			
<b>Shaft extension</b>											
• Smooth									L		
• Keyed									C		
<b>Type of customization</b>											
• Standard										0	
<b>Degree of protection (shaft extension/frame)</b>											
• IP 54/64											0

<sup>1</sup> Brake option not available



### SHX Servomotor Ordering Codes

	SHX	075	1	V	5	Y	A	2	L	0	0
<b>Series</b>											
<b>Size</b> (075, 095, 126, 155)											
<b>Length</b>											
<b>Winding type</b>											
<b>Connection type</b>											
• Standard right-angled M23 rotatable connectors					5						
<b>Sensor type</b>											
• High resolution multi-turn encoder 2-wires						Y					
• High resolution single-turn encoder 2-wires						Z					
• Medium resolution multi-turn encoder 2-wires						I					
• Medium resolution single-turn encoder 2-wire						L					
<b>Brake</b>											
• Without brake							A				
• With brake							F				
• High inertia version <sup>1</sup>							G				
<b>Version</b>											
• Standard								2			
<b>Shaft extension</b>											
• Smooth									L		
• Keyed									C		
<b>Type of customization</b>											
• Standard										0	
<b>Degree of protection (shaft extension/frame)</b>											
• IP54/64											0

<sup>1</sup> Brake option not available

### BHX & SHX Servomotor Outlines

See pages 169-171 for BHX, SHX, BPX & SPX servomotor outlines.

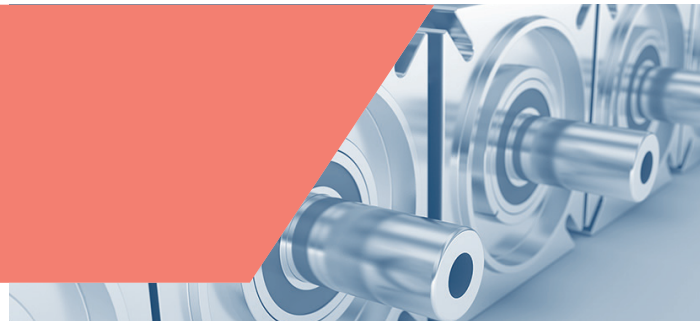

### General Characteristics

BPX and SPX servomotors are extremely compact medium inertia units with a high peak torque capability, designed for the feeding axes of high-end machine tools, grinding machines, robotics and special machines. They are available in 55 mm, 75 mm, 95 mm, 126 mm and 155 mm frame sizes, with a variety of options. SPX servomotors are mechanically identical to BPX servomotors and have the same basic characteristics. However, thanks to an innovative encoder protocol, SPX servomotors only require a single cable to connect with NUM DrivePro drives.

General Motor Features	As per EN60034-1
Environment Storage Conditions • Temperature Range • Relative Humidity	-20 to +80 °C max. 80% without condensation
Environment Working Conditions • Temperature Range • Altitude	0 to 40 °C without derating, max. 55 °C with derating 0 to 1000 m without derating, max. 3000 m with derating
Continuous Stall Torque Range	From 0.5 to 23 Nm
Degree of protection as per EN60529	IP67 (Excluding BPX055)
Connection	By rotary connector
Permanent Magnet Holding Brake	24 VDC available as option (excluding the high inertia version)
Motor Transducer	High resolution single turn and multi turn optical encoder Medium resolution single turn and multi turn optical encoder High resolution single turn and multi turn optical encoder 2 wires (for SPX only) Medium resolution single turn and multi turn optical encoder 2 wires (for SPX only)
Mounting Restriction	No mounting restrictions, IMB5 - IMV1 - IMV3 as per EN60034-7
Finishing	Black glossy polyurethane varnish

### Technical Characteristics

For peak torque figures please refer to chapter 7 where the drive-motor associations are described.

BPX SPX	Low speed continuous torque	Rated speed	Rotor Inertia			Motor weight			Brake		Low speed continuous current	Dimens. Power
			without brake	with brake	high inertia version	without brake	with brake	high inertia version	Torque	Current		
	[Nm]	[rpm]	[g.m <sup>2</sup> ]	[g.m <sup>2</sup> ]	[g.m <sup>2</sup> ]	[kg]	[kg]	[kg]	[Nm]	[A]	[Arms]	[kW]
0551V5... <sup>1</sup>	0.5	6 000	0.006	0.008	-	1.2	1.4	-	0.8	0.4	0.7	0.31
0751V5...	1.4	6 000	0.07	0.08	0.12	2.2	2.4	2.5	2.2	0.4	2.0	0.88
0752V5...	2.3	6 000	0.13	0.14	0.18	3.2	3.4	3.5			3.4	1.45
0951V5...	2.7	6 000	0.20	0.26	0.54	3.6	4.3	4.5	6.0	0.7	3.4	1.70
0952N5...	5.0	3 000	0.37	0.43	0.71	5.2	5.9	6.1			3.3	1.57
0952V5...		6 000									6.6	3.14
1261N5...	5.2	3 000	0.55	0.69	1.49	6.0	7.5	7.7	13.0	0.8	3.7	1.63
1261V5...		6 000									7.4	3.27
1262N5...	9.8	3 000	1.07	1.21	2.01	8.5	10.0	10.2			7.0	3.08
1262V5...		6 000									14.0	6.16
1263R5...	12.6	4 500	1.58	1.72	2.52	11.2	12.7	12.9	11.5	5.94		
1552N5...	13.8	3 000	2.45	2.86	5.25	12.5	14.7	15.2	29.0	0.9	8.7	4.34
1552R5...		4 500									11.7	6.50
1554N5...		3 000									4.76	5.17

<sup>1</sup> SPX version not available



### BPX Servomotor Ordering Codes

	BPX	075	1	V	5	Q	A	2	L	0	2
<b>Series</b>											
<b>Size</b> (055, 075, 095, 126, 155)											
<b>Length</b>											
<b>Winding type</b>											
<b>Connection type</b>											
• Standard right-angled M23 rotatable connectors					5						
<b>Sensor type</b>											
• High resolution multi-turn encoder <sup>3</sup>						P					
• High resolution single-turn encoder <sup>3</sup>						Q					
• Medium resolution multi-turn encoder						J					
• Medium resolution single-turn encoder <sup>3</sup>						K					
<b>Brake</b>											
• Without brake							A				
• With brake							F				
• High inertia version <sup>1,4</sup>							G				
<b>Version</b>											
• Standard								2			
<b>Shaft extension</b>											
• Smooth									L		
• Keyed									C		
<b>Type of customization</b>											
• Standard										0	
<b>Degree of protection (shaft extension/frame)</b>											
• IP 65/65 <sup>2</sup>											1
• IP 67/67											2

<sup>1</sup> Brake option not available  
<sup>2</sup> Mandatory choice for BPX055, not available for other sizes  
<sup>3</sup> Sensor type not available for BPX055  
<sup>4</sup> Option not available for BPX055



### SPX Servomotor Ordering Codes

	SPX	075	1	V	5	Y	A	2	L	0	2
<b>Series</b>											
<b>Size</b> (075, 095, 126, 155)											
<b>Length</b>											
<b>Winding type</b>											
<b>Connection type</b>											
• Standard right-angled M23 rotatable connectors					5						
<b>Sensor type</b>											
• High resolution multi-turn encoder 2-wires						Y					
• High resolution single-turn encoder 2-wires						Z					
• Medium resolution multi-turn encoder 2-wires						I					
• Medium resolution single-turn encoder 2-wires						L					
<b>Brake</b>											
• Without brake							A				
• With brake							F				
• High inertia version <sup>1</sup>							G				
<b>Version</b>											
• Standard								2			
<b>Shaft extension</b>											
• Smooth									L		
• Keyed									C		
<b>Type of customization</b>											
• Standard										0	
<b>Degree of protection (shaft extension/frame)</b>											
• IP 67/67											2

<sup>1</sup> Brake option not available



### Servomotor Outlines

**bhx**  
**bpX**

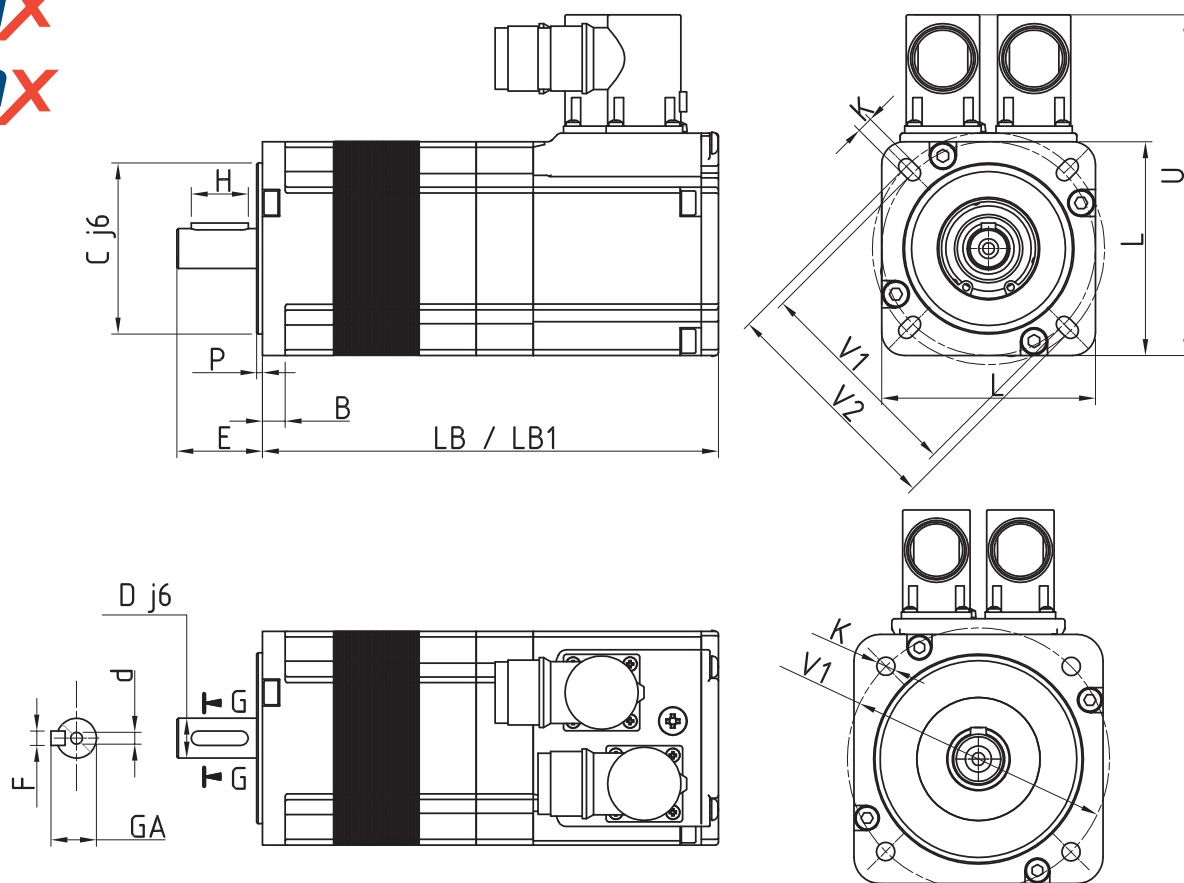

6

BHX BPX	L	LB <sup>1</sup>	LB1 <sup>1</sup>	C	P	B	V1	V2	K	U	D	E	H	F	GA	d
	[mm]	[mm]	[mm]	[mm]	[mm]	[mm]	[mm]	[mm]	[mm]	[mm]	[mm]	[mm]	[mm]	[mm]	[mm]	[mm]
0751...	75	140	160	60	2.5	8	75	81.5	5.5	119.5	14	30	20	5	16.0	M5x10
0752...		170	190													
0951...	95	153	183	80	3.0	10	100	-	7.0	140.5	19	40	30	6	21.5	M6x16
0952...		183	213													
1261...	126	149	194	110	3.5	11	130	-	9.0	175.0	24	50	40	8	27.0	M8x19
1262...		179	224													
1263...		209	254													
1552...	155	192	235	130	3.5	13	165	-	11.0	200.0	32	58	45	10	35.0	M12x28
1554...		242	285													

<sup>1</sup> LB without brake, LB1 with brake or high inertia version



#### BPX 055 Servomotor Outlines

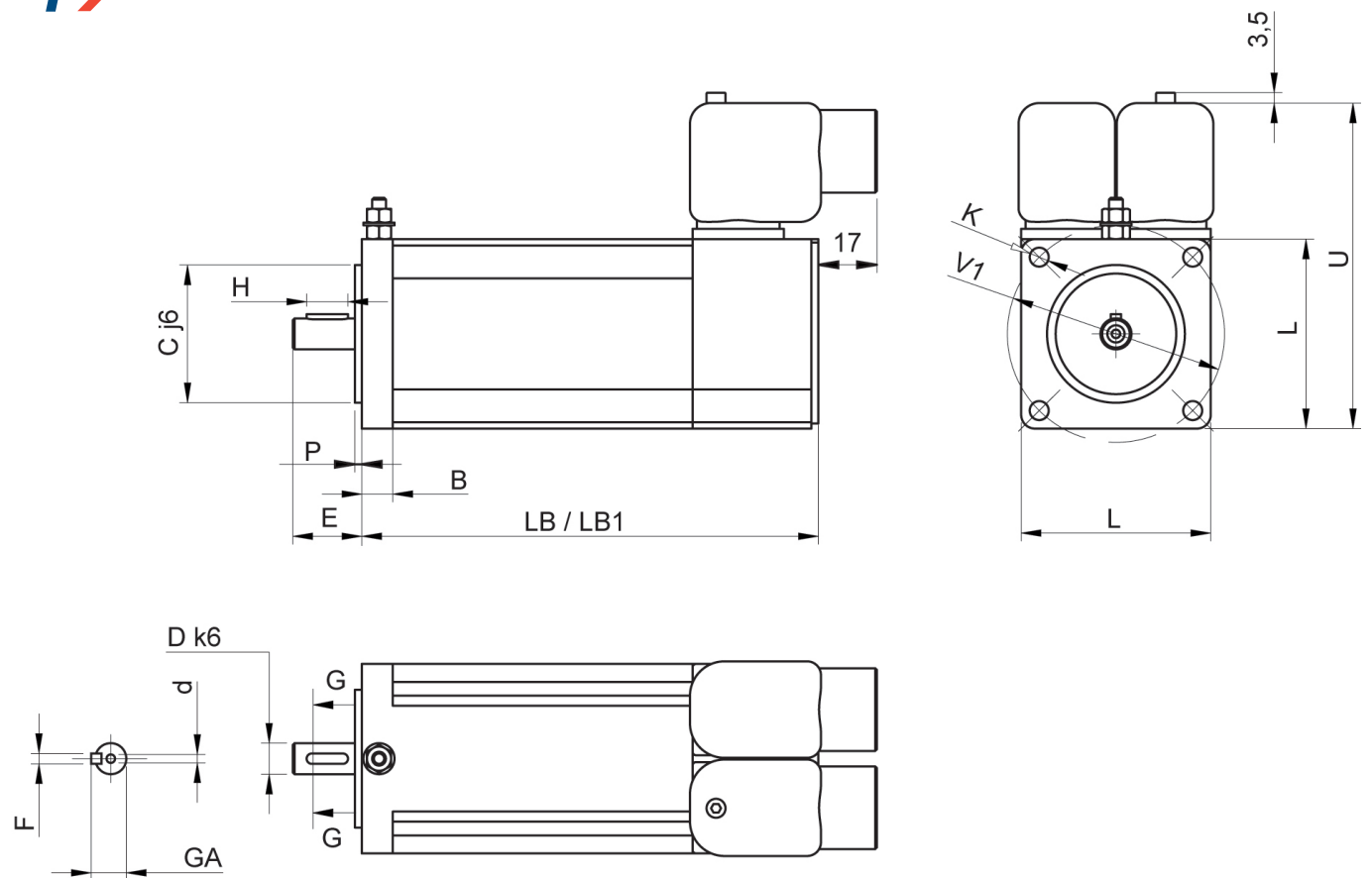

BPX	L	LB	LB1 <sup>1</sup>	C	P	B	V1	K	U	D	E	H	F	GA	d
	[mm]	[mm]	[mm]	[mm]	[mm]	[mm]	[mm]	[mm]	[mm]	[mm]	[mm]	[mm]	[mm]	[mm]	[mm]
0551	55	133	159	40	2	9	63	5.5	94.5	9	20	12	3	10.2	M3x9





#### Servomotor Outlines

**shx**  
**spx**

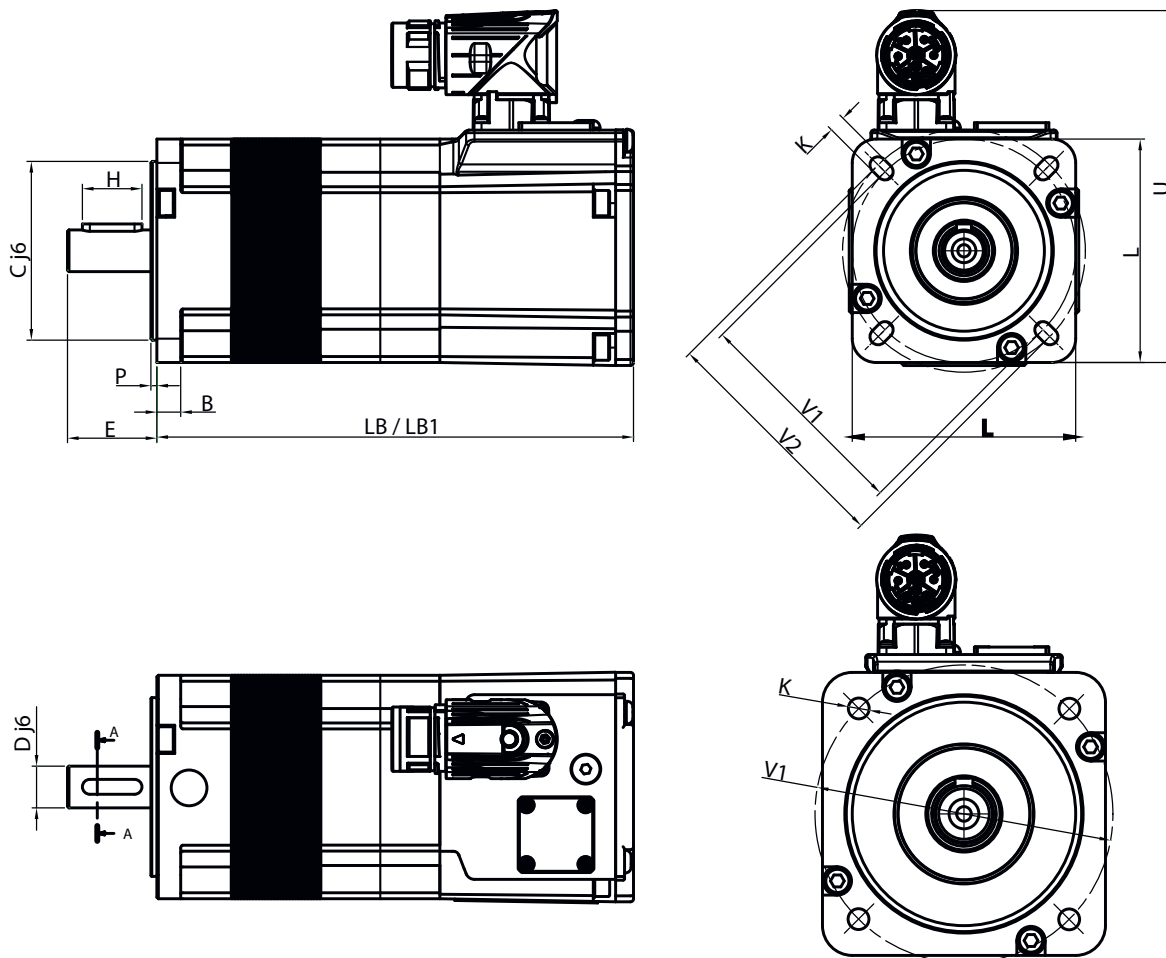

6

SHX SPX	L	LB <sup>1</sup>	LB1 <sup>1</sup>	C	P	B	V1	V2	K	U	D	E	H	F	GA	d
	[mm]	[mm]	[mm]	[mm]	[mm]	[mm]	[mm]	[mm]	[mm]	[mm]	[mm]	[mm]	[mm]	[mm]	[mm]	[mm]
0751...	75	140	160	60	2.5	8	75	81.5	5.5	119.5	14	30	20	5	16.0	M5x10
0752...		170	190													
0951...	95	153	183	80	3.0	10	100	-	7.0	140.5	19	40	30	6	21.5	M6x16
0952...		183	213													
1261...	126	149	194	110	3.5	11	130	-	9.0	175.0	24	50	40	8	27.0	M8x19
1262...		179	224													
1263...		209	254													
1552...	155	192	235	130	3.5	13	165	-	11.0	200.0	32	58	45	10	35.0	M12x28
1554...		242	285													

<sup>1</sup> LB without brake, LB1 with brake or high inertia version



### BPH Servomotor General Characteristics

BPH servomotors are compact medium inertia units, designed for the feeding axes of high-end machine tools, grinding machines, robotics and special machines. They are available in 75 mm, 95 mm, 115 mm, 142 mm and 190 mm frame sizes, with a variety of options.

General Motor Features	As per EN60034-1
Environment Storage Conditions <ul style="list-style-type: none"> <li>• Temperature Range</li> <li>• Relative Humidity</li> </ul>	-20 to +80 °C max. 80% without condensation
Environment Working Conditions <ul style="list-style-type: none"> <li>• Temperature Range</li> <li>• Altitude</li> </ul>	0 to 40 °C without derating, max. 55 °C with derating 0 to 1000 m without derating, max. 3000 m with derating
Continuous Stall Torque Range	From 1.3 to 100 Nm
Degree of protection as per EN60529	IP65 IP67 as option
Connection	By 90° connector
Permanent Magnet Holding Brake	24 VDC available as option
Motor Transducer	High resolution single turn and multi turn optical encoder Medium resolution single turn and multi turn optical encoder
Mounting Restriction	No mounting restrictions, IMB5 - IMV1 - IMV3 as per EN60034-7
Finishing	Black



## BPH Servomotor Technical Characteristics

For peak torque figures please refer to chapter 7 where the drive-motor associations are described.

BPH	Low Speed Continuous Torque	Rated Speed	Rotor Inertia		Motor Weight		Brake		Low Speed Continuous Current	Dimensioning Power	
			Without Brake	With Brake	Without Brake	With Brake	Torque	Current			
	[Nm]	[rpm]	[g.m <sup>2</sup> ]	[g.m <sup>2</sup> ]	[kg]	[kg]	[Nm]	[A]	[Arms]	[kW]	
0751N5...	1.3	3 000	0.08	0.12	3.5	3.85	2.5	0.5	2.2	0.41	
0751V5...		6 000							3.0	0.82	
0752N5...	2.3	3 000	0.12	0.16	4.3	4.65			2.7	0.72	
0752V5...		6 000							3.5	1.45	
0754N5...	4.0	3 000	0.21	0.25	6.0	6.35			3.5	1.26	
0952N5...	4.3	3 000	0.30	0.41	6.7	7.50			5.0	0.7	3.5
0952V5...		6 000					5.9	2.70			
0953N5...	6.0	3 000	0.41	0.52	8.0	8.80	5.2	1.88			
0953V5...		6 000					10.3	3.77			
0955N5...	9.2	3 000	0.64	0.75	10.5	11.30	11.0	5.8			2.89
1152N5...	7.4	3 000	0.70	1.07	9.6	10.90	12.0	0.8			5.5
1152V5...		6 000							10.5	4.65	
1153K5...	10.5	2 000	0.97	1.34	11.7	13.00			5.3	2.20	
1153N5...		3 000							9.2	3.30	
1153V5...		6 000							12.6	6.60	
1154K5...	13.3	2 000	1.25	1.62	13.8	15.10			6.2	2.79	
1154N5...		3 000					10.1	4.18			
1154V5...		6 000					17.6	8.36			
1156N5...	18.7	3 000	1.80	2.17	17.9	19.20	22.0	12.0	5.87		
1422K5...	12.0	2 000	1.59	2.54	17.2	19.40	20.0	1.0	6.0	2.51	
1422N5...		3 000							10.4	3.77	
1422R5...		4 250							11.5	5.34	
1423K5...	17.0	2 000	2.19	3.14	20.1	22.30			9.5	3.56	
1423N5...		3 000							11.7	5.34	
1423R5...		4 250							16.9	7.57	
1424K5...	22.0	2 000	2.79	3.74	23.0	25.20	10.4	4.61			
1424N5...		3 000					15.6	6.91			
1424R5...		4 250					20.8	9.79			
1427N5...	35.0	3 000	4.29	5.24	31.7	33.90	40.0	24.2	11.00		
1902K5...	25.0	2 000	5.14	8.25	32.1	36.20	40.0	1.5	16.6	5.24	
1902N5...		3 000							19.9	7.85	
1902R5...		4 250							29.2	11.13	
1903K5...	36.0	2 000	7.10	10.20	37.3	41.40			19.7	7.54	
1903N5...		3 000							27.8	11.31	
1904K5...	46.0	2 000	9.04	12.10	42.4	46.50			20.6	9.63	
1904N5...		3 000					30.3	14.45			
1905H5...	56.0	1 500	11.00	14.10	47.6	51.70	80.0	20.0	8.80		
1905L5...		2 500						31.4	14.66		
1907K5...	75.0	2 000	14.90	18.00	58.0	62.10		27.9	15.71		
1907N5...		3 000						52.3	23.56		
190AK5...	100.0	2 000	20.75	23.80	73.9	78.00		44.0	20.94		



### BPH Servomotor Ordering Codes

	<b>BPH</b>	<b>075</b>	<b>1</b>	<b>N</b>	<b>5</b>	<b>Q</b>	<b>A</b>	<b>2</b>	<b>L</b>	<b>0</b>	<b>1</b>
<b>Series</b>											
<b>Size</b> (075, 095, 115, 142, 190)											
<b>Length</b>											
<b>Winding type</b>											
<b>Fixed value</b>					5						
<b>Sensor type</b>											
<ul style="list-style-type: none"> <li>High resolution multi-turn encoder</li> <li>High resolution single-turn encoder</li> <li>Medium resolution multi-turn encoder</li> <li>Medium resolution single-turn encoder</li> </ul>						P	Q	J	K		
<b>Brake</b>											
<ul style="list-style-type: none"> <li>Without brake</li> <li>With brake</li> </ul>							A	F			
<b>Fixed value</b>								2			
<b>Shaft extension</b>											
<ul style="list-style-type: none"> <li>Smooth</li> <li>Keyed</li> </ul>									L	C	
<b>Fixed value</b>											0
<b>Degree of protection (shaft extension/frame)</b>											
<ul style="list-style-type: none"> <li>IP 65/65</li> <li>IP 67/67 option</li> </ul>											1
											2

### BPH Servomotor Outlines

See page 177 for BPH & BPG servomotor outlines.



### BPG Servomotor General Characteristics

BPG servomotors are compact very high inertia units, designed for the feeding axes of high-end machine tools, grinding machines, robotics and special machines. They are available in 75 mm, 95 mm, 115 mm, 142 mm and 190 mm frame sizes, with a variety of options.

General Motor Features	As per EN60034-1
Environment Storage Conditions • Temperature Range • Relative Humidity	-20 to +80 °C max. 80% without condensation
Environment Working Conditions • Temperature Range • Altitude	0 to 40 °C without derating, max. 55 °C with derating 0 to 1000 m without derating, max. 3000 m with derating
Continuous Stall Torque Range	From 1.3 to 56 Nm
Degree of protection as per EN60529	IP65 IP67 as option
Connection	By 90° connector
Permanent Magnet Holding Brake	Not available
Motor Transducer	High resolution single turn and multi turn optical encoder Medium resolution single turn and multi turn optical encoder
Mounting Restriction	No mounting restrictions, IMB5 - IMV1 - IMV3 as per EN60034-7
Finishing	Black

### BPG Servomotor Technical Characteristics

For peak torque figures please refer to chapter 7 where the drive-motor associations are described.

BPG	Low Speed Continuous Torque	Rated Speed	Rotor Inertia		Motor Weight		Brake		Low Speed Continuous Current	Dimensioning Power
			Without Brake	With Brake	Without Brake	With Brake	Torque	Current		
	[Nm]	[rpm]	[g.m <sup>2</sup> ]	[g.m <sup>2</sup> ]	[kg]	[kg]	[Nm]	[A]	[Arms]	[kW]
0751N5...	1.3	3 000	0.25		4.0				2.2	0.41
0752N5...	2.3	3 000	0.30		4.8				2.7	0.72
0952N5...	4.3	3 000	0.86		7.6				3.5	1.35
0953N5...	6.0	3 000	0.97		8.9				5.2	1.88
1152N5...	7.4	3 000	2.45		11.2				5.5	2.32
1153K5...		2 000							5.3	2.20
1153N5...	10.5	3 000	2.73		13.3				9.2	3.30
1153V5...		6 000							12.6	6.60
1422N5...	12.0	3 000	6.70		20.4				10.4	3.77
1423N5...	17.0	3 000	7.30	-	23.3	-	-	-	11.7	5.34
1424K5...		2 000							10.4	4.61
1424R5...	22.0	4 250	7.90		26.2				20.8	9.79
1427N5...	35.0	3 000	9.70		34.9				24.2	11.00
1902K5...		2 000							16.6	5.24
1902N5...	25.0	3 000	20.90		38.1				19.9	7.85
1903K5...		2 000							19.7	7.54
1903N5...	36.0	3 000	22.90		43.3				27.8	11.31
1904N5...	46.0	3 000	24.80		48.6				30.3	14.45
1905L5...	56.0	2 500	26.80		53.6				31.4	14.66



### BPG Servomotor Ordering Codes

	BPG	075	1	N	5	Q	A	2	L	0	1
<b>Series</b>											
<b>Size</b> (075, 095, 115, 142, 190)											
<b>Length</b>											
<b>Winding type</b>											
<b>Fixed value</b>					5						
<b>Sensor type</b>											
<ul style="list-style-type: none"> <li>High resolution multi-turn encoder</li> <li>High resolution single-turn encoder</li> <li>Medium resolution multi-turn encoder</li> <li>Medium resolution single-turn encoder</li> </ul>						P					
						Q					
						J					
						K					
<b>Brake</b>											
<ul style="list-style-type: none"> <li>Brake not available</li> </ul>							A				
<b>Fixed value</b>								2			
<b>Shaft extension</b>											
<ul style="list-style-type: none"> <li>Smooth</li> <li>Keyed</li> </ul>									L		
									C		
<b>Fixed value</b>										0	
<b>Degree of protection (shaft extension/frame)</b>											
<ul style="list-style-type: none"> <li>IP 65/65</li> <li>IP 67/67 option</li> </ul>											1
											2



### BPH & BPG Servomotor Outlines

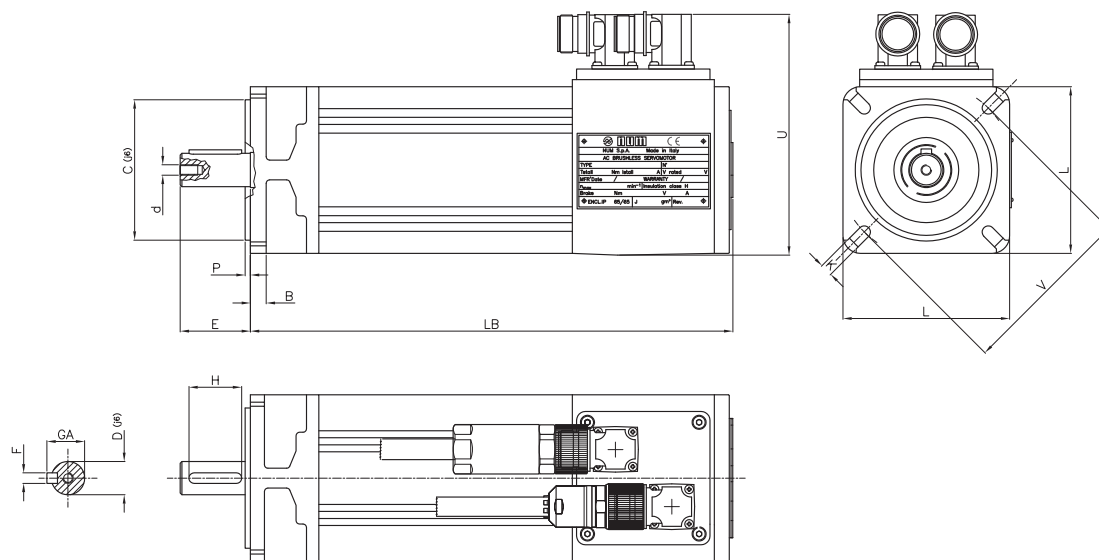

6

BPH BPG									BPH Shaft					BPG Shaft							
	L	LB <sup>3</sup>	C	P	B	V	K	U	D	E	H	F	GA	d	D	E	H	F	GA	d	
	[mm]	[mm]	[mm]	[mm]	[mm]	[mm]	[mm]	[mm]	[mm]	[mm]	[mm]	[mm]	[mm]	[mm]	[mm]	[mm]	[mm]	[mm]	[mm]	[mm]	
0751...		221							11	23	15	4	12.5	M4x10	14	30	20	5	16	M5x12	
0752...	75	250	60	2.5	8	75	6	117	14	30	20	5	16	M5x12							
0754...		308																			
0952...		275							19	40	30	6	21.5	M6x16	19	40	30	6	21.5	M6x16	
0953...	95	304	80	3	9	100	7	137													
0955...		362																			
1152...		290							19	40	30	6	21.5	M6x16	24	50	40	8	27	M8x19	
1153...	115	319	95	3	10	115	9	166													
1154...		348																			24
1156...		406																			
1422...		316							24	50	40	8	27	M8x19	32	58	46	10	35	M12x28	
1423...	142	345	130	3	14	165	11	193													
1424...		374																			32
1427...		461																			
1902...		355							32	58	45	10	35	M12x28	38	80	70	10	41	M12x28	
1903...		384																			
1904...	190	413	180	3	17	215	14	242 <sup>1</sup> or 258 <sup>2</sup>													
1905...		442																			
1907...		500																			
190A...		605																			38

<sup>1</sup> 190 2K. 2N. 3K. 4K. 5H

<sup>2</sup> 190 2R. 3N. 4N. 5L. 7K. AK

<sup>3</sup> BPH length doesn't change with or without brake



### BHL Servomotor General Characteristics

BHL servomotors are very compact high inertia units, designed for the feeding axes of large machine tools. They are available in one, 260 mm, frame size, with a variety of options.

General Motor Features	As per EN60034-1
Environment Storage Conditions • Temperature Range • Relative Humidity	-20 to +80 °C max. 80% without condensation
Environment Working Conditions • Temperature Range • Altitude	0 to 40 °C without derating, max. 55 °C with derating 0 to 1000 m without derating, max. 3000 m with derating
Continuous Stall Torque Range	From 85 to 160 Nm
Degree of protection as per EN60529	Housing IP65, shaft and fan IP54
Connection	Fanless version: connector Fan cooled version: terminal board
Permanent Magnet Holding Brake	24 VDC available as option
Motor Transducer	High resolution single turn and multi turn optical encoder
Mounting Restriction	No mounting restrictions, IMB5 - IMV1 - IMV3 as per EN60034-7
Finishing	Black

### BHL Servomotor Technical Characteristics

For peak torque figures please refer to chapter 7 where the drive-motor associations are described.

BHL	Low speed continuous torque	Rated speed	Rotor Inertia		Motor weight		Brake		Low speed continuous current	Dimensioning Power
			without brake	with brake	without brake	with brake	Torque	Current		
	[Nm]	[rpm]	[g.m <sup>2</sup> ]	[g.m <sup>2</sup> ]	[kg]	[kg]	[Nm]	[A]	[Arms]	[kW]
2601N5xx2...	85	3 000	45.0	48.1	95	99	80	1.5	52.0	26.70
2601N1xxV... <sup>1</sup>	120				100	104				
2602K5xx2...	120	2 000	66.2	69.3	126	130				
2602K1xxV... <sup>1</sup>	160				131	135				

<sup>1</sup> BHL motors with forced convection (V) require an auto-transformer for 480Vac network (code: AMOTRF001)





### BHL Servomotor Ordering Codes

	BHL	260	1	N	1	Q	A	2	L	0	5
<b>Series</b>											
<b>Size</b>											
<b>Length</b>											
<b>Winding type</b>											
<b>Power connection</b>											
• With terminal box mandatory for forced convection version						1					
• With power connector mandatory for natural convection version						5					
<b>Sensor type</b>											
• High resolution multi-turn encoder							P				
• High resolution single-turn encoder							Q				
<b>Brake</b>											
• Without brake								A			
• With brake								F			
<b>Cooling</b>											
• Natural convection									2		
• With fan (ventilated)									V		
<b>Shaft extension</b>											
• Smooth										L	
• Keyed										C	
<b>Fixed value</b>											0
<b>Degree of protection (shaft extension/frame/fan if present)</b>											
• IP 54/65/54											5

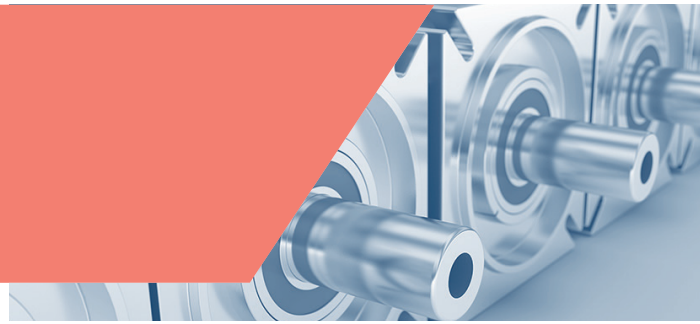

### BHL Servomotor Outlines

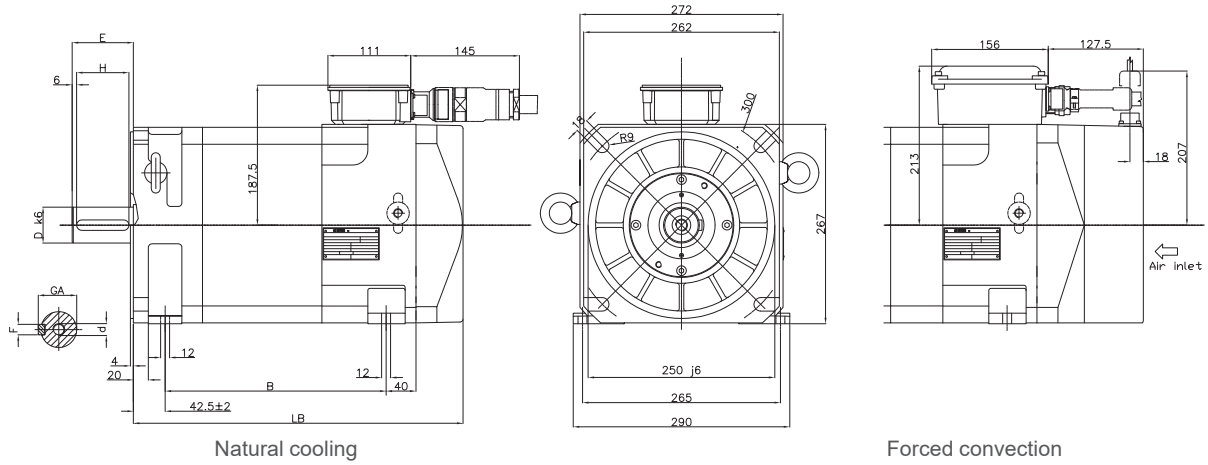

BHL	LB	B	D	E	H	F	GA	d
	[mm]	[mm]	[mm]	[mm]	[mm]	[mm]	[mm]	[mm]
2601x5xx2...	440	296 ± 2	48	82 ± 1	70	14	51.5	M16x36
2601x1xxV...	521	296 ± 2						
2602x5xx2...	510	366 ± 2						
2602x1xxV...	591							



### TMX Direct Drive Torque Motors General Characteristics

TMX are very compact torque motors for direct drive applications.

TMX motors are compatible with the major competitor's solutions providing very low cogging torque and very high S1 torque density.

Three motor diameter sizes are available in different lengths and additional sizes are being developed. If the existing motor range do not cover your needs, please get in touch with NUM.

Type of construction	IM 5110 (EN 60034-7)
Cooling	Liquid cooling (EN 60034-5)
Thermal motor protection	2 x KTY84 and PTC triplet
Maximum winding temperature	130°C
Stator insulation class	H (EN 60034-1; UL 1004; CSA 100)
Maximum inlet water temperature	25°C
Installation height above sea level	< 1000 m, then derating is needed
Supply voltage	3ph AC up to 480 Vrms
Electrical connections	cable with cable gland
Feedback system	not previewed
Mechanical architecture	Stator with steel cooling jacked + rotor sleeve with surface permanent magnets
Marking	CE



## TMX Direct Drive Torque Motors Technical Characteristics

For peak torque figures, please refer to chapter 7, where the drive-motor associations are described.

TMX	Low speed continuous torque <sup>1</sup>	Low speed continuous current <sup>1</sup>	Peak torque	Peak current	Maximum mechanical speed	Motor weight	
	[Nm]	[Arms]	[Nm]	[Arms]		[rpm]	Stator [kg]
TMX140050D..	33	6.5	57	19.5	1500	6.2	1.2
TMX140070C..	50	13	81	35	1500	8	1.6
TMX210050G..	124	12.6	250	34	500	8	2.5
TMX210070I..	174	12.6	350	34	500	11	3.5
TMX291050H..	230	18.5	435	53	500	16.6	3.4
TMX291070I..	325	23.5	610	65	500	21	5
TMX291150P..	705	22.8	1307	61	200	40	10.2

<sup>1</sup> Water cooling



### TMX Direct Drive Torque Motors Ordering Codes

	TMX	140	070	C	3	A	0	0	512
<b>Series</b>									
<b>Stator diameter</b>									
• 140 mm		140							
• 210 mm		210							
• 291 mm		291							
<b>Stator stack length</b>									
• 50 mm			050						
• 70 mm			070						
• 150 mm			150						
<b>Winding type</b>									
• Ke within 2.01 and 3.00 V*s/rad				C					
• Ke within 3.01 and 4.00 V*s/rad				D					
• Ke within 6.01 and 7.00 V*s/rad				G					
• Ke within 7.01 and 8.00 V*s/rad				H					
• Ke within 8.01 and 9.00 V*s/rad				I					
• Ke within 18.01 and 19.50 V*s/rad				P					
• Ke (values to be defined)				-					
<b>Cable type</b>									
• Cables with cable gland					3				
• Cables (3ph and thermal sensors) with 90° power cable gland <sup>1</sup>					7				
<b>Cable length</b>									
• 2 m						A			
<b>Type of supply</b>									
• Stator and rotor							0		
<b>Spare numbers</b>									
								0	
<b>Drawing number</b>									
• Last 3 digit of the outline drawing number									xxx

<sup>1</sup> Only available for TMX140



### TMX Direct Drive Torque Motors Outlines

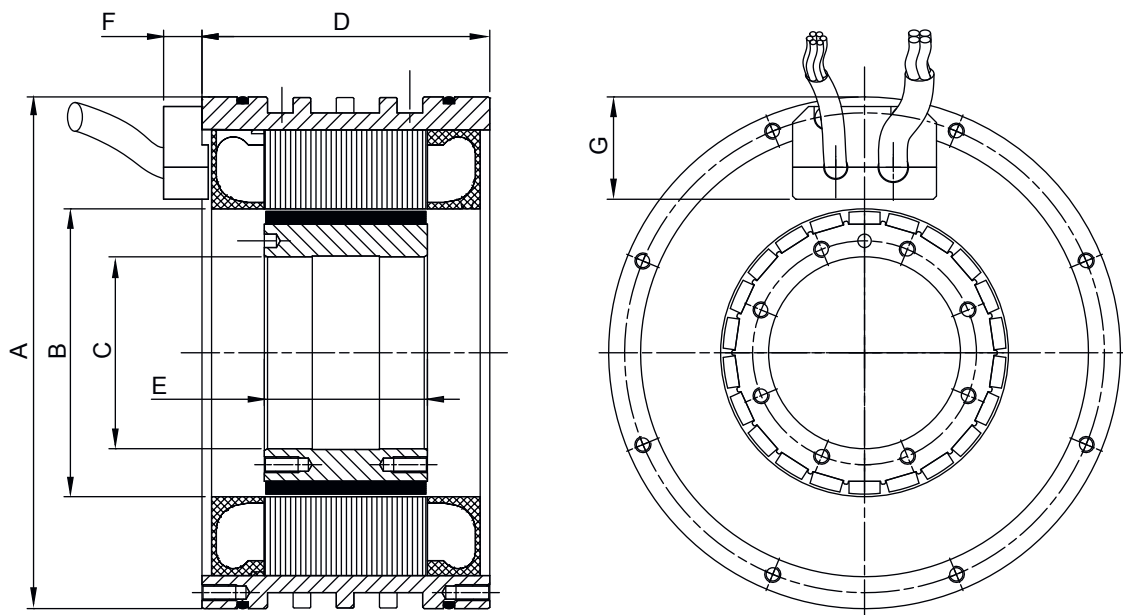

TMX	A	B	C	D	E	F	G
	[mm]	[mm]	[mm]	[mm]	[mm]	[mm]	[mm]
TMX140050..	160	90	60	90	51	12	32
TMX140070..	160	90	60	110	71	12	32
TMX210050..	230	170	140	90	51	12	29
TMX210070..	230	170	140	110	71	12	29
TMX291050..	310	230	200	100	51	12	36
TMX291070..	310	230	200	120	71	12	36
TMX291150..	310	230	200	200	151	12	36



## AMS & IM Spindlemotors General Characteristics

AMS asynchronous spindle motors incorporate a high resolution encoder and are capable of fast and accurate positioning, making them ideal for C axis control as well as spindle indexing applications. The motors are compact, have a low rotor inertia, and feature a built-in axial fan.

By using the flux vector control capabilities of NUMDrive modules, AMS spindle motors ensure very smooth rotation, even at low speeds.

Special versions of AMS spindle motors (size 132 and 160) are available for applications involving very high radial loads.

General Motor Features	As per EN60034-1
Environment Storage Conditions <ul style="list-style-type: none"> <li>• Temperature Range</li> <li>• Relative Humidity</li> </ul>	-20 to +80 °C max. 80% without condensation
Environment Working Conditions <ul style="list-style-type: none"> <li>• Temperature Range</li> <li>• Altitude</li> </ul>	0 to 40 °C without derating, max. 55 °C with derating 0 to 1000 m without derating, max. 3000 m with derating
Rated Power	From 3.7 up to 55 kW
Degree of Protection as per EN60529	IP65 for the housing IP54 for the fan IP54 for the shaft, optionally IP65
Connection	By terminal board for the power By connector for the encoder
Motor Transducer	High resolution single turn and multi turn optical encoder
Mounting Restriction	No mounting restrictions, IMB5 - IMV1 - IMV3 as per EN60034-7
Vibration Class as per EN60034-14	R class, optionally S class
Fan Input Voltage	400 VAC ± 5% 3 phases, 50/60 Hz (AMS motors) 220 VAC ± 5% 1 phase, 50/60 Hz (IM motors)



## AMS Spindlemotors Technical Characteristics

For power figures please refer to chapter 7 where the drive-motor associations are described.

AMS	Connection	Rated Continuous Power	Rated Speed	Max Speed	Rated Torque	Rated Continuous Current	Rotor Inertia	Fan (3 Phases)		Motor Weight			
								Voltage	Current				
		[kW]	[rpm]	[rpm]	[Nm]	[Arms]	[g.m <sup>2</sup> ]	[V]	[Arms]	[Kg]			
100SB1...	Y	3.7	1500	6500	24	20	9	400	0.11	37			
100MB1...	Y	5.5			35	26	14			49			
100GB1...	Y	9.0			57	39	23			71			
100SD1...	Y	3.7		12000	24	20	9			37			
100MD1...	Y	5.5			35	26	14			49			
100GD1...	Y	9.0			57	39	23			71			
132SA1...	Y	5.0	750	7000	64	26	55		0.20	105			
132SC1...	Y	10.0	1500		64	39					105		
132SE1...	Δ	15.0	1750		82	52					105		
132MA1...	Y	7.5	750		75	95	39			131			
132MC1...	Y	15.0	1500			95	52				131		
132ME1...	Δ	19.5	2000			100	72				131		
132LA1...	Y	11.0	750		10000	140	52			113	0.20	183	
132LE1...	Y	22.0	1250			168	72						183
132SF1...	Y	5.0	750			55	64						26
132SG1...	Y	10.0	1500				64			39		105	
132SH1...	Δ	15.0	1750				82			52		105	
132MF1...	Y	7.5	750			75	95			39		131	
132MG1...	Y	15.0	1500	95	52		131						
132MH1...	Δ	19.5	2000	93	72		131						
132LF1...	Y	11.0	750	9000	140	52	113	0.20	183				
132LI1...	Y	12.5	680		175	39				183			
132LH1...	Y	22.0	1250		168	72				183			
160MA1...	Y	18.0	650	8500	264	52	250	0.30	215				
	Δ		1300		132					215			
160MB1...	Y	26.0	1200		208	72				215			
	Δ		2400								104	215	
160MC1...	Δ	36.0	1700		202	100				215			
160LA1...	Y	18.0	500		6500	344				52	370	0.30	290
	Δ		1000	172		290							
160LB1...	Y	26.0	950	260		72	290						
	Δ		1900						130	290			
160LC1...	Δ	36.0	1050	328		100	290						





## IM Spindlemotors Technical Characteristics

For power figures please refer to chapter 7 where the drive-motor associations are described.

IM	Connec- tion Type	Rated Conti- nuous Power	Rated Speed	Max Speed	Rated Torque	Rated Conti- nuous Current	Rotor Inertia	Fan (1 Phase)		Motor Weight	
		[kW]	[rpm]	[rpm]	[Nm]	[Arms]		[g.m <sup>2</sup> ]	Voltage		Current
		[V]	[Arms]	[Kg]							
18MK14...	YY	55	1050	7500	500	145	570	230	0.8	415	

## AMS Spindle Motor Ordering Codes

	AMS	100	S	B	1	Q	22	L	R	0
<b>Series</b>										
<b>Size</b> (100, 132, 160)										
<b>Length</b>										
<b>Winding type</b>										
<b>Fixed value</b>					1					
<b>Sensor type</b>						P				
• High resolution multi-turn encoder						Q				
• High resolution single-turn encoder										
<b>Fixed value</b>							22			
<b>Shaft extension</b>								L		
• Smooth								C		
• Keyed										
<b>Vibration class</b>									R	
• Class R									S	
• Class S										
<b>Degree of protection (shaft extension/frame/fan) and radial load</b>										
• IP 54/65/54 with standard permissible radial load										0
• IP 65/65/54 with standard permissible radial load										1
• IP 54/65/54 with high permissible radial load (just for size 132 and 160)										2
• IP 65/65/54 with high permissible radial load (just for size 132 and 160)										3



### IM Spindle Motor Ordering Codes

	IM	18	M	K14	C	Q	22	L	R	0
<b>Series</b>										
<b>Size</b>										
<b>Length</b>										
<b>Winding type</b>										
<b>Fixed value</b>					C					
<b>Sensor type</b>						P				
<ul style="list-style-type: none"> <li>High resolution multi-turn encoder</li> <li>High resolution single-turn encoder</li> </ul>						Q				
<b>Fixed value</b>							22			
<b>Shaft extension</b>								L		
<ul style="list-style-type: none"> <li>Smooth</li> <li>Keyed</li> </ul>								C		
<b>Vibration class</b>										
<ul style="list-style-type: none"> <li>Class R</li> <li>Class S</li> </ul>									R	
										S
<b>Degree of protection (shaft extension)</b>										
<ul style="list-style-type: none"> <li>IP 54</li> <li>IP 65</li> </ul>										0
										1



### AMS Spindle Motor Outlines

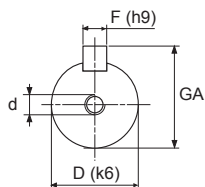

AMS 100 Motor

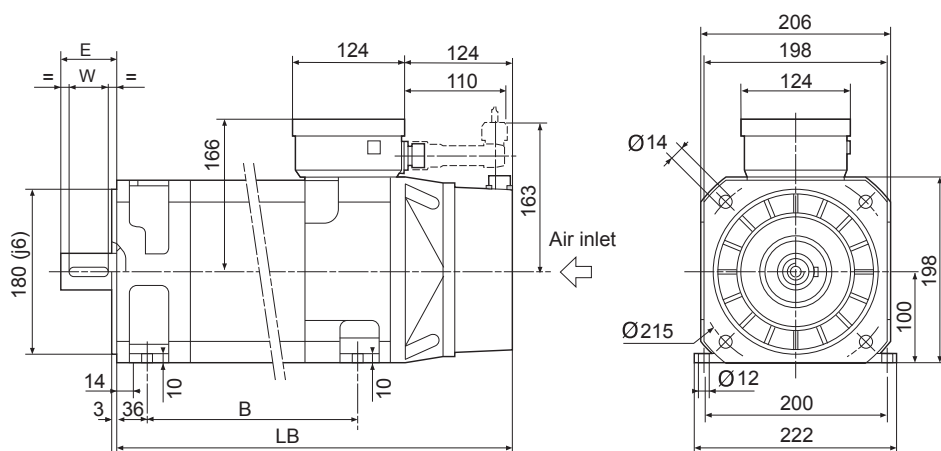

AMS 132 Motor

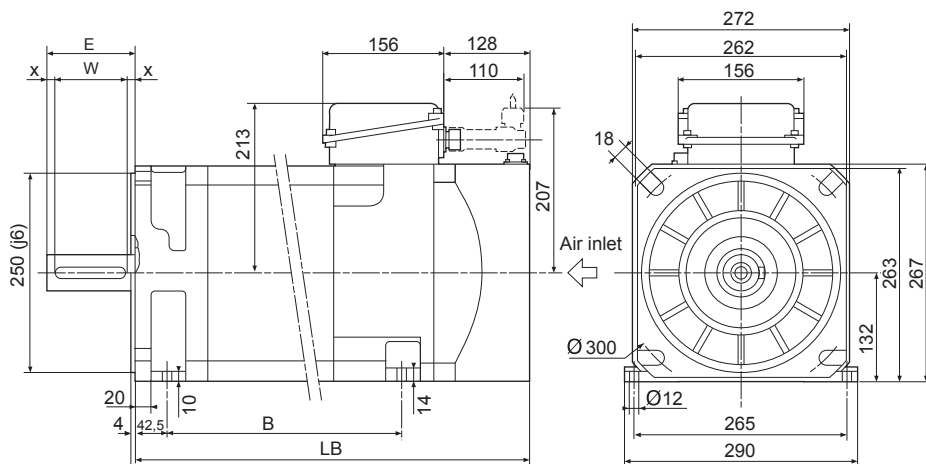

All dimensions in mm

	LB	B	Shaft					
			D	E	W	F	GA	d
	[mm]	[mm]	[mm]	[mm]	[mm]	[mm]	[mm]	[mm]
100 S	388	179 ± 1.5	32	60	50	10	35	M12x30
100 M	442	233 ± 1.5						
100 G	535	326 ± 1.5						
132 S	521	296 ± 2	42	110	90	12	45	
132 M	591	366 ± 2						
132 L	721	496 ± 2						



### AMS Spindle Motor Outlines

AMS 160 Motor

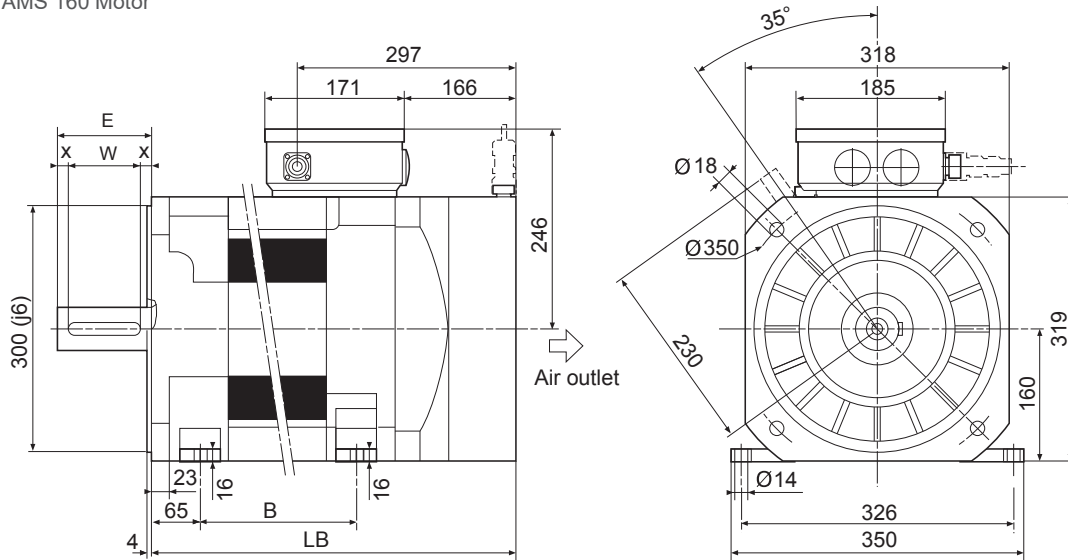

	Shaft							
	LB	B	D	E	W	F	GA	d
	[mm]	[mm]	[mm]	[mm]	[mm]	[mm]	[mm]	[mm]
160 M	682	385 ± 2	55	110	90	16	59	M20x42
160 L	827	530 ± 2						

### IM Spindle Motor Outlines

IM 18MK14 Motor

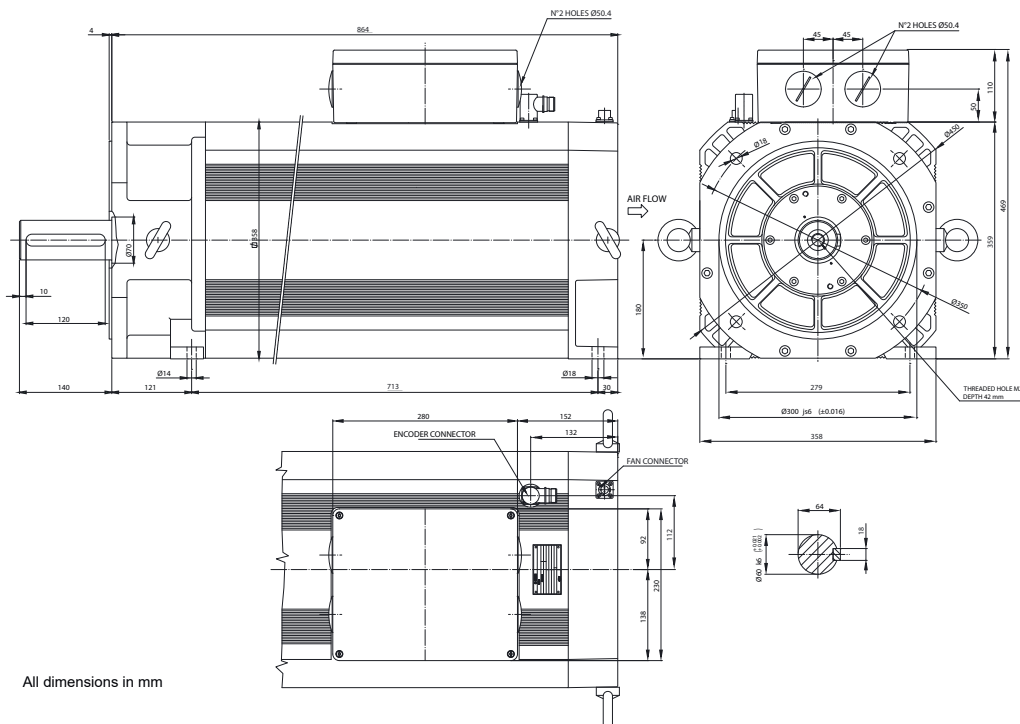

All dimensions in mm

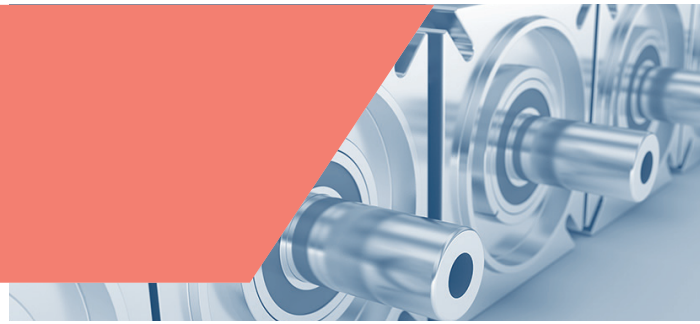

### Encoder Characteristics

All NUM motors are equipped with an encoder to provide feedback on the angular position of the rotor for phase switching. The position information is also used to close the controller's position and speed control loops.

Users can choose the type of encoder to suit their application needs, subject to the type of motor and functional safety requirements, as shown in the table below:

Sin/Cos Encoders	Technical Characteristics			
	Encoder P	Encoder Q	Encoder J	Encoder K
Sensor Type	High Resolution Multi-Turn	High Resolution Single-Turn	Medium Resolution Multi-Turn	Medium Resolution Single-Turn
Precision	< ±45 arcseconds		< ±80 arcseconds	
Operating Temperature Range	-40°C / +125°C			
Supply Voltage	7V - 12V			
Resolution per Turn	1024	1024	128	128
Turns	4096	1	4096	1
Electrical Interface	1Vpp SinCos + Hiperface			

6

Encoders for Single Cable Motor (SHX/SPX)	Technical Characteristics			
	Encoder Y	Encoder Z	Encoder I	Encoder L
Sensor Type	High Resolution Multi-Turn	High Resolution Single-Turn	Medium Resolution Multi-Turn	Medium Resolution Single-Turn
Precision	< ±25 arcseconds		< ±60 arcseconds	
Operating Temperature Range	-20°C / +115°C			
Supply Voltage	7V - 12V			
Measurement Step per Revolution	16777216 (24 bits)		1048576 (20 bits)	
Turns	4096	1	4096	1
Electrical Interface	Fast serial 2-wire protocol			
Functional Safety	no			
Other Info	Motor thermal probe information integrated in the encoder protocol (no need of cabling)			

The implementation of safety functions when using FlexiumPro/NUM DrivePro systems does not require the usage of SIL encoders. See NUM-SAMX manual for details.



### NUM Custom Motors

As well as the standard motors described on preceding pages, NUM designs and manufactures special motors and built-in (Motorspindle) motors to suit customers' specific needs.

For information about special or built-in motors, please contact your local NUM sales office.



Motorspindle®: stator elements, synchronous and asynchronous technology, for integration in electro spindles.



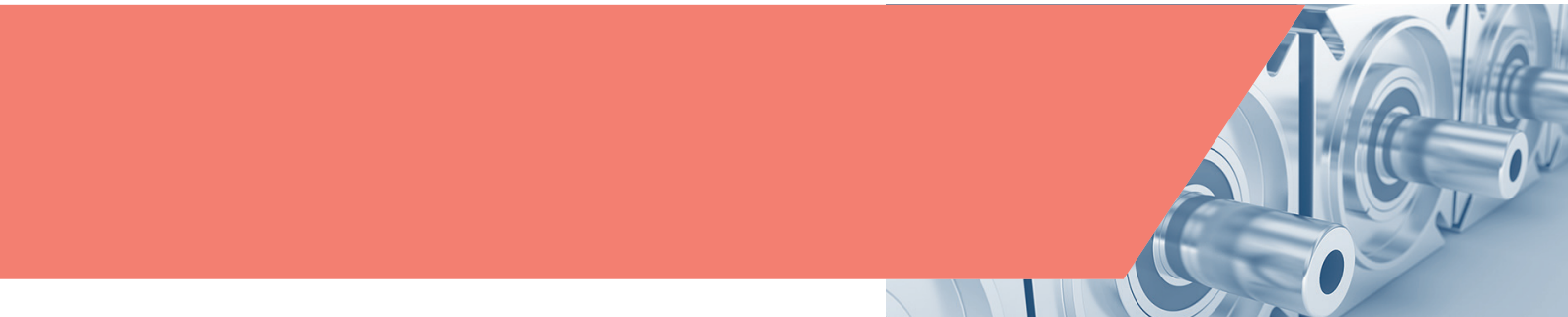

# Motor/Drive Associations

## Servomotors

### Association of BHX & SHX Motors with NUM DrivePro



#### Association of BHX & SHX Motors with NUM DrivePro (Switching Frequency 5 kHz)

BHX SHX	MDLUF....		007B	007A	014B 014D	014A	021B	021A	034A	050B	050A	075B	075A	100A	150A	200A	400A
	Rated speed	Low speed contin. torque	Peak torque	Peak torque	Peak torque	Peak torque	Peak torque	Peak torque	Peak torque	Peak torque	Peak torque	Peak torque	Peak torque	Peak torque	Peak torque	Peak torque	Peak torque
	[rpm]	[Nm]	[Nm]	[Nm]	[Nm]	[Nm]	[Nm]	[Nm]	[Nm]	[Nm]	[Nm]	[Nm]	[Nm]	[Nm]	[Nm]	[Nm]	[Nm]
0751V5...	6 000	1.2	3.5	3.5	4.3	4.3	4.3										
0752V5...	6 000	2.1	3.4	3.4	6.6	6.6	7.8	7.8		7.8							
0951V5...	6 000	2.4	4	4	6.4	6.4	7.5	7.5		7.5							
0952N5...	3 000	4.3	7.7	7.7	13.2	13.2	14.5	14.5		14.5							
0952V5...	6 000				7.8	7.8	10.5	10.5	14.5	14.5		14.5					
1261N5...	3 000	4.5	7	7	11.5	11.5	13	13		13							
1261V5...	6 000				7	7	9.5	9.5	12.4	13							
1262N5...	3 000	8.4			13.8	13.8	20	20	27	27		27					
1262V5...	6 000								10.5	16	22	22	27	27			
1263R5...	4 500	11						16.5	25	34	34	37					
1552N5...	3 000	12			16	16	23	23	33	39	39	39					
1552R5...	4 500								17	26.5	35	35	39				
1554N5...	3 000	20						24	38	53	53	69	69				

#### Association of BHX & SHX Motors with NUM DrivePro (Switching Frequency 10 kHz)

BHX SHX	MDLUF....		007B	007A	014B 014D	014A	021B	021A	034A	050B	050A	075B	075A	100A	150A	200A	400A
	Rated speed	Low speed contin. torque	Peak torque	Peak torque	Peak torque	Peak torque	Peak torque	Peak torque	Peak torque	Peak torque	Peak torque	Peak torque	Peak torque	Peak torque	Peak torque	Peak torque	Peak torque
	[rpm]	[Nm]	[Nm]	[Nm]	[Nm]	[Nm]	[Nm]	[Nm]	[Nm]	[Nm]	[Nm]	[Nm]	[Nm]	[Nm]	[Nm]	[Nm]	[Nm]
0751V5...	6 000	1.2	3.5	3.5	4.3	4.3	4.3										
0752V5...	6 000	2.1	3.4	3.4	6.6	6.6	7.8	7.8		7.8							
0951V5...	6 000	2.4	4	4	6.4	6.4	7.5	7.5		7.5							
0952N5...	3 000	4.3	7.7	7.7	13.2	13.2	14.5	14.5		14.5							
0952V5...	6 000				7.8	7.8	10.5	10.5	14.5	14.5		14.5					
1261N5...	3 000	4.5	7	7	11.5	11.5	13	13		13							
1261V5...	6 000								9.5	12.4	13	13	13				
1262N5...	3 000	8.4			13.8	13.8	20	20	27	27							
1262V5...	6 000										22	22	27	27			
1263R5...	4 500	11								34	34	37					
1552N5...	3 000	12						23	33	39	39	39					
1552R5...	4 500										35	35	39	39			
1554N5...	3 000	20								53	53	69	69				

In case the motor is associated to a Bi-Axes or Quad-Axes drive, the motor's low speed contin. torque depends on which motor type is connected at the same power unit.



# Motor/Drive Associations

## Servomotors

### Association of BPX & SPX Motors with NUM DrivePro



#### Association of BPX & SPX Motors with NUM DrivePro (Switching Frequency 5 kHz)

BPX SPX	MDLUF....		007B	007A	014B 014D	014A	021B	021A	034A	050B	050A	075B	075A	100A	150A	200A	400A
	Rated speed	Low speed contin. torque	Peak torque	Peak torque	Peak torque	Peak torque	Peak torque	Peak torque	Peak torque	Peak torque	Peak torque	Peak torque	Peak torque	Peak torque	Peak torque	Peak torque	Peak torque
	[rpm]	[Nm]	[Nm]	[Nm]	[Nm]	[Nm]	[Nm]	[Nm]	[Nm]	[Nm]	[Nm]	[Nm]	[Nm]	[Nm]	[Nm]	[Nm]	[Nm]
0551V5... <sup>1</sup>	6 000	0.5	1.5	1.5	1.5												
0751V5...	6 000	1.4	3.5	3.5	4.3	4.3	4.3										
0752V5...	6 000	2.3	3.4	3.4	6.6	6.6	7.8	7.8		7.8							
0951V5...	6 000	2.7	4	4	6.4	6.4	7.5	7.5		7.5							
0952N5...	3 000	5	7.7	7.7	13.2	13.2	14.5	14.5		14.5							
0952V5...	6 000				7.8	7.8	10.5	10.5	14.5	14.5		14.5					
1261N5...	3 000	5.2	7	7	11.5	11.5	13	13		13							
1261V5...	6 000				7	7	9.5	9.5	12.4	13		13					
1262N5...	3 000	9.8			13.8	13.8	20	20	27	27		27					
1262V5...	6 000									22	22	27	27				
1263R5...	4 500	12.6						16.5	25	34	34	37					
1552N5...	3 000	13.8					16	23	23	33	39	39					
1552R5...	4 500								17	26.5	35	35	39				
1554N5...	3 000	23								53	53	69	69				

7

#### Association of BPX & SPX Motors with NUM DrivePro (Switching Frequency 10 kHz)

BPX SPX	MDLUF....		007B	007A	014B 014D	014A	021B	021A	034A	050B	050A	075B	075A	100A	150A	200A	400A
	Rated speed	Low speed contin. torque	Peak torque	Peak torque	Peak torque	Peak torque	Peak torque	Peak torque	Peak torque	Peak torque	Peak torque	Peak torque	Peak torque	Peak torque	Peak torque	Peak torque	Peak torque
	[rpm]	[Nm]	[Nm]	[Nm]	[Nm]	[Nm]	[Nm]	[Nm]	[Nm]	[Nm]	[Nm]	[Nm]	[Nm]	[Nm]	[Nm]	[Nm]	[Nm]
0551V5... <sup>1</sup>	6 000	0.5	1.5	1.5													
0751V5...	6 000	1.4	3.5	3.5	4.3	4.3	4.3										
0752V5...	6 000	2.3	3.4	3.4	6.6	6.6	7.8	7.8		7.8							
0951V5...	6 000	2.7	4	4	6.4	6.4	7.5	7.5		7.5							
0952N5...	3 000	5	7.7	7.7	13.2	13.2	14.5	14.5		14.5							
0952V5...	6 000							10.5	14.5	14.5		14.5					
1261N5...	3 000	5.2	7	7	11.5	11.5	13	13		13							
1261V5...	6 000							9.5	12.4	13	13	13					
1262N5...	3 000	9.8					20	20	27	27		27					
1262V5...	6 000									22	22	27	27				
1263R5...	4 500	12.6								34	34	37					
1552N5...	3 000	13.8								39	39	39					
1552R5...	4 500									35	35	39	39				
1554N5...	3 000	23								53	53	69	69				

<sup>1</sup> Available as BPX only

In case the motor is associated to a Bi-Axes or Quad-Axes drive, the motor's low speed contin. torque depends on which motor type is connected at the same power unit.

# Motor/Drive Associations

## Servomotors

### Association of BPH Motors with NUM DrivePro



### Association of BPH Motors with NUM DrivePro (Switching Frequency 5 kHz)

MDLUF...			007B	007A	014B 014D	014A	021B	021A	034A	050B	050A	075B	075A	100A	150A	200A	400A
BPH	Rated speed	Low speed contin. torque	Peak torque	Peak torque	Peak torque	Peak torque	Peak torque	Peak torque	Peak torque	Peak torque	Peak torque	Peak torque	Peak torque	Peak torque	Peak torque	Peak torque	Peak torque
	[rpm]	[Nm]	[Nm]	[Nm]	[Nm]	[Nm]	[Nm]	[Nm]	[Nm]	[Nm]	[Nm]	[Nm]	[Nm]	[Nm]	[Nm]	[Nm]	[Nm]
0751N5...	3 000	1.3			4.8	4.8	4.8										
0751V5...	6 000				3.9	3.9	3.9				3.9						
0752N5...	3 000	2.3			7.5	7.5	7.5					7.5					
0752V5...	6 000				5.9	5.9	5.9				5.9						
0754N5...	3 000	4			11	11	11					11					
0952N5...	3 000	4.3			11	11	11					11					
0952V5...	6 000				7.2	7.2	10	10			10		10				
0953N5...	3 000	6			11.2	11.2	16	16				16					
0953V5...	6 000									14	14	14	14				
0955N5...	3 000	9.2			15.7	15.7	22	22				22					
1152N5...	3 000	7.4			11.9	11.9	16	16				16					
1152V5...	6 000									14	14	14	14				
1153K5...	2 000	10.5			17.2	17.2	24	24				24					
1153N5...	3 000									22	22	22	22				
1153V5...	6 000								18	18	18	18					
1154K5...	2 000	13.3			19.8	19.8	27	27				27					
1154N5...	3 000									27	27	27	27				
1154V5...	6 000									23	23	23					
1156N5...	3 000	18.7								33	33	33	33				
1422K5...	2 000	12			19.2	19.2	22	22				22					
1422N5...	3 000									20	27	27	31				
1422R5...	4 250								19	19	19	19					
1423K5...	2 000	17								33	33	33	33				
1423N5...	3 000									28	28	28	28				
1423R5...	4 250									28	28	28					
1424K5...	2 000	22								41	41	41	41				
1424N5...	3 000										41	41	41				
1424R5...	4 250											45	45				
1427N5...	3 000	35										71	71				
1902K5...	2 000	25									40	40	40				
1902N5...	3 000											35	35	35	35		
1902R5...	4 250											36	36	36			
1903K5...	2 000	36									52	52	52	52			
1903N5...	3 000												54	54	54		
1904K5...	2 000	46										90	90				
1904N5...	3 000												69	69	69		
1905H5...	1 500	56									82	82	82	82			
1905L5...	2 500												79	79	79		
1907K5...	2 000	75										120	120	120			
1907N5...	3 000															125	125
190AK5...	2 000	100												145		145	

In case the motor is associated to a Bi-Axes or Quad-Axes drive, the motor's low speed cont. torque depends on which motor type is connected at the same power unit.

# Motor/Drive Associations

## Servomotors

### Association of BPH Motors with NUM DrivePro



#### Association of BPH Motors with NUM DrivePro (Switching Frequency 10 kHz)

BPH	MDLUF...		007B	007A	014B 014D	014A	021B	021A	034A	050B	050A	075B	075A	100A	150A	200A	400A
	Rated speed	Low speed contin. torque	Peak torque	Peak torque	Peak torque	Peak torque	Peak torque	Peak torque	Peak torque	Peak torque	Peak torque	Peak torque	Peak torque	Peak torque	Peak torque	Peak torque	Peak torque
	[rpm]	[Nm]	[Nm]	[Nm]	[Nm]	[Nm]	[Nm]	[Nm]	[Nm]	[Nm]	[Nm]	[Nm]	[Nm]	[Nm]	[Nm]	[Nm]	[Nm]
0751N5...	3 000	1.3			4.8	4.8	4.8										
0751V5...	6 000				3.9	3.9	3.9			3.9							
0752N5...	3 000	2.3			7.5	7.5	7.5			7.5							
0752V5...	6 000				5.9	5.9	5.9			5.9							
0754N5...	3 000	4			11	11	11			11							
0952N5...	3 000	4.3			11	11	11			11							
0952V5...	6 000				7.2	7.2	10	10		10		10					
0953N5...	3 000	6			11.2	11.2	16	16		16		16					
0953V5...	6 000									14	14	14					
0955N5...	3 000	9.2			15.7	15.7	22	22		22		22					
1152N5...	3 000	7.4			11.9	11.9	16	16		16		16					
1152V5...	6 000									14	14	14					
1153K5...	2 000	10.5			17.2	17.2	24	24		24		24					
1153N5...	3 000									22	22	22					
1153V5...	6 000									18	18	18					
1154K5...	2 000	13.3						27		27		27					
1154N5...	3 000									27	27	27					
1154V5...	6 000									23	23	23					
1156N5...	3 000	18.7								33	33	33					
1422K5...	2 000	12			19.2	19.2	22	22		22		22					
1422N5...	3 000									27	27	31					
1422R5...	4 250									19	19	19					
1423K5...	2 000	17								33	33	33					
1423N5...	3 000									28	28	28					
1423R5...	4 250									28	28	28					
1424K5...	2 000	22								41	41	41					
1424N5...	3 000									41	41	41					
1424R5...	4 250											45	45				
1427N5...	3 000	35									71			71			
1902K5...	2 000	25								40	40	40					
1902N5...	3 000											35	35				
1902R5...	4 250														36		
1903K5...	2 000	36										52	52				
1903N5...	3 000												54		54		
1904K5...	2 000	46										90	90				
1904N5...	3 000														69		
1905H5...	1 500	56										82	82				
1905L5...	2 500															79	
1907K5...	2 000	75										120		120			
1907N5...	3 000																125
190AK5...	2 000	100															145

In case the motor is associated to a Bi-Axes or Quad-Axes drive, the motor's low speed contin. torque depends on which motor type is connected at the same power unit.

# Motor/Drive Associations

## Servomotors

### Association of BPG Motors with NUM DrivePro



#### Association of BPG Motors with NUM DrivePro (Switching Frequency 5 kHz)

BPG	MDLUF...		007B	007A	014B 014D	014A	021B	021A	034A	050B	050A	075B	075A	100A	150A	200A	400A
	Rated speed	Low speed contin. torque	Peak torque	Peak torque	Peak torque	Peak torque	Peak torque	Peak torque	Peak torque	Peak torque	Peak torque	Peak torque	Peak torque	Peak torque	Peak torque	Peak torque	Peak torque
	[rpm]	[Nm]	[Nm]	[Nm]	[Nm]	[Nm]	[Nm]	[Nm]	[Nm]	[Nm]	[Nm]	[Nm]	[Nm]	[Nm]	[Nm]	[Nm]	[Nm]
0751N5...	3 000	1.3			4.8	4.8	4.8										
0752N5...	3 000	2.3			7.5	7.5	7.5			7.5							
0952N5...	3 000	4.3			11	11	11			11							
0953N5...	3 000	6			11.2	11.2	16	16		16		16					
1152N5...	3 000	7.4			11.9	11.9	16	16		16		16					
1153K5...	2 000	10.5			17.2	17.2	24	24		24		24					
1153N5...	3 000								22	22	22	22					
1153V5...	6 000								18	18	18	18					
1422N5...	3 000	12							20	31	31	31					
1423N5...	3 000	17							28	28	28	28					
1424K5...	2 000	22							41	41	41	41					
1424R5...	4 250											45	45				
1427N5...	3 000	35										71	71				
1902K5...	2 000	25								40	40	40					
1902N5...	3 000									35	35	35	35				
1903K5...	2 000	36								52	52	52	52				
1903N5...	3 000											54	54	54			
1904N5...	3 000	46										69	69	69			
1905L5...	2 500	56										79	79	79			

In case the motor is associated to a Bi-Axes or Quad-Axes drive, the motor's low speed contin. torque depends on which motor type is connected at the same power unit.

# Motor/Drive Associations

## Servomotors

### Association of BPG Motors with NUM DrivePro



#### Association of BPG Motors with NUM DrivePro (Switching Frequency 10 kHz)

BPG	MDLUF...		007B	007A	014B 014D	014A	021B	021A	034A	050B	050A	075B	075A	100A	150A	200A	400A
	Rated speed	Low speed contin. torque	Peak torque	Peak torque	Peak torque	Peak torque	Peak torque	Peak torque	Peak torque	Peak torque	Peak torque	Peak torque	Peak torque	Peak torque	Peak torque	Peak torque	Peak torque
	[rpm]	[Nm]	[Nm]	[Nm]	[Nm]	[Nm]	[Nm]	[Nm]	[Nm]	[Nm]	[Nm]	[Nm]	[Nm]	[Nm]	[Nm]	[Nm]	[Nm]
0751N5...	3 000	1.3			4.8	4.8	4.8										
0752N5...	3 000	2.3			7.5	7.5	7.5			7.5							
0952N5...	3 000	4.3			11	11	11			11							
0953N5...	3 000	6			11.2	11.2	16	16		16		16					
1152N5...	3 000	7.4			11.9	11.9	16	16		16		16					
1153K5...	2 000	10.5			17.2	17.2	24	24		24		24					
1153N5...	3 000									22	22	22					
1153V5...	6 000									18	18	18					
1422N5...	3 000	12								27	27	31					
1423N5...	3 000	17								28	28	28					
1424K5...	2 000	22								41	41	41					
1424R5...	4 250											45	45				
1427N5...	3 000	35										71		71			
1902K5...	2 000	25								40	40	40					
1902N5...	3 000											35	35				
1903K5...	2 000	36										52	52				
1903N5...	3 000												54		54		
1904N5...	3 000	46												69			
1905L5...	2 500	56												79			

7

In case the motor is associated to a Bi-Axes or Quad-Axes drive, the motor's low speed contin. torque depends on which motor type is connected at the same power unit.

# Motor/Drive Associations

## Servomotors

### Association of BHL Motors with NUM DrivePro



#### Association of BHL Motors with NUM DrivePro (Switching Frequency 5 kHz)

MDLUF...			007B	007A	014B 014D	014A	021B	021A	034A	050B	050A	075B	075A	100A	150A	200A	400A	
BHL	Rated speed	Low speed contin. torque	Peak torque	Peak torque	Peak torque	Peak torque	Peak torque	Peak torque	Peak torque	Peak torque	Peak torque	Peak torque	Peak torque	Peak torque	Peak torque	Peak torque	Peak torque	
	[rpm]	[Nm]	[Nm]	[Nm]	[Nm]	[Nm]	[Nm]	[Nm]	[Nm]	[Nm]	[Nm]	[Nm]	[Nm]	[Nm]	[Nm]	[Nm]	[Nm]	
2601N5xx2...	3000	85														165	210	
2601N1xxV...		120																210
2602K5xx2...	2000	120														230	290	
2602K1xxV...		160																290

#### Association of BHL Motors with NUM DrivePro (Switching Frequency 10 kHz)

MDLUF...			007B	007A	014B 014D	014A	021B	021A	034A	050B	050A	075B	075A	100A	150A	200A	400A		
BHL	Rated speed	Low speed contin. torque	Peak torque	Peak torque	Peak torque	Peak torque	Peak torque	Peak torque	Peak torque	Peak torque	Peak torque	Peak torque	Peak torque	Peak torque	Peak torque	Peak torque	Peak torque		
	[rpm]	[Nm]	[Nm]	[Nm]	[Nm]	[Nm]	[Nm]	[Nm]	[Nm]	[Nm]	[Nm]	[Nm]	[Nm]	[Nm]	[Nm]	[Nm]	[Nm]		
2601N5xx2...	3000	85															210		
2601N1xxV...		112																210	
2602K5xx2...	2000	120																290	
2602K1xxV...		160																	290

V = Ventilated version

# Motor/Drive Associations

## Servomotors

### Association of TMX Motors with NUM DrivePro



#### Association of TMX Motors with NUM DrivePro (Switching Frequency 5 kHz)

TMX	MDLUF....		007B	007A	014B 014D	014A	021B	021A	034A	050B	050A	075B	075A	100A	150A	200A	400A
	Rated speed	Low speed contin. torque	Peak torque	Peak torque	Peak torque	Peak torque	Peak torque	Peak torque	Peak torque	Peak torque	Peak torque	Peak torque	Peak torque	Peak torque	Peak torque	Peak torque	Peak torque
	[rpm]	[Nm]	[Nm]	[Nm]	[Nm]	[Nm]	[Nm]	[Nm]	[Nm]	[Nm]	[Nm]	[Nm]	[Nm]	[Nm]	[Nm]	[Nm]	[Nm]
TMX140050D.. Water cooled	1500	33			43	43	51	51	57	57							
TMX140070C.. Water cooled	1500	50							70	81	81	81					
TMX210050G.. Water cooled	500	124							203	250	250	250					
TMX210070I.. Water cooled	500	174							285	350	350	350					
TMX291050H.. Water cooled	500	230								360	360	435	435				
TMX291070I.. Water cooled	500	325								442	442	560	560	610			
TMX291150P.. Water cooled	200	705								947	947	1193	1193	1307			

7

#### Association of TMX Motors with NUM DrivePro (Switching Frequency 10 kHz)

TMX	MDLUF....		007B	007A	014B 014D	014A	021B	021A	034A	050B	050A	075B	075A	100A	150A	200A	400A
	Rated speed	Low speed contin. torque	Peak torque	Peak torque	Peak torque	Peak torque	Peak torque	Peak torque	Peak torque	Peak torque	Peak torque	Peak torque	Peak torque	Peak torque	Peak torque	Peak torque	Peak torque
	[rpm]	[Nm]	[Nm]	[Nm]	[Nm]	[Nm]	[Nm]	[Nm]	[Nm]	[Nm]	[Nm]	[Nm]	[Nm]	[Nm]	[Nm]	[Nm]	[Nm]
TMX140050D.. Water cooled	1500	33						51	57	57							
TMX140070C.. Water cooled	1500	50								81	81	81					
TMX210050G.. Water cooled	500	124							203	250	250	250					
TMX210070I.. Water cooled	500	174								350	350	350					
TMX291050H.. Water cooled	500	230								360	360	435	435				
TMX291070I.. Water cooled	500	325										560	560	610			
TMX291150P.. Water cooled	200	705										1193	1193	1307			



### General Description

AMS Motor Power vs Speed and Torque vs Speed Characteristics

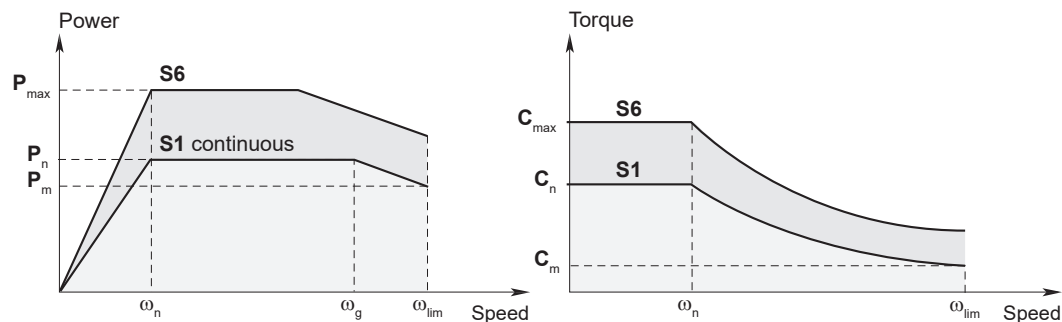

- $P_n$  = Rated continuous power (S1)
- $P_{max}$  = Overload power (S6)
- $P_m$  = Continuous power at maximum speed (S1)
- $\omega_n$  = Rated speed
- $C_n$  = Rated torque
- $C_{max}$  = Overload torque (S6)
- $C_m$  = Continuous torque at maximum speed (S1)
- $\omega_g$  = Maximum speed at constant power (S1)
- $\omega_{lim}$  = Maximum speed
- $I_{cont}$  = Rated continuous current (S1)
- $I_{ms}$  = Overload current with the associated drive (S6)

### Services

	S2	S3	S6
Load			
Electrical losses			
Temperature			
Time	—	$f_m = \frac{N}{N+R} \times 100 (\%)$	$f_m = \frac{N}{N+V} \times 100 (\%)$

- N** = Operation at power  $P_{max}$
- R** = Idle
- V** = Off-load operation
- f<sub>m</sub>** = Duty cycle



# Motor/Drive Associations

## Spindle Motors

### Association of AMS and IM Spindle Motors with NUM DrivePro



#### Association of AMS Motors with NUM DrivePro (Switching Frequency 5 kHz)

AMS...		Connection	MDLUF... 5 kHz	Continuous operation S1							Overload S6												
				Pn	$\omega_n$	$\omega_g$	$\omega_{lim}$	Pm	Cn	Icont	Pmax	Cmax	Ims	10 min									
				(kW)	(rpm)	(rpm)	(rpm)	(kW)	(Nm)	(Arms)	(kW)	(Nm)	(Arms)	(%)									
100	SB	Y	050A	3.7	1 500	6 500	6 500	3.7	24	20	6	40	35	22									
			050B												15 *								
	MB	Y	075A												5.5	10	80	53	13				
			075B																				
	GB	Y	100A												9	17	120	71	16				
	SD	Y	050A												3.7	12 000	1.8	24	20	6	40	35	22
			050B																				
	MD	Y	075A																				
075B																							
GD	Y	100A	9	17	120	71	16																
132	SA	Y	075A	5	750	6 000	7 000	2.8	64	26	10	150	53	16									
			075B																				
	SC	Y	100A	10	1 500	8	64	39	19	122	71	20											
	SE	$\Delta$	150A	15	1 750	4 000	10	82	52	29	160	106	13										
	MA	Y	100A	7.5	750	6 000	5.7	95	39	15	190	71	20										
	MC	Y	150A	15	1 500	12.5	52	30	190	106	16												
	ME	$\Delta$	200A	19.5	2 000	6 500	19	100	72	35	149	106	30										
	LA	Y	150A	11	750	6 000	9	140	52	23	292	106	16										
	LE	Y	200A	22	1 250	4 200	15	168	72	36	229	106	30										
	SF	Y	075A	5	750	6 000	10 000	2	64	26	10	150	53	16									
			075B																				
	SG	Y	100A	10	1 500	6	39	19	122	71	20												
	SH	$\Delta$	150A	15	1 750	4 000	7.5	82	52	29	160	106	13										
	MF	Y	100A	7.5	750	6 000	4	95	39	15	190	71	20										
	MG	Y	150A	15	1 500	9	52	30	190	106	16												
	MH	$\Delta$	200A	19.5	2 000	6 500	13.5	93	72	35	149	106	30										
	LF	Y	150A	11	750	6 000	9 000	7	140	52	23	292	106	16									
	LI	Y	100A	12.5	680	2 300	3	175	39	19	270	71	16										
	LH	Y	200A	22	1 250	4 200	12	168	72	36	229	106	30										
	160	MA	Y	150A	18	650	1 300	8 500	2.7	264	52	29	570	106	15								
$\Delta$																1 300	2 600	5.4	132	29	255	106	15
MB		Y	200A	26		1 200	2 400	7.3	208	72	36	290	106	35									
															$\Delta$	2 400	5 500	14.5	104	36	145	106	35
MC		$\Delta$	200A	36		1 700	2 800	11.8	202	100	47	265	141	10									
LA		Y	150A	18		500	1 000	6 500	2.8	344	52	27	740	106	15								
																$\Delta$	1 000	2 500	5.6	172	27	400	106
LB		Y	200A			26	950	1 900	7.6	260	72	36.4	364	106	35								
	$\Delta$				1 900											4 000	15.2	130	36.4	182	106	35	
LC	$\Delta$	200A	36		1 050	2 100	11.6	328	100	48	437	141	10										

\* Performance limited by drive type association (Bi-Axes drive)





#### Association of IM Motor with NUM DrivePro (Switching Frequency 5 kHz)

IM ...	Connection	MDLUF...	Continuous operation S1							Overload S6			
			Pn	wn	wg	wlim	Pm	Cn	Icont	Pmax	Cmax	Ims	10 min
			(kW)	(rpm)	(rpm)	(rpm)	(kW)	(Nm)	(Arms)	(kW)	(Nm)	(Arms)	(%)
18MK14	YY	400A	55	1 050	2 100	7 500	16.5	500	145	76	690	200	40



## Description

### NUM DrivePro

Like NUM FlexiumPro, the NUM DrivePro control unit has a very high integration level, thanks to its use of System on Chip technology incorporating a multi-core ARM processor. To avoid latency and overheads, there is no operating system between the CPUs and the software – it is a bare metal programming. As a result, the NUM DrivePro control unit can pilot up to 4 axes simultaneously, with a position loop sampling time of 50 µs.

A high degree of integration and efficiency has allowed us to achieve an extremely compact design that makes NUM DrivePro one of the smallest high-end drives on the market. Thanks to a small depth and a modular width (a multiple of 50 mm) the cabinet layout is greatly simplified.

The range is characterized by a wide choice of current from a few amperes up to 282 Arms, Bi-Axes versions are available up to 2 x 53 Arms and Quad-Axes versions up to 4 x 10 Arms, this allows to optimise each machine at the lowest cost and cabinet dimension. For the maximum contour precision, speeds and cost-effectiveness, the NUM DrivePro servo drives can be exactly adapted to the particular machine and application.

NUM DrivePro is a modular system that is optimized for multi-axes applications. Use of a common power supply unit means that only one mains connection, one line filter and one braking resistor are required per system, reducing cabling and overall costs. The system's modularity also facilitates energy exchange between different axes via the DC bus, offers the possibility of using stored energy for retraction purposes, and – in the case of regenerative power supplies – allows energy to be re-injected into the mains to reduce machine operating cost. Such system conception also leads the way for a greener approach.

NUM DrivePro offers a choice of two performance levels:

- Standard-Performance (SP) drives
- High-Performance (HP) drives

Featuring high internal resolution, a short sampling time and specially developed algorithms, the HP versions are designed for sophisticated and complex applications in precision machine tools. The position control loop is closed with a very high bandwidth, achieving exceptional precision and speed at the mechanical interface of the machine (motor axis, linear motor). NUM DrivePro accepts almost all measuring systems and can control a broad range of motors (servo, torque, linear, asynchronous motors) from NUM or other manufacturers. This ensures that a solution can be optimized from the technical and economic perspectives.

The HP versions of NUM DrivePro also incorporate unique functionality known as DEMF (Drive Embedded Macro). This allows users to create their own real-time macro which can interact with all physical and virtual drive resources – even to the extent of manipulating the regulation algorithms. Users can design and implement filters and monitors, define test points and create pilot outputs that obey user-stipulated rules.

The SP versions of NUM DrivePro are suited to systems and precision machine tools of medium complexity, as well as cost-sensitive applications.

Within the NUMSafe architecture, NUM DrivePro provides the safe motion functionalities by means of two different modules:

- NUM-STOX is the basic module for implementing the Safe Torque Off function certified up to SIL 3 according to IEC 61508. This allows the realization of E-STOP functions category 0 and 1 according to EN60204-1
- NUM-SAMX is the extended functionality module which provides a huge number of safe motion monitoring functions. STO Safe Torque Off, SLS Safely Limited Speed, SOS Safe Operational Stop, SS1 Safe Stop 1, SS2 Safe Stop 2, SLP Safe Limited Position, SDM Safe Direction Monitoring, SCA Safe CAMs and SSM Safe Speed Monitor

Every machine builder has experienced the complexity of encoder wiring and knows that it takes time and effort to install and debug satisfactorily. NUM DrivePro further improves the integration of the single cable motor; the fully digital encoder interface which uses a two-wires communication protocol has been further engineered by using a new industrial USB connector. For more detailed characteristics on such encoders please refer to the Motors chapter.

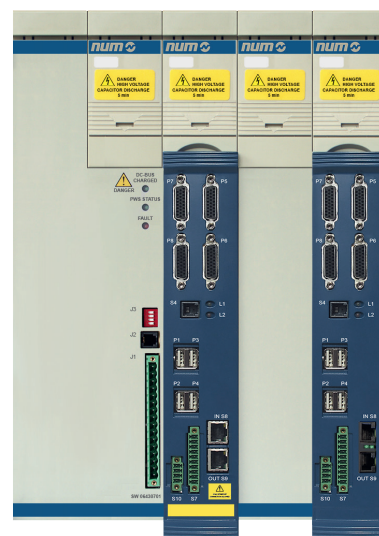

### System Overview

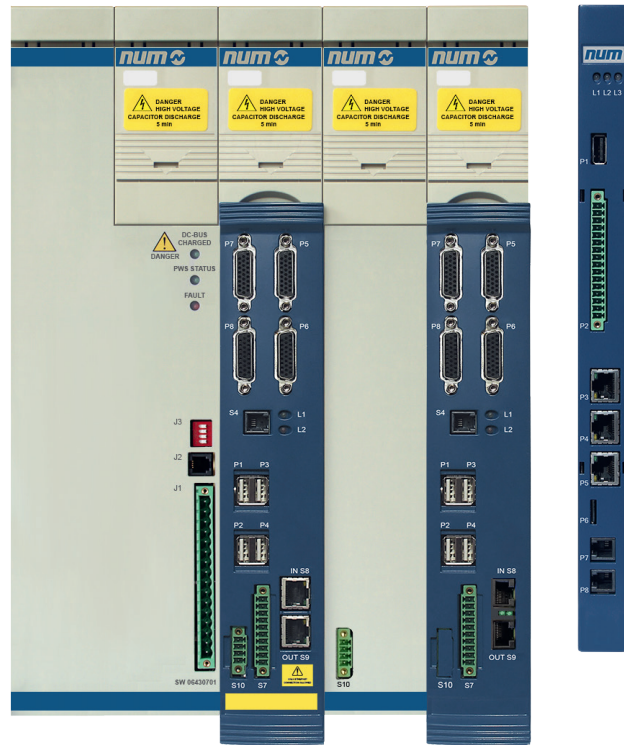

MDLL3  
Power supply  
module

MDLUF  
Bi-Axes  
with  
NUM-  
SAMX  
module

MDLUF Mono-Axis  
with NUM-STOX  
module

RTK  
FlexiumPro  
module

### MDLUF general description (i.e. High Performance Bi-Axes module with NUM-SAMX)

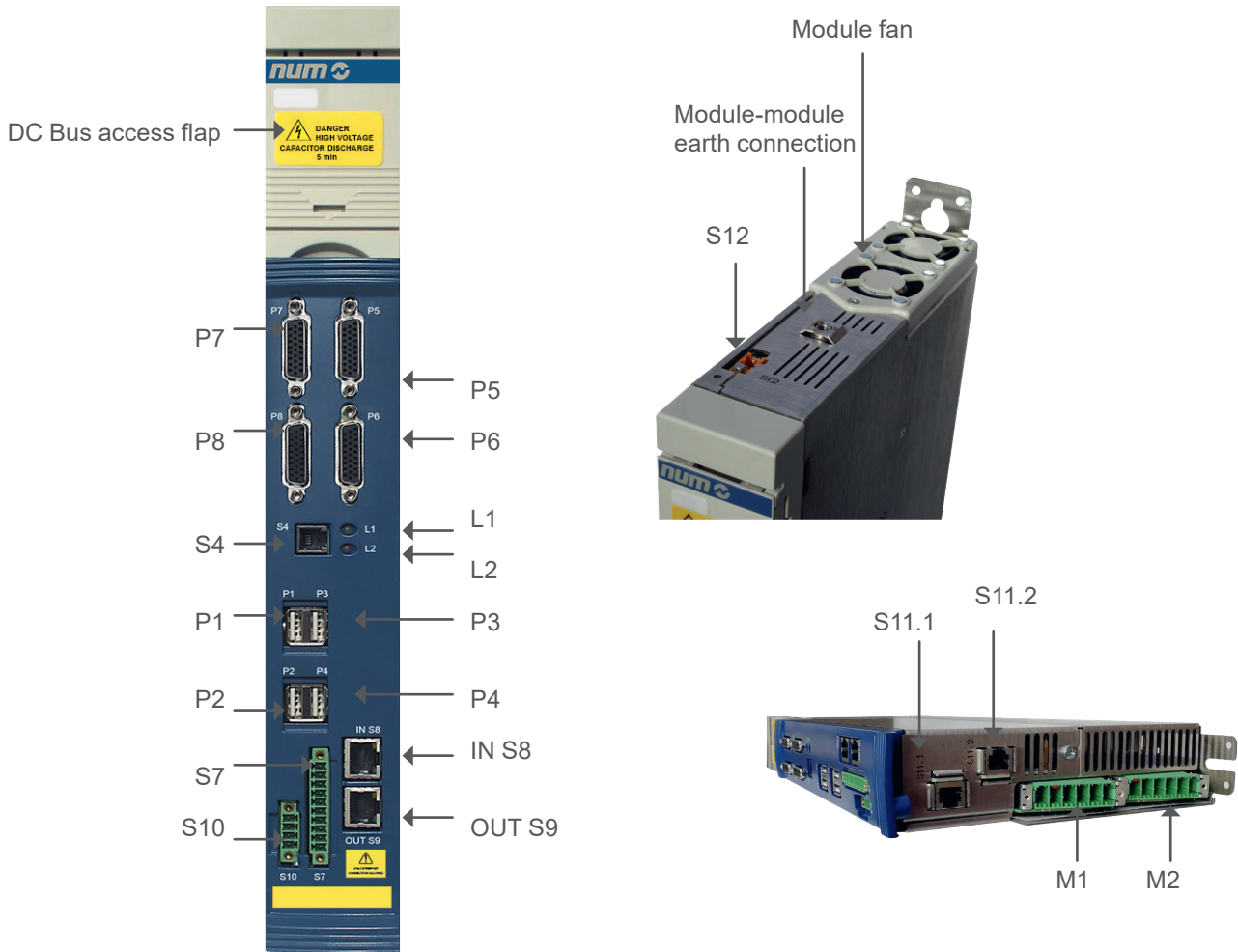

Connector	Description
L1, L2	L1 = EtherCAT status, L2 = EtherCAT error
P1, P2	Hiperface-DSL 2-wires sensor connections for Motor M1 / M2
P3, P4	Hiperface-DSL 2-wires sensor connections for Motor M3 / M4 for Quad-Axes drive
P5	Sub D HD 26 pins F - Motor sensor / Direct Axis measure sensor / VDR connections
P6	Sub D HD 26 pins F - Motor sensor / Direct Axis measure sensor / VDR connections
P7	Sub D HD 26 pins F - Motor sensor / Direct Axis measure sensor / VDR / Local Link connections
P8	Sub D HD 26 pins F - Motor sensor / Direct Axis measure sensor / VDR / Local Link connections
S4	NUM service
S7	10 screw pins +24VDC programmable IN/OUT
IN S8, OUT S9	RJ45 (8P/8C) Available with NUM-SAMX/NUM-STOX version only
S10	4 screw pins Motors brake control
S11.1, S11.2	RJ45 (8P/8C) Module - module digital bus interconnections
S12	2 screw pins AUX 48VAC input 35kHz Supply connections
M1, M2	6 screw pins for Motor M1 / M2 (power and brake)

### General Characteristics

<b>Power Supply AC/DC Converter</b> <ul style="list-style-type: none"> <li>• Input Voltage</li> <li>• Input Frequency</li> <li>• Rated Power</li> <li>• Dissipation of Braking Energy</li> </ul>	400 Vrms -10% to 480 Vrms +6% 3 phases or 230Vrms +/- 10% 1 phase 50/60Hz ± 5% from 5 kW up to 120 kW continuous power reinjection in mains or braking resistors
<b>Rated Output Current (DC/AC Converter)</b>	from 3.1 Arms up to 200 Arms continuous current
<b>Environment Storage Conditions</b> <ul style="list-style-type: none"> <li>• Temperature Range</li> <li>• Relative Humidity</li> </ul>	0 to + 70°C max. 75% without condensation
<b>Environment Working Conditions</b> <ul style="list-style-type: none"> <li>• Temperature Range</li> <li>• Relative Humidity</li> <li>• Vibration Stressing</li> <li>• Altitude</li> <li>• Pollution Degree</li> <li>• Electromagnetic Compatibility</li> </ul>	0 to 40°C without derating, max 60°C with derating max. 75% without condensation Complies with EN 61800-5-1 0 to 1000 m without derating, max 3000 m with derating 2, installation category II Conforms to EN 61800-3
<b>Functional Safety with NUM-SAMX</b> <ul style="list-style-type: none"> <li>• Safety Integrity Level (SIL)</li> <li>• PL</li> </ul>	up to 3 (EN61800-5-2) e (EN13849-1)
<b>Functional Safety with NUM-STOX</b> <ul style="list-style-type: none"> <li>• Safety Integrity Level (SIL)</li> <li>• PL</li> </ul>	up to 3 (EN61800-5-2) d (EN13849-1)



### Power Supply Technical Characteristics (MDLL)

MDLL power supplies are designed to be used in conjunction with NUM DrivePro. MDLLs supply the DC bus voltage and the control voltage (auxiliary voltage).

MDLLs are available in various power ratings and with dissipation of the braking energy by external resistor or with reinjection into the mains.

MDLQ is an auxiliary power supply used whenever the available built-in auxiliary power of the MDLL isn't sufficient (high number of drives). Refer to the installation manual for more information.

### Passive Power Supply

MDLL3 Power Supplies		MDLL3015N00AN0I	MDLL3030N00AN0I	MDLL3050N00AN0I	MDLL3120N00AN0I
Rated Power (S1)	kW	15	30	50	120
S3 Power (4s ON - 6s OFF)	kW	40	45	97	150
Peak Power	kW	50	50	97	175
Maximum Continuous Braking Power	kW	15	30	20	20
Peak Braking Power	kW	51	61	120	170
Rated Input Voltage	V	400 Vrms -10% to 480 Vrms +6% 50/60Hz ± 5% 3 phases			
Rated Input Current	Arms	31	62	100	194
DC Bus Voltage at Rated Power	VDC	540 VDC with 400 Vrms input, 650 VDC with 480 Vrms input			
Dissipation of Braking Energy		On external braking resistor			
Auxiliary Rated Power	W	230		180	200
Protection Degree (EN60529)		IP20		IP00	
Overall Dimensions (WxHxD)	mm	100 x 355 x 206		200 x 355 x 206	300 x 355 x 206
Weight	kg	5.5		11.5	19

### Regenerative Power Supply

MDLL3 Power Supplies		MDLL3025N00RN0I	MDLL3050N00RN0I	MDLL3120N00RN0I
Rated Power (S1)	kW	25	50	120
S3 Power (4s ON - 6s OFF)	kW	50	97	150
Peak Power	kW	50	97	175
Maximum Continuous Braking Power	kW	25	50	120
Peak Braking Power	kW	61	120	170
Rated Input Voltage	V	400 Vrms -10% to 480 Vrms +6% 50/60Hz ± 5% 3 phases		
Rated Input Current	Arms	50	100	194
DC Bus Voltage at Rated Power	VDC	540 VDC with 400 Vrms input, 650 VDC with 480 Vrms input		
Dissipation of Braking Energy		Reinjection in mains		
Auxiliary Rated Power	W	180		200
Protection Degree (EN60529)		IP00		
Overall Dimensions (WxHxD)	mm	200 x 355 x 206		300 x 355 x 206
Weight	kg	11.5		19



### Regenerative Power Supply with controlled DC Bus Voltage

MDLL3 Power Supplies		MDLL3025N00HN0I	MDLL3050N00HN0I	MDLL3120N00HN0I
Rated Power (S1)	kW	25	50	120
S3 Power (4s ON - 6s OFF)	kW	50	97	150
Peak Power	kW	50	97	190
Maximum Continuous Braking Power	kW	25	50	120
Peak Braking Power	kW	61	120	200
Rated Input Voltage	V	400 Vrms -10% to 480 Vrms +6% 50/60Hz ± 5% 3 phases		
Rated Input Current	Arms	36	72	173
DC Bus Voltage at Rated Power	VDC	Configurable DC Bus voltage: 600, 650, 700 VDC		
Dissipation of Braking Energy		Reinjection in mains		
Auxiliary Rated Power	W	180		200
Protection Degree (EN60529)		IP00		
Overall Dimensions (WxHxD)	mm	200 x 355 x 206		300 x 355 x 206
Weight	kg	11.5		19

### Passive Power Supply single phase 230 Vrms

MDLL3 Power Supplies		MDLL3005M00AN0I
Rated Power (S1)	kW	5
S3 Power (4s ON - 6s OFF)	kW	6
Peak Power	kW	6
Maximum Continuous Braking Power	kW	5
Peak Braking Power	kW	9
Rated Input Voltage	V	230Vrms -10% + 230Vrms +10% (Single-phase)
Rated Input Current	Arms	31
DC Bus Voltage at Rated Power	VDC	300 VDC with 230Vrms input
Dissipation of Braking Energy		On braking resistor
Auxiliary Rated Power	W	200
Protection Degree (EN60529)		IP20
Overall Dimensions (WxHxD)	mm	100 x 355 x 206
Weight	kg	5.5

### Auxiliary Power Supply for Control Voltage

MDLQ3 Power Supply		MDLQ3001N00
Auxiliary Rated Power	W	250
Input Voltage	V	400 Vrms -10% to 480 Vrms +6% 50/60Hz ± 5% 2 phases
Protection Degree (EN60529)		IP20
Overall Dimensions (WxHxD)	mm	50 x 355 x 206
Weight	kg	2.8

The MDLQ auxiliary power supply is only required if the MDLL's auxiliary output has insufficient power to meet the control voltage supply needs of the complete drive line-up.

### Servo Drive Interoperability and Functions (MDLUF)

		Bi-Axes and Quad-Axes SP (Standard Performance)	Mono-Axis, Bi-Axes and Quad-Axes HP (High Performance)
Interface	EtherCAT with NUM device profile	•	•
Control Performance	Standard performance control loops	•	•
	High performance control loops	-	•
Compatible Motors	Closed loop: synchronous rotary motors <sup>1</sup>	• <sup>2</sup>	•
	Closed loop: synchronous torque and linear motors	-	•
	Closed loop: asynchronous motors	•	•
	Open loop: synchronous or asynchronous rotary motors (V/F mode)	•	•
Compatible Motor Sensor	Single cable motor encoder (SHX, SPX motors)	•	•
	EnDat 2.1 & EnDat 2.2 encoder	•	•
	1 Vpp toothed wheel / encoder	•	•
	Renishaw RESOLUTE™ encoders with BiSS unidirectional interface	•	•
	Magnescale encoders	•	•
Compatible Direct Measure Sensors	EnDat 2.1 & EnDat 2.2 encoder / linear scale	-	•
	Hall sensors	-	•
	1 Vpp encoder / linear scale (also with coded references)	-	•
	Renishaw RESOLUTE™ encoder with BiSS unidirectional interface	-	•
	Magnescale encoders	-	•
Special Functions	Spindle operation for synchronous and asynchronous motors	•	•
	Synchronous motor phasing without movement <sup>3</sup>	•	•
	Spindle-Axis commutation	•	•
	Rotary axis with mechanical ratio not 2 <sup>n</sup> (AP02)	•	•
	Anti-backlash function (AP03) <sup>4,5</sup>	-	○
	Torque duplication (AP04) <sup>5,6</sup>	-	○
	Winding duplication (AP05) <sup>5,6</sup>	-	○
	DEMF (Drive Embedded Macro / AP07) <sup>7</sup>	-	○
	Coherence control between motor and direct measure sensor (AP06)	-	•
	Various active damping functions	-	•
Various freely settable filters (AP11, AP12)	•	•	
Electrical Position Synchronization (EPS)	•	•	
Absolute position with motor's multi-turn encoder and incremental direct measure sensor	-	•	

<sup>1</sup> Having a compatible position sensor

<sup>2</sup> For standard performance, max. 8 pole pairs motors

<sup>3</sup> Required with incremental encoders

<sup>4</sup> Not allowed for asynchronous motors in V/F mode

<sup>5</sup> On Mono-axis drive, available with dedicated version MDLUF---AED---

<sup>6</sup> Not allowed for asynchronous motors

<sup>7</sup> Subject to international export control

• Standard      ○ Optional      - Not Available

### Servo Drive Interoperability and Functions (MDLUF)

		Bi-Axes and Quad-Axes SP (Standard Performance)	Mono-Axis, Bi-Axes and Quad-Axes HP (High Performance)
Safety Functions compliant with EN 61800-5-2	NUM-STO module with Safe Torque Off <sup>8</sup>	○	○ <sup>9</sup>
	NUM-SAMX module with <ul style="list-style-type: none"> <li>• STO Safe Torque Off</li> <li>• SLS Safely Limited Speed</li> <li>• SOS Safe Operational Stop</li> <li>• SS1 Safe Stop 1</li> <li>• SS2 Safe Stop 2</li> <li>• SLP Safe Limited Position</li> <li>• SDM Safe Direction Monitoring</li> <li>• SCA Safe CAMs</li> <li>• SSM Safe Speed Monitor</li> </ul>	○	○ <sup>9</sup>

<sup>8</sup> Not Available on Quad-Axes drive







<sup>9</sup> Not available on MDLUF200

● Standard      ○ Optional      - Not Available

### Servo Drive Technical Characteristics (MDLUF)

MDLUF servo drive modules must always be selected to suit the associated motor. They are available in 16 ratings as shown below.

All MDLUF modules have the same depth and height, and their width varies in standard modular increments (multiples of 50mm), allowing easy mounting in electrical cabinets. A built-in brake management scheme eliminates the need for an external control relay.

MDLUF Module Size	Type	Reference	Rated Current	Maximum Current
Size 1, 50mm 	Mono-Axis	MDLUF007AExxN0I MDLUF014AExxN0I MDLUF021AExxN0I MDLUF034AExxN0I	4.4 Arms 8.9 Arms 13 Arms 14 Arms	5 Arms 10 Arms 15 Arms 24 Arms
	Bi-Axes	MDLUF007BExxN0I MDLUF014BExxN0I MDLUF021BExxN0I	3.1 + 3.1 Arms 6.3 + 6.3 Arms 7 + 7 Arms	5 + 5 Arms 10 + 10 Arms 15 + 15 Arms
Size 2, 100mm 	Mono-Axis	MDLUF050AExxN0I MDLUF075AExxN0I	28 Arms 34 Arms	35 Arms 53 Arms
	Bi-Axes	MDLUF050BExxN0I	20 + 20 Arms	35 + 35 Arms
Size 2, 100mm 	Quad-Axes	MDLUF014DExxN0I	6.3 + 6.3 + 6.3 + 6.3 Arms	10 + 10 + 10 + 10 Arms
Size 3, 150mm 	Mono-Axis	MDLUF100AExxN0I MDLUF150AExxN0I	45 Arms 60 Arms	71 Arms 106 Arms
	Bi-Axes	MDLUF075BExxN0I	29 + 29 Arms	53 + 53 Arms
Size 4, 200mm 	Mono-Axis	MDLUF200AExxN0I	100 Arms	141 Arms
Size 6, 300mm 	Mono-Axis	MDLUF400AExxN0I	200 Arms	282 Arms

### Mono-Axis Drive up to 50A

Mono-Axis		MDLUF007A...		MDLUF014A...		MDLUF021A...		MDLUF034A...		MDLUF050A...	
Switching Frequency	kHz	5	10	5	10	5	10	5	10	5	10
Rated Current (S1)	Arms	4.4	4.4	8.9	6	13	8	14	8	28	18
Maximum Current	Arms	5		10		15		24		35	
Auxiliary Power Consumption <sup>1</sup>	W	18.5								22.5	
Protection Degree (EN60529)		IP20									
Overall Dimensions (WxHxD)	mm	50x355x206								100x355x206	
Weight	kg	3.7								7	

### Mono-Axis Drive up to 400A

Mono-Axis		MDLUF075A...		MDLUF100A...		MDLUF150A...		MDLUF200A...		MDLUF400A...	
Switching Frequency	kHz	5	10	5	10	5	10	5	10	5	10
Rated Current (S1)	Arms	34	23	45	34	60	40	100	70	200	130
Maximum Current	Arms	53		71		106		141		282	
Auxiliary Power Consumption <sup>1</sup>	W	22.5		32		32		42.5		27.5	
Protection Degree (EN60529)		IP20		IP00							
Overall Dimensions (WxHxD)	mm	100 x 355 x 206		150 x 355 x 206				200 x 355 x 206		300 x 355 x 206	
Weight	kg	7		8.5				12		18	

### Bi-Axes Drive

Bi-Axes		MDLUF007B...		MDLUF014B...		MDLUF021B...		MDLUF050B...		MDLUF075B...	
Switching Frequency	kHz	5	10	5	10	5	10	5	10	5	10
Rated Current (S1)	Arms	3.1+3.1	3.1+3.1	6.3+6.3	4.2+4.2	7+7	4.7+4.7	20+20	13+13	29+29	20+20
Maximum Current	Arms	5+5		10+10		15+15		35 + 35		53+53	
Auxiliary Power Consumption <sup>1</sup>	W	21.5				28.5				35	
Protection Degree (EN60529)		IP20									
Overall Dimensions (WxHxD)	mm	50 x 355 x 206						100 x 355 x 206		150 x 355 x 206	
Weight	kg	3.7						7.2		8.8	

<sup>1</sup> Without considering sensor power supply. Add 1W for each connected sensor (motor or direct).

Refer to installation manual for more information and dimensioning rules.

### Quad-Axes Drive

Quad-Axis		MDLUF014D...	
Switching Frequency	kHz	5	10
Rated Current (S1)	Arms	6.3+6.3+6.3+6.3	4.2+4.2+4.2+4.2
Maximum Current	Arms	10+10+10+10	
Auxiliary Power Consumption <sup>1</sup>	W	33	
Protection Degree (EN60529)		IP20	
Overall Dimensions (WxHxD)	mm	100 x 355 x 206	
Weight	kg	5.9	

<sup>1</sup> Without considering sensor power supply. Add 1W for each connected sensor (motor or direct).

Refer to installation manual for more information and dimensioning rules.

## MDLUF Outlines (Size 1)

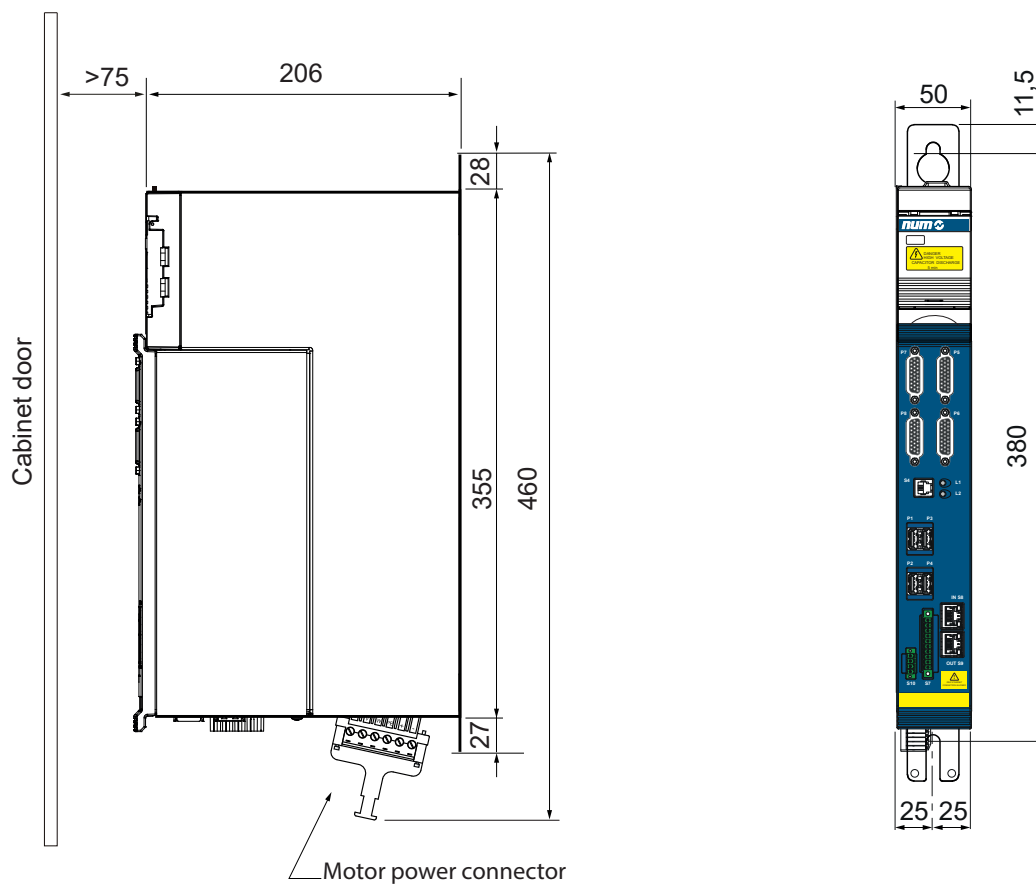

Module Description	Code
Mono-Axis	MDLUF007AExxN0I
	MDLUF014AExxN0I
	MDLUF021AExxN0I
	MDLUF034AExxN0I
Bi-Axes	MDLUF007BExxN0I
	MDLUF014BExxN0I
	MDLUF021BExxN0I

## MDLUF Outlines (Size 2)

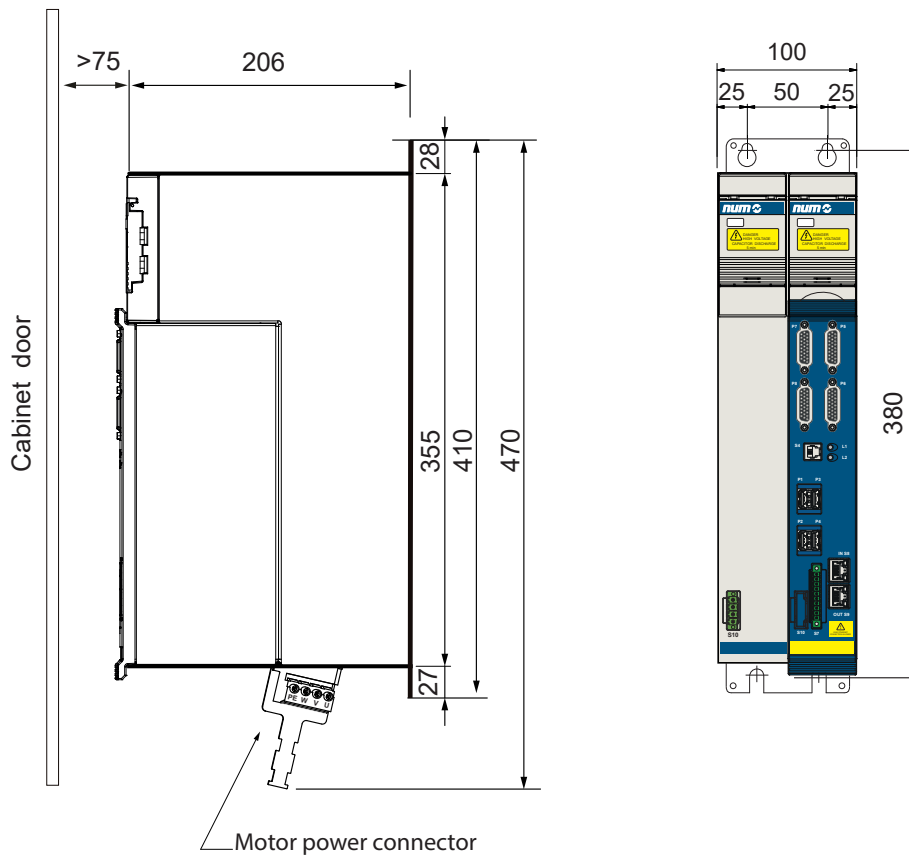

Module Description	Code
Mono-Axis	MDLUF050AExxN0I MDLUF075AExxN0I
Bi-Axes	MDLUF050BExxN0I



# NUM DrivePro

Servo Drive

Outlines Size 2 Quad - Axes

## MDLUF Outlines (Size 2)

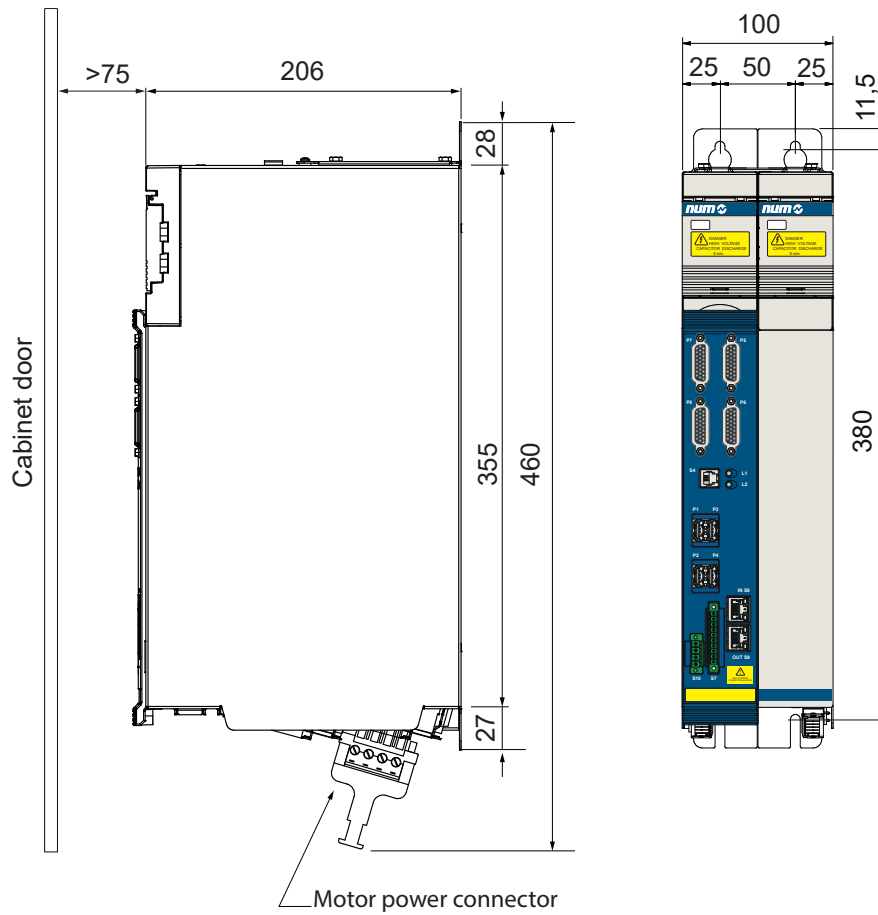

8

Module Description	Code
Quad-Axes	MDLUF014DExxN01

## MDLUF Outlines (Size 3)

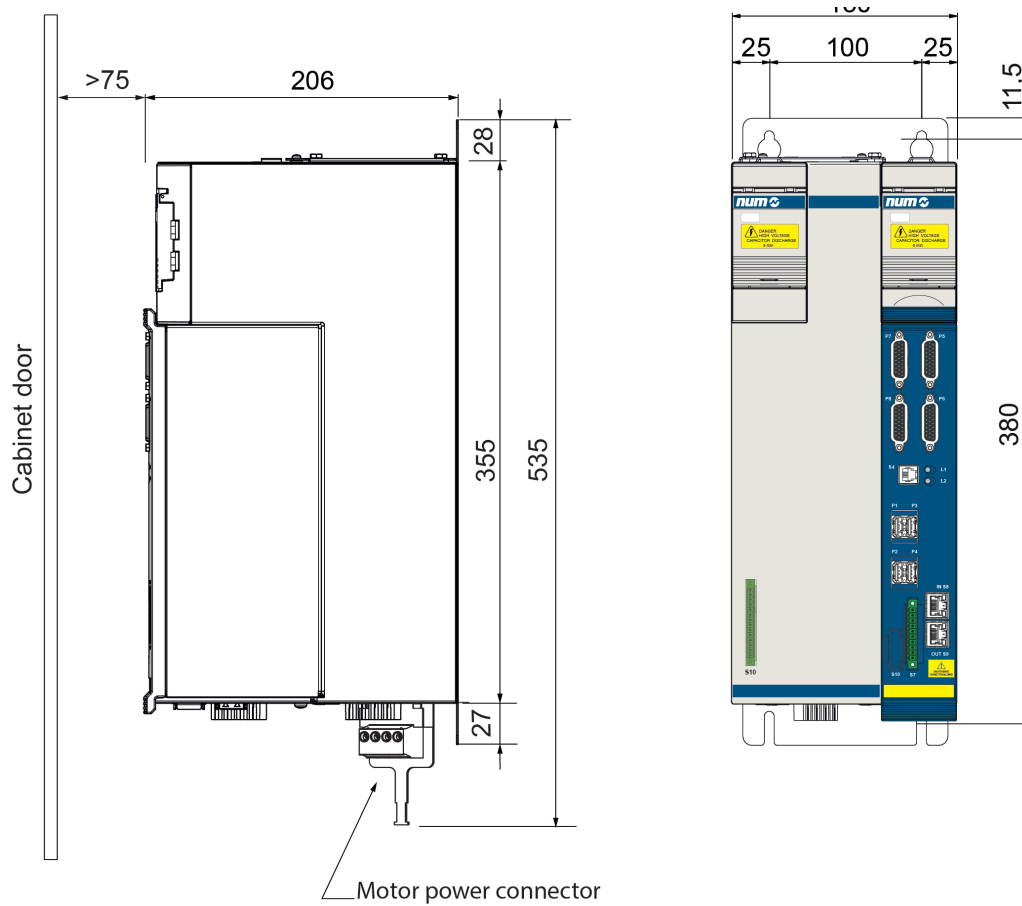

Module Description	Code
Mono-Axis	MDLUF100AExxN01 MDLUF150AExxN01
Bi-Axes	MDLUF075BExxN01

## MDLUF Outlines (Size 4)

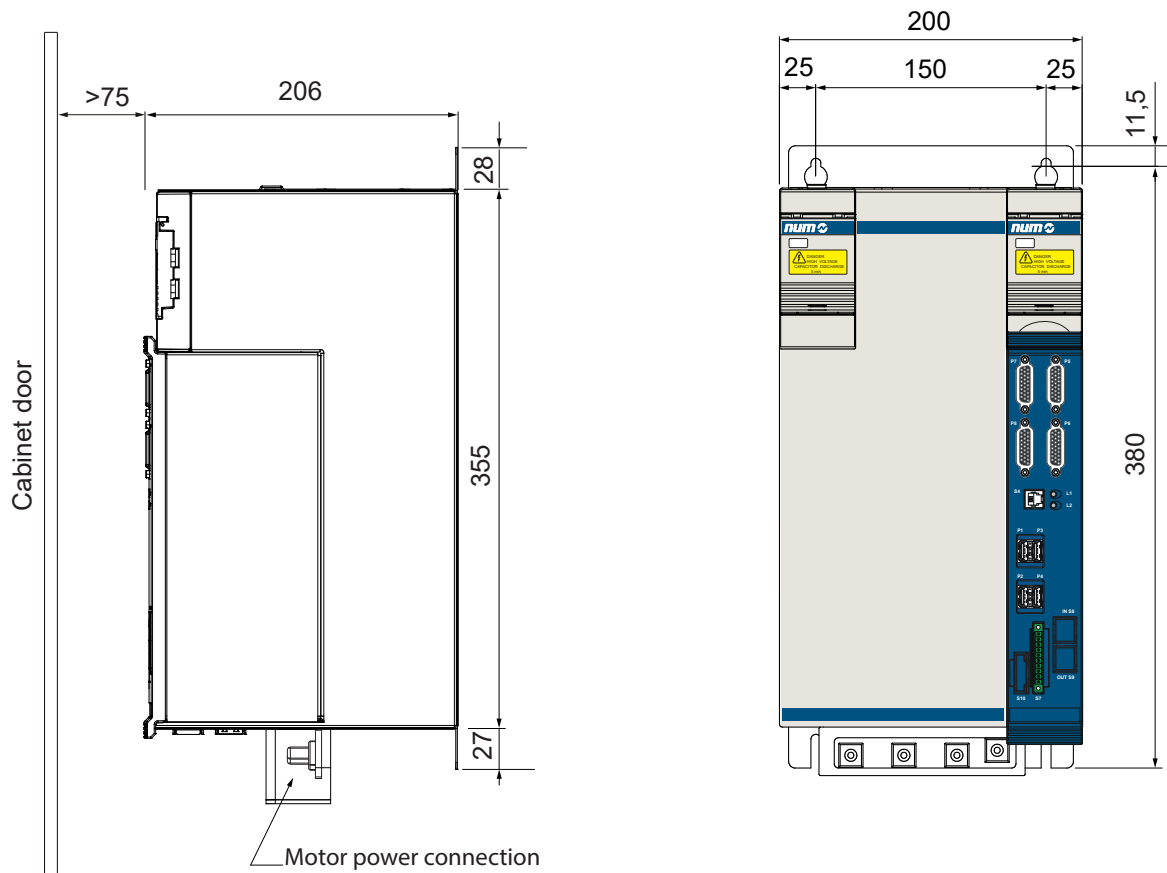

Module Description	Code
Mono-Axis	MDLUF200AExxN01

## MDLUF Outlines (Size 6)

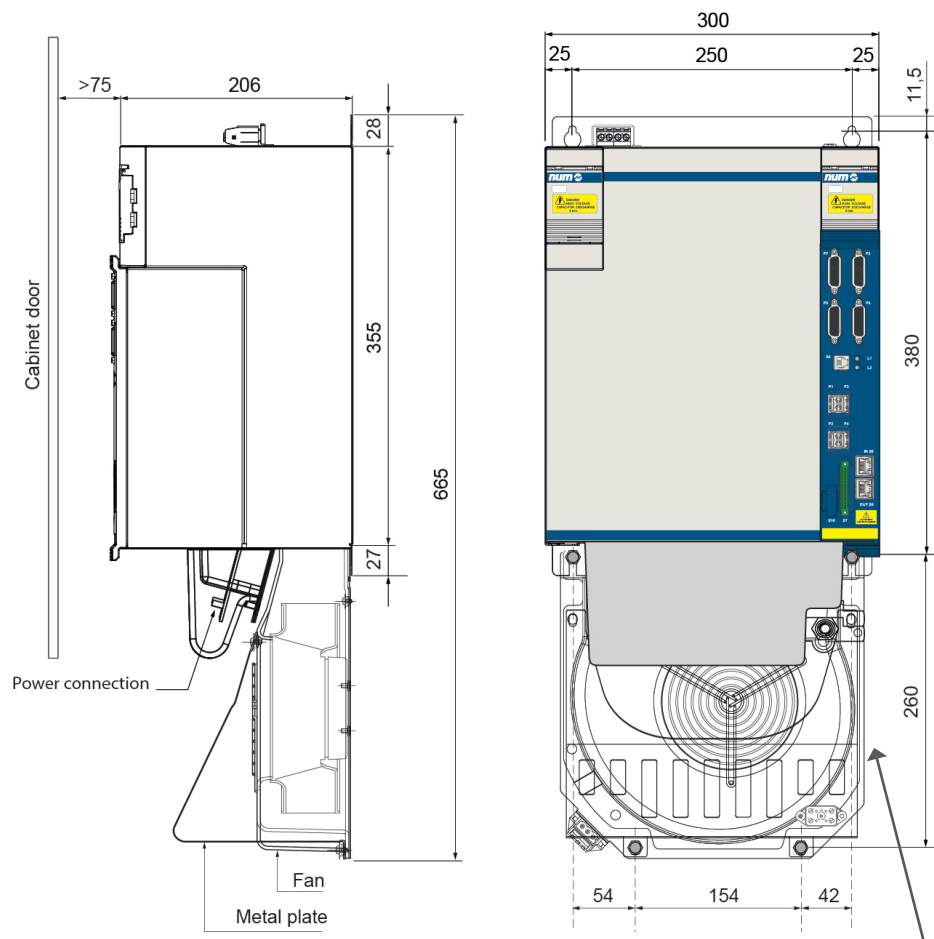

AGOFAN001 not included.  
To be ordered separately.

Module Description	Code
Mono-Axis	MDLUF400AExxN01

## MDLL3 Outlines (Size 2)

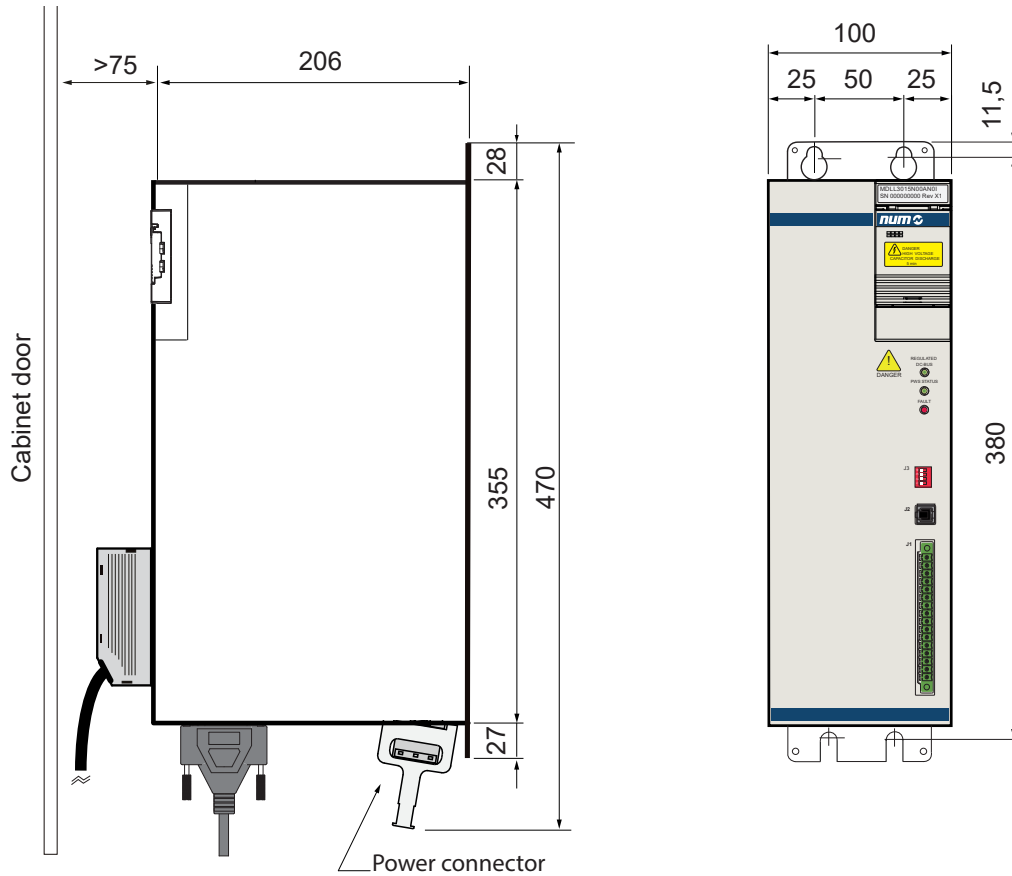

Module Description	Code
Power supply Module 100mm	MDLL3015N00AN0I MDLL3030N00AN0I MDLL3005M00AN0I

## MDLL3 Outlines (Size 4)

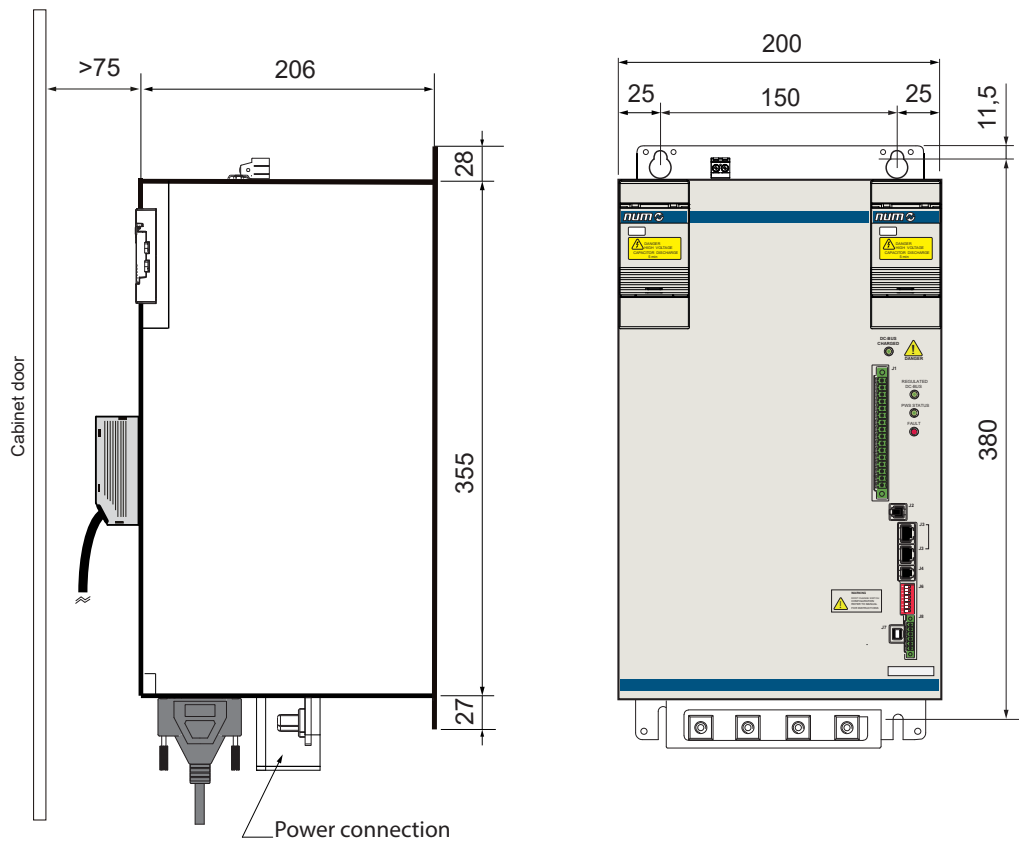

Module Description	Code
Power supply Module 200mm	MDLL3050N00AN0I
	MDLL3025N00RN0I
	MDLL3050N00RN0I
	MDLL3025N00HN0I
	MDLL3050N00HN0I

## MDLL3 Outlines (Size 6)

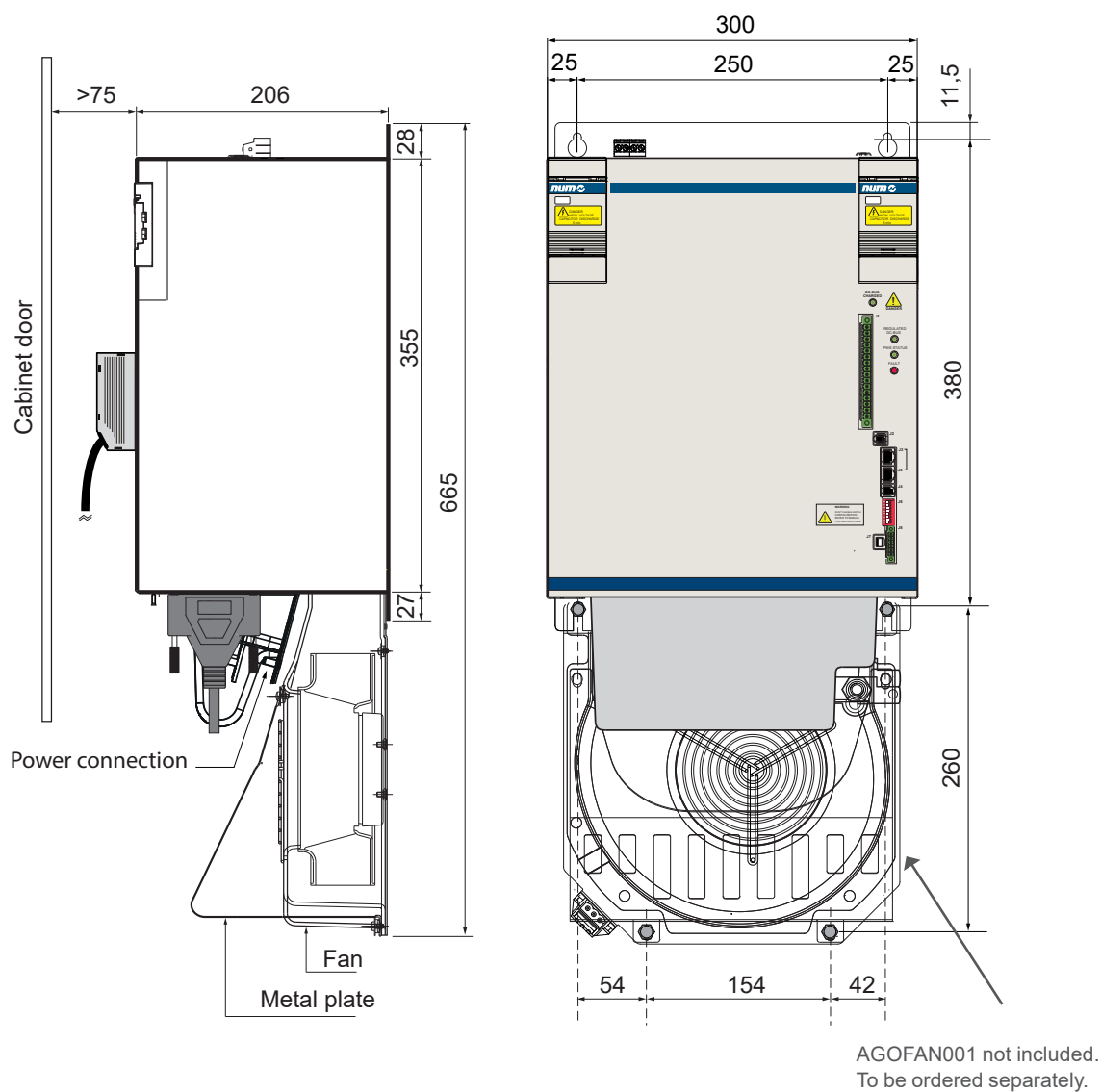

Module Description	Code
Power supply Module 300mm	MDLL3120N00AN01 MDLL3120N00RN01 MDLL3120N00HN01

## MDLQ3 Outlines (Size 1)

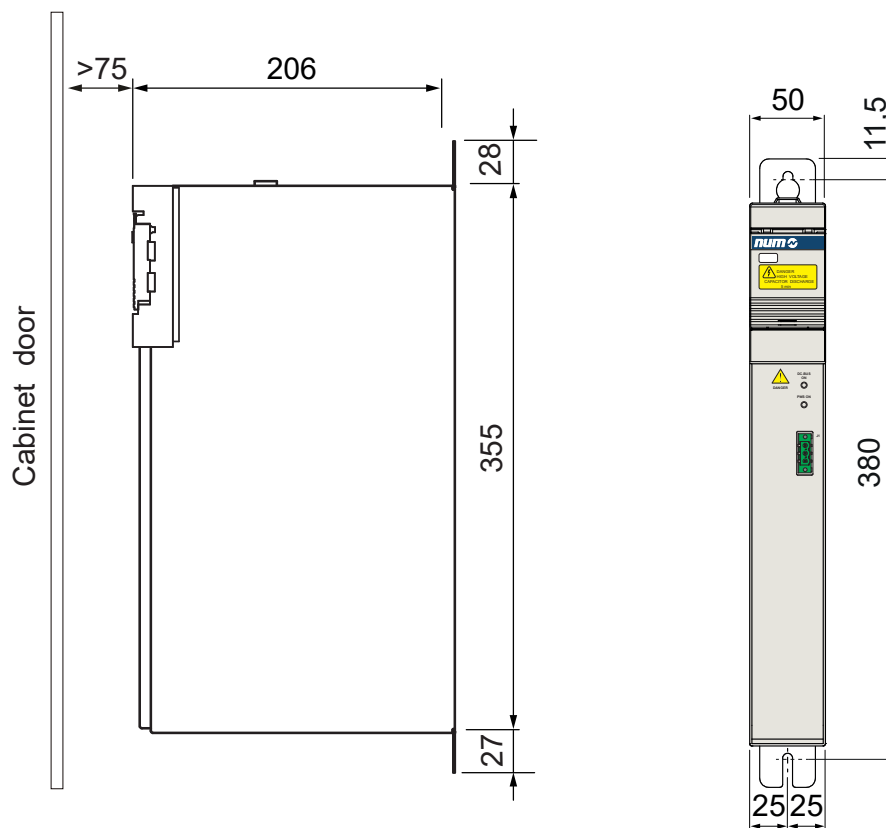

Module Description	Code
Additional 250W AUX Module	MDLQ3001N00



### Power Supply

	MDLL	3	015	N	00	A	N	0	I
<b>Series</b>									
<b>Evolution Index</b>									
<b>Rated Power</b>									
• Size 2: Pn 5kW			005						
• Size 2: Pn 15kW			015						
• Size 2: Pn 30kW			030						
• Size 4: Pn 25kW			025						
• Size 4: Pn 50kW			050						
• Size 6: Pn 120kW <sup>6</sup>			120						
<b>Mains Supply</b>									
• From 230Vac -10% to 230Vac +6% 50/60Hz +/-5%, Single phase				M <sup>1</sup>					
• From 400Vac -10% to 480Vac +6% 50/60Hz +/-5%, 3 phases				N <sup>2</sup>					
<b>Options</b>									
• None					00				
<b>Type</b>									
• Passive power supply <sup>3,4</sup>						A			
• Regenerative power supply <sup>3,5</sup>						R			
• Regulated DCBus power supply <sup>3,5</sup>						H			
<b>Version</b>									
• Standard NUM							N		
<b>Standard NUM</b>								0	
<b>Heat-Sink Position</b>									
• Internal heat-sink									I

<sup>1</sup> Available only on Pn 5kW rated power  
<sup>2</sup> Not available on Pn 5kW rated power  
<sup>3</sup> An external braking resistor must be always used  
<sup>4</sup> Not available on Pn 25kW  
<sup>5</sup> Not available on Pn 5kW, Pn 15kW and Pn 30kW rated power  
<sup>6</sup> An external fan AGOFAN001 + AEOKIT003 must be always taken in account

### Servo Drive

	MDLUF	014	A	E	C	F	N	0	I
<b>Series</b>									
<b>Flated Power</b>									
<b>Mono-Axis</b>									
• Size 1: In 4.4Arms, lpeak 5Arms		007							
• Size 1: In 8.9Arms, lpeak 10Arms		014							
• Size 1: In 13Arms, lpeak 15Arms		021							
• Size 1: In 13Arms, lpeak 24Arms		034							
• Size 2: In 28Arms, lpeak 35Arms		050							
• Size 2: In 34Arms, lpeak 53Arms		075							
• Size 3: In 45Arms, lpeak 71Arms		100							
• Size 3: In 60Arms, lpeak 106Arms		150							
• Size 4: In 100Arms, lpeak 141Arms <sup>7</sup>		200							
• Size 6: In 200Arms, lpeak 282Arms <sup>1</sup>		400							
<b>Bi-Axes</b>									
• Size 1: In 3.1+3.1Arms, lpeak 5+5Arms		007							
• Size 1: In 6.3+6.3Arms, lpeak 10+10Arms		014							
• Size 1: In 6.3+6.3Arms, lpeak 15+15Arms		021							
• Size 2: In 20+20Arms, lpeak 35+35Arms		050							
• Size 3: In 29+29Arms, lpeak 53+53Arms		075							
<b>Quad-Axes</b>									
• Size 2: In 6.6+6.3+6.3+6.3 Arms, lpeak 10+10+10+10 Arms		014							
<b>Axis Number</b>									
• Mono-Axis			A						
• Bi-Axes			B						
• Quad-Axes			D						
<b>Communication</b>									
• DISC ET <sup>2</sup>				E					
<b>Version</b>									
• Standard Performance <sup>3</sup>					A				
• High Performance					C				
• High Performance with external link <sup>4</sup>					D				
<b>Safety</b>									
• Without Safety module						A			
• Certified NUM-STOX (Safe Torque Off) module according to EN61800-5-2 up to SIL 3 <sup>5</sup> (only for Mono and Bi-Axes)						E			
• Certified NUM-SAMX G2 Safety module according to EN61800-5-2 up to SIL 3 <sup>6</sup>						F			
<b>Standard NUM</b>							N		
<b>Fixed Value</b>								0	
<b>Heat-Sink Position</b>									I
• Internal heat-sink									I

<sup>1</sup> An external fan AGOFAN001 and AEOKIT006 must be always taken in account

<sup>2</sup> DISC ET bus RJ45-RJ45 cable connection AEOFRU018Mxxxx must be always taken in account for each drive. One AEOFRU016Mxxxx DB25-RJ45 cable must be always taken in account for the first drive located on the right of the power supply. One AEOFRU017Mxxxx RJ45-RJ45 cable must be always taken in account for the last drive to be connected with the RTK module

<sup>3</sup> Not available for Mono-Axis version

<sup>4</sup> Not available for Bi-Axes and Quad-Axes version, required for Mono-Axis tandem function

<sup>5</sup> Not available for Quad-Axes version and MDLUF200

<sup>6</sup> No motor sensor on P7 or P8 allowed and not available for MDLUF200

<sup>7</sup> Not available with NUM-STOX or NUM-SAMX G2



### General Characteristics

NUM's EtherCAT Terminal is a modular system available with different configurable devices:

- Gateway modules CTMG1100
- Extension modules CTMG1110
- Digital and Analogue I/O modules CTMTxxxx
- Safe PLC modules CTMP6900 and CTMP1960-2600 <sup>1</sup>
- Safe I/O modules CTMS1904, CTMS2904 and CTMS2912
- Technology modules CTMTxxxx

Machine builders can easily create their own configurations from a mix of different devices. Each line-up requires a gateway to receive messages from the EtherCAT field bus and propagate them to the different devices via the internal E-bus. Please also refer to chapter 2 for further information on NUM's EtherCAT process and terminal combinations.

### NUM EtherCAT Terminals Mixed Combination

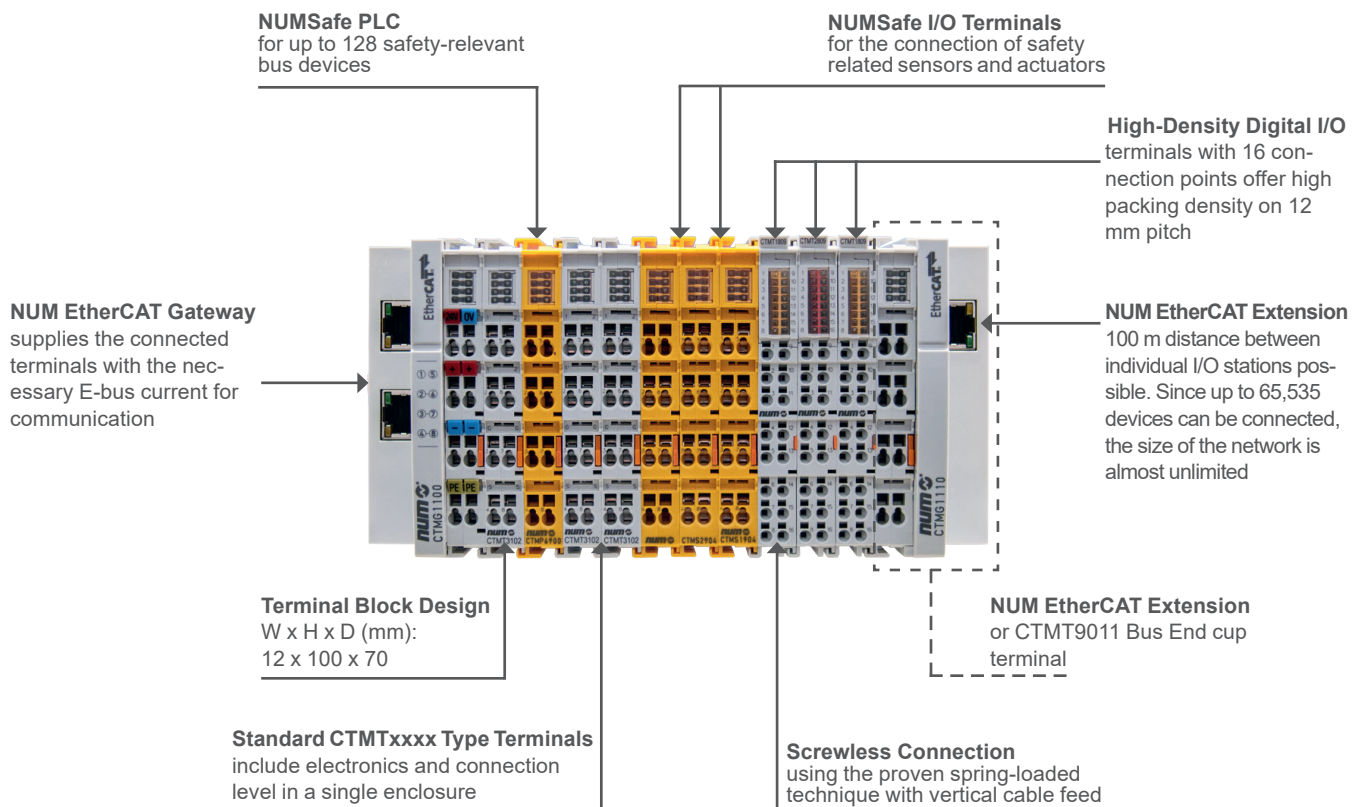

<sup>1</sup> For more detailed information on the Safe PLC and Safe I/O modules please refer to the M00033, M00034, M00035, M00037, M00038, M00060 and M00061 manuals.



### Structure

---

Robust housings, secure contacts and solidly built electronics are prominent features of NUM components. An I/O station consists of an EtherCAT Gateway and almost any number of terminals. Since up to 65,535 devices can be connected, the size of the network is almost unlimited. The electronic terminal blocks are attached to the EtherCAT Gateway. The contacts are made as the terminal clicks into place, without any other manipulation.

This means that each electronic terminal block can be individually exchanged. It can be placed on a standard DIN rail.

A clearly arranged connection panel with LEDs for status display and push-in contact labels ensures clarity in the field. 3-wire conductors with an additional connection for a protective conductor, enable direct connection of sensors and actuators.

### Free Mix of Signals

---

Suitable EtherCAT Terminals are available for all common digital and analog signal types encountered in the world of automation. NUM EtherCAT Terminals enable bit-precise composition of the required I/O channels.

The digital EtherCAT Terminals are designed as 2-, 4-, 8- or 16-channel terminals.

In the 16-channel variant, digital input and output signals are arranged in an ultra-compact way within a standard terminal housing across a width of only 12mm. The standard analog signals of  $\pm 10$  V, 0...10 V, 0...20mA and 4...20mA are all available as 1-, 2-, 4- and 8-channel variants within a standard housing.



## Gateways and Terminals

Description	Commercial Reference	Task / Connection Technology	E-bus Power Consumption [mA]
<b>Gateway</b>			
EtherCAT gateway	<b>CTMG1100</b>	Connects EtherCAT with terminal	70
EtherCAT extension	<b>CTMG1110</b>	Extends EtherCAT connection	130
<b>Digital Input</b>			
4-channel digital input terminal 24 VDC, 3 ms	<b>CTMT1004</b>	2-wire connection	90
8-channel digital input terminal 24 VDC, 3 ms	<b>CTMT1008</b>	1-wire connection	90
HD EtherCAT Terminal, 4-channel digital input 24 VDC	<b>CTMT1804</b>	3-wire connection	100
HD EtherCAT Terminal, 16-channel digital input 24 VDC	<b>CTMT1809</b>	1-wire connection	100
<b>Digital Inputs and Outputs</b>			
EtherCAT Terminal, 8 digital Input- and Output channels	<b>CTMT1859</b>	1-wire connection	130
<b>Digital Output</b>			
4-channel digital output terminal 24 VDC, 0.5 A	<b>CTMT2004</b>	2-wire connection	100
8-channel digital output terminal 24 VDC, 0.5 A	<b>CTMT2008</b>	1-wire connection	110
4-channel digital output terminal 24 VDC, 2A	<b>CTMT2024</b>	2-wire connection	110
2-channel relay output terminal 230 VAC, 2A	<b>CTMT2602</b>	Relay output 1-wire connection	170
2-channel relay output terminal, 125 VAC, 1A	<b>CTMT2612</b>	Relay output	150
HD EtherCAT Terminal, 16-channel digital output 24 VDC, 0.5 A	<b>CTMT2809</b>	1-wire connection	140
<b>Analog Input</b>			
2-channel analog input terminal -10...+10 V, differential input, 16 bits	<b>CTMT3102</b>	2 (differential) Inputs	180
2-channel analog input terminal 4...20 mA, differential input, 16 bits	<b>CTMT3122</b>	2 (differential) Inputs	180
2-channel analog input terminal 0...10 V, single-ended, 16 bits	<b>CTMT3162</b>	2 (single-ended) Inputs	180
2-channel input terminal PT100 (RTD) for 2- or 3-wire connection	<b>CTMT3202</b>	2 Inputs, 2-/3 wire (default 3-wire) connection	190
<b>Analog Output</b>			
2-channel analog output terminal 0...10 V, 16 bits	<b>CTMT4102</b>	2 (single ended) Outputs, 2-wire	210
2-channel analog output terminal 4...20 mA, 16 bits	<b>CTMT4122</b>	2 (single ended) Outputs, 2-wire	190
2-channel analog output terminal -10...+10 V, 16 bits	<b>CTMT4132</b>	2 (single ended) Outputs, 2-wire	210
<b>Communication</b>			
Serial interface 1 x RS232	<b>CTMT6001</b>		120
Serial interface 1 x RS422/RS485	<b>CTMT6021</b>		220
EtherCAT IO-Link Master <sup>1</sup>	<b>CTMT6224</b>		500
<b>System Terminals</b>			
End cap	<b>CTMT9011</b>		0
Potential supply, 24 VDC	<b>CTMT9100</b>		0
Potential supply, 24 VDC, with diagnostics	<b>CTMT9110</b>		90
Power supply terminals for E-bus	<b>CTMT9410</b>	24V Input, to refresh E-bus	0
<b>Encoder Terminals</b>			
1-channel encoder interface, differential inputs	<b>CTMT5101</b>	Incremental encoder interface 5 V DC RS422 (TTL)	130
1-channel encoder interface	<b>CTMT5151</b>	Incremental encoder interface 24 V DC	130

### NUM EtherCAT product identification

CTMx: Communication to machine

CTMG: Gateway

CTMT: Terminals

<sup>1</sup> Dedicated option required: FPSW282312



### Ordering Code

---

NUM's EtherCAT terminals usually have an 8-digit identifier, which is printed on the device or attached to it on a sticker.

#### CTMx xxxx

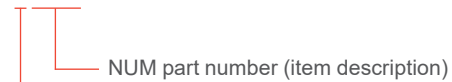

- G = Gateway
- T = Terminal
- P = Safe PLC
- S = Safe Terminal

### Example

---

Example of EtherCAT Gateway Terminal **CTMG1100**

- **CTM** Structure of production
- **G** Gateway identification
- **1100** Part number

Please also refer to the previous page for more detailed information.

### Technical Data

For detailed technical information about NUM's CTMG or CTMT EtherCAT terminals, please refer to reference manual M00032EN-00.

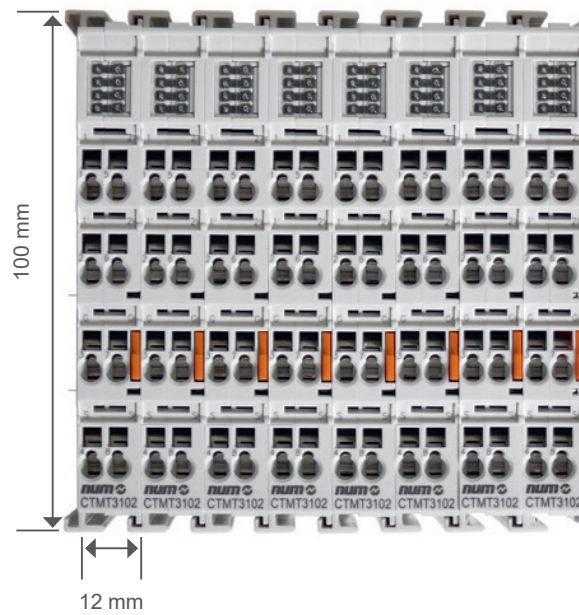

Note 1:

Nearly all types of CTMT terminals have the same dimensions.

Note 2:

NUM's CTMG and CTMT EtherCAT terminals are available from stock. For information about particular logic components, or to check their availability, please contact your local NUM sales office.





### Main Accessories Overview

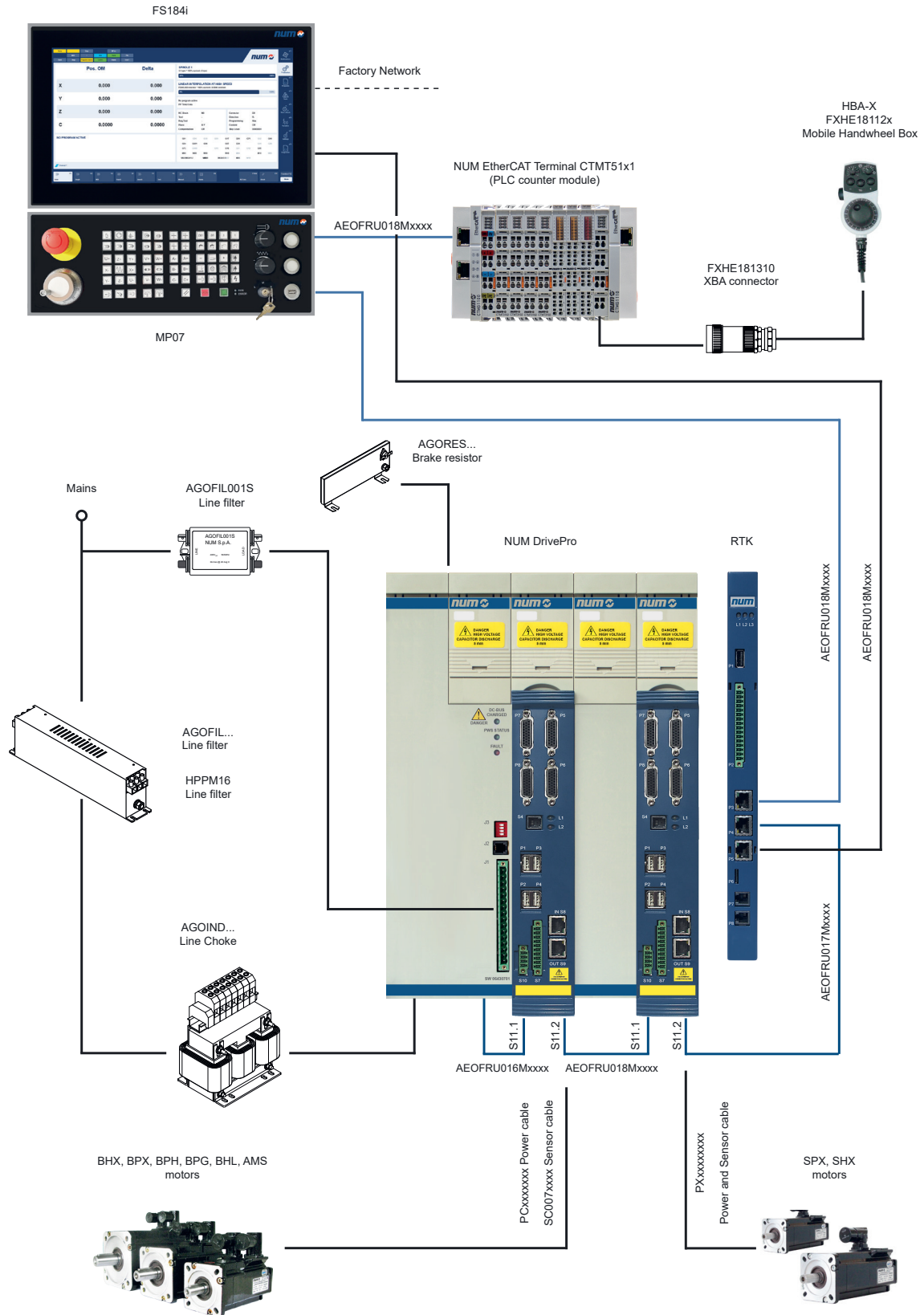

### NUM DrivePro with NUM-SAMX Module

NUM FlexiumPro  
RTK CNC and PLC

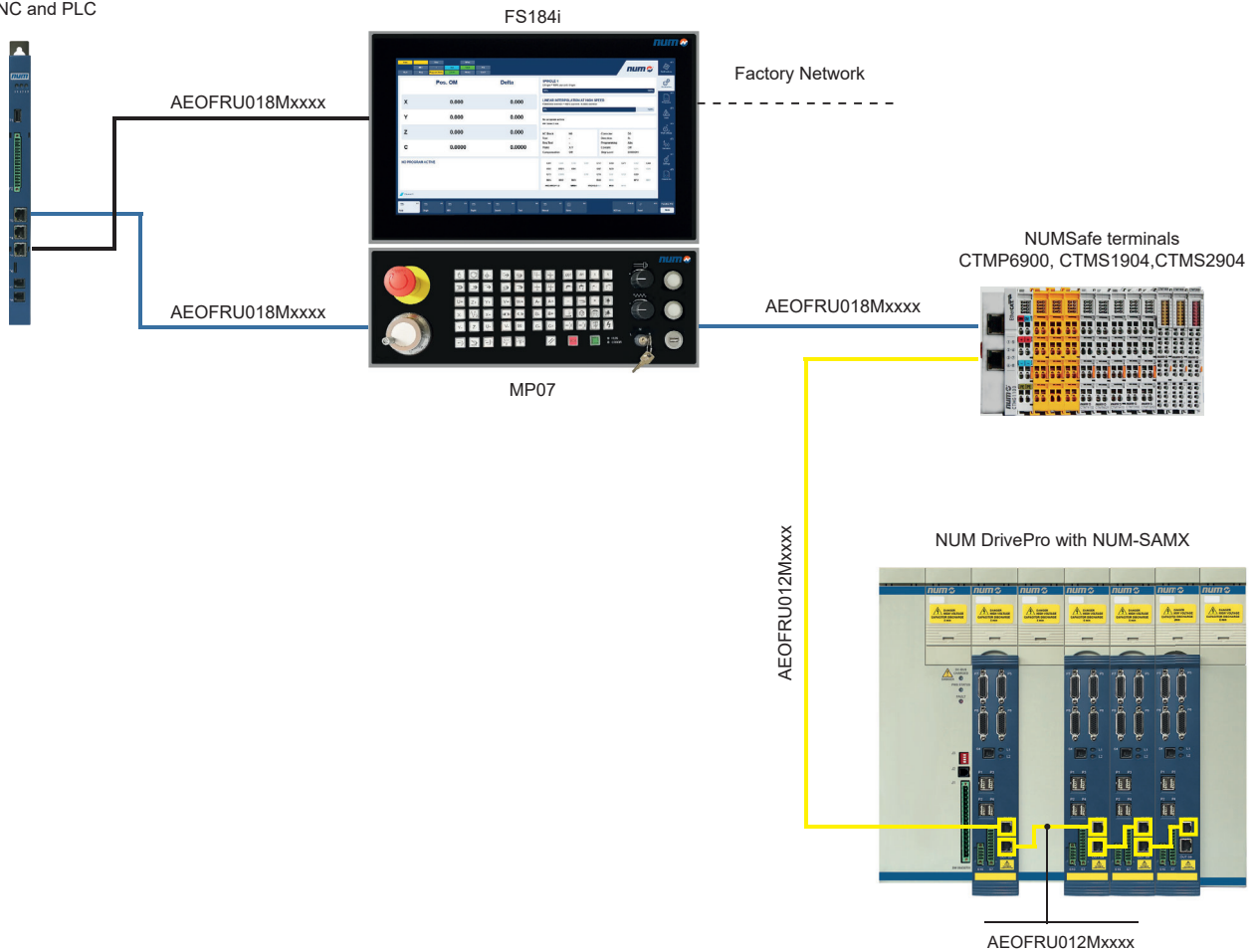



### NUM DrivePro with NUM-STOX Module

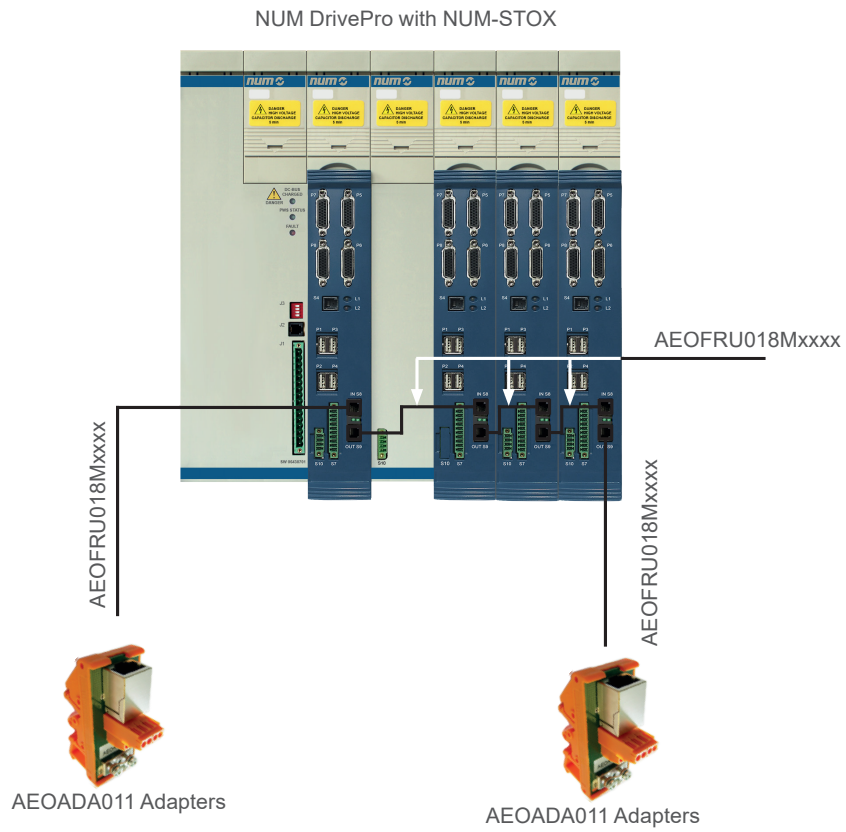

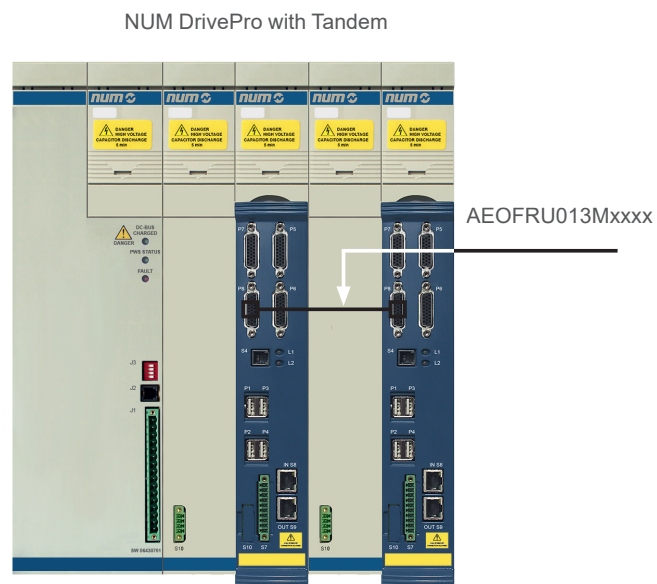

### NUM DrivePro with Tandem Application





### System Cables

Accessories	Order Code	Description	
RTK to MDLUF Cable	AEOFRU017M0006 AEOFRU017M0010 AEOFRU017M0025 AEOFRU017M0050	0.6 m length 1 m length 2.5 m length 5 m length	
CAN Cable PVC, Purple, Shielded in Pairs	FXHC181060	Cable only. Required length must be specified in the order.	







### System Cables

Accessories	Order Code	Description	
MDLL3 / MDLUF	AEOFRU016M0002 AEOFRU016M0003 AEOFRU016M0004	MDLUF size 1- 2 MDLUF size 3 MDLUF size 4 - 6	
EtherCAT Cable (yellow RJ45) for NUM-SAMX Connections	AEOFRU012M0001 AEOFRU012M0002 AEOFRU012M00A2 AEOFRU012M0003 AEOFRU012M0004 AEOFRU012M0015 AEOFRU012M0020 AEOFRU012M0030	MDLUF size 1 MDLUF size 2 MDLUF size 3 MDLUF size 4 MDLUF size 6 Cable length 1.5 m Cable length 2 m Cable length 3m	
Cable for Tandem: • Anti-Backlash • Torque Duplication • Winding Duplication	AEOFRU013M0001 AEOFRU013M0002 AEOFRU013M00A2 AEOFRU013M0003 AEOFRU013M0004	MDLUF size 1 MDLUF size 2 MDLUF size 3 MDLUF size 4 MDLUF size 6	
Ethernet cable (RJ45) for: MDLUF to MDLUF, NUM-STOX to NUM-STOX, RTK to PC, EtherCAT Gateway interconnection, RTK to EtherCAT Gateway	AEOFRU018M0001 AEOFRU018M0002 AEOFRU018M00A2 AEOFRU018M0003 AEOFRU018M0004 AEOFRU018M0010 AEOFRU018M0025 AEOFRU018M0050 AEOFRU018M0100	MDLUF size 1 MDLUF size 2 MDLUF size 3 MDLUF size 4 MDLUF size 6 Cable length 1 m Cable length 2.5 m Cable length 5 m Cable length 10 m	

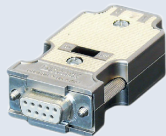

### System Connectors

Accessories	Order Code	Description	
CAN Connector	FXHE181200	CAN female connector axial with integrated bus termination	
CAN Connector	FXHE181201	CAN female connector 90°	
CAN Connector	FXHE181202	CAN male/female connector 90° with prog. unit	
Vibration detector connector	AEOCON016	Suitable for Vibration Detector VDX1002A00AC000	





### NUM DrivePro Connectors Kit

Accessories	Order Code	Description	
MDLUF Size 1 Power and Brake Connector	AEOCON018	<p>Suitable for: MDLUF007AExxN0I MDLUF014AExxN0I MDLUF021AExxN0I MDLUF034AExxN0I MDLUF007BExxN0I MDLUF014BExxN0I MDLUF021BExxN0I MDLUF014DExxN0I</p> <p>Drive power connector with polarization key.</p>	
MDLUF General Purpose Sensor Connector (P5, P6, P7, P8)	AEOCON012	<p>Suitable for all MDLUF</p> <p>Sensor connector Sub D HD 26 pin M. (4/40" screw thread connector).</p>	
MDLUF Size 2 and 3 Power and Brake Connector	AEOCON013	<p>Suitable for: MDLUF050AExxN0I MDLUF075AExxN0I MDLUF100AExxN0I MDLUF050BExxN0I MDLUF075BExxN0I</p> <p>Drive power connector, brake connectors + fixing device, metallic strip and polarization keys.</p>	
MDLUF Size 3 Power and Brake Connector	AEOCON015	<p>Suitable for: MDLUF150AExxN0I</p> <p>Drive power connector, brake connectors + fixing device, metallic strip and polarization keys.</p>	
MDLUF Sensor Connector for Single Cable Motor (P1, P2, P3, P4)	AEOCON019	<p>Suitable for all MDLUF Industrial USB</p>	



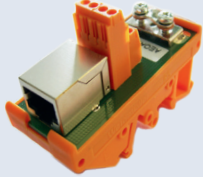

### NUM DrivePro Adapters

Accessories	Order Code	Description	
RJ45 NUM-STOX Cable to Terminal Adapter	AEOADA011	NUM-STOX adapter with wire terminal connections (8 screw terminals)	



### MDLL3 Size 6 Power Supply Connection Kit

Accessories	Order Code	Description
MDLL3120N00AN0I MDLL3120N00RN0I MDLL3120N00HN0I Power Supply Connection Kit	AEOKIT003	Mandatory connection kit. See figure.

#### AEOKIT003



Metallic strip 50 mm for DC Bus



Self locking nut M8



Self locking nut M3



Eyebolt M8

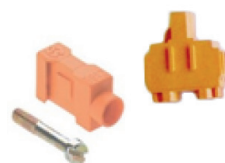

Plug connector AUX



Metallic strip



16 pin connector



Plastic protection



Shell for 16 pin connector



Metallic plate for cable and shield fixing

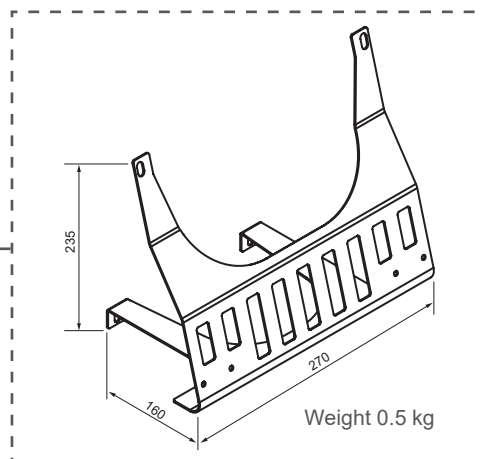



### MDLUF Size 6 Drive Connection Kit

Accessories	Order Code	Description
MDLUF400AExxN01 Drive Connection Kit	AEOKIT006	Mandatory connection kit. See figure.



Metallic strip 50 mm for DC Bus



Self locking nut M8



Self locking nut M3



Eyebolt M8



Plug connector AUX



Metallic strip



Brace connector



Plastic protection



10 pin connector



Metallic plate for cable and shield fixing

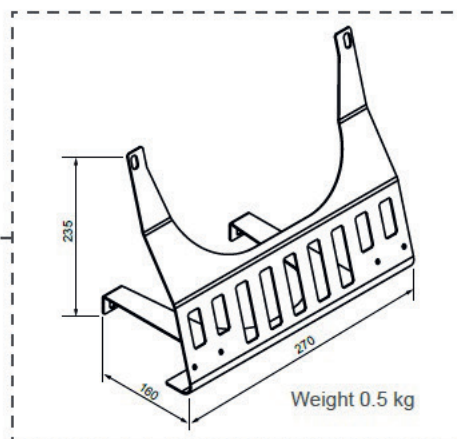



### Fan Kit for NUM DrivePro Size 6 AGOFAN001

Accessories	Order Code	Description
Fan Module	AGOFAN001	Mandatory for: MDLL3120N00HN0I MDLL3120N00AN0I MDLL3120N00RN0I MDLUF400AExxN0I

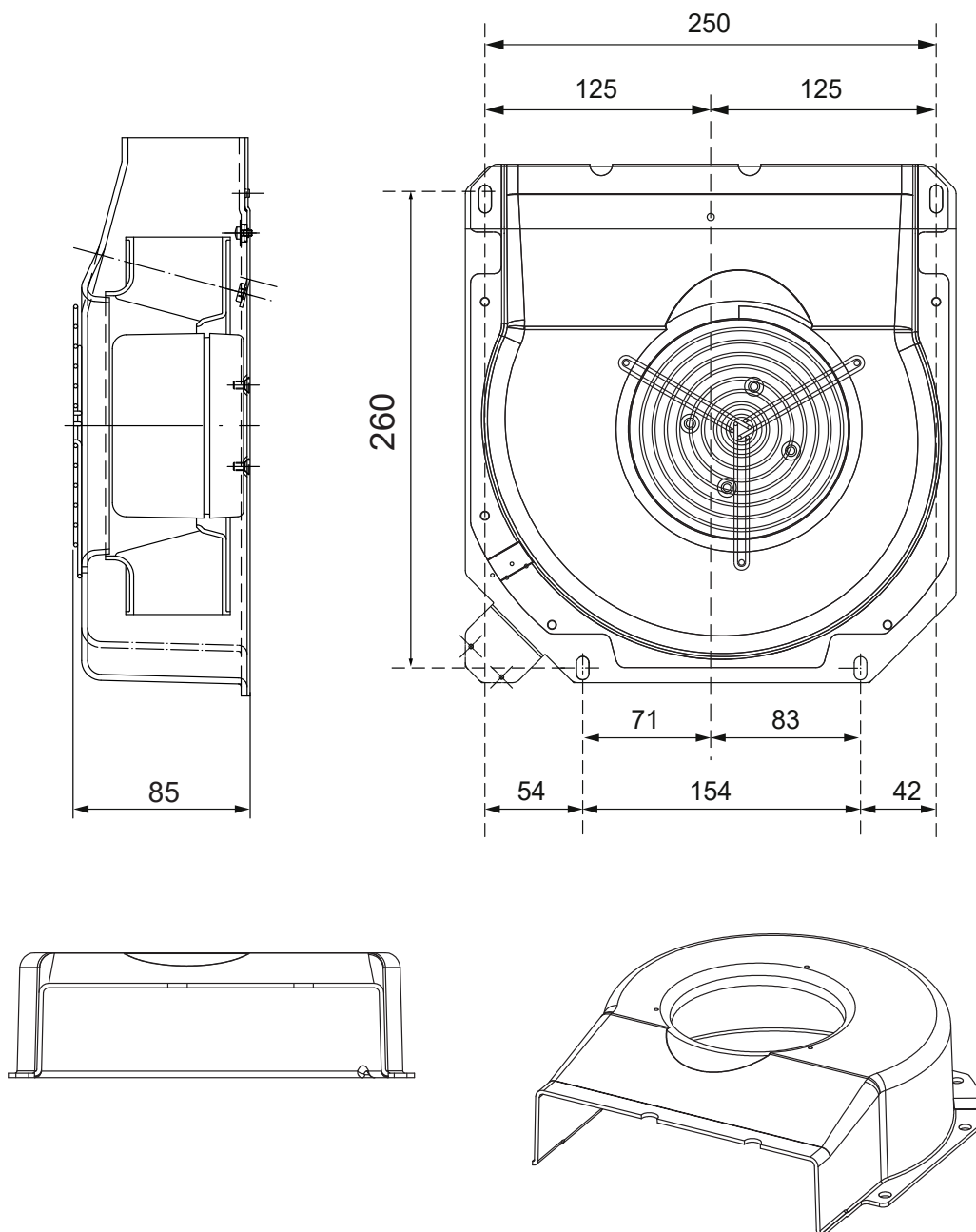



### Socket for Portable Handwheel HBA-X FXHE181310

Accessories	Order Code	Description
Socket for Portable HBA-X	FXHE181310	XBA-X connector Please also refer to "Main accessories overview" section.

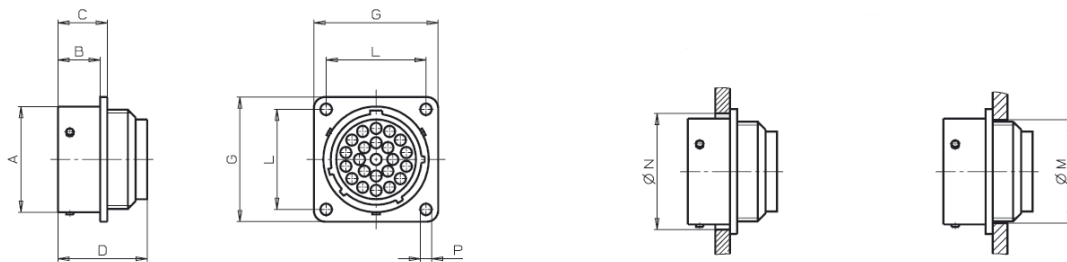
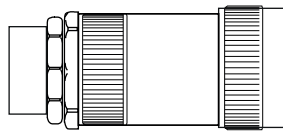



### Overview Power Supply and Accessories

Power Supply MDLL	Line Filter 1	Line Filter 2: Auxillary Power Supply	Line Filter 3	Line Choke	Fan Module	Power Supply Connection Kit
MDLL3005M00AN0I	AGOFIL028	AGOFIL001S				
MDLL3015N00AN0I	AGOFIL024A	AGOFIL001S				
MDLL3025N00RN0I	AGOFIL026	AGOFIL001S	HPPM166	AGOIND006		
MDLL3025N00HN0I	AGOFIL026	AGOFIL001S	HPPM166	AGOIND001		
MDLL3030N00AN0I	AGOFIL025A	AGOFIL001S				
MDLL3050N00AN0I	AGOFIL026	AGOFIL001S		AGOIND007		
MDLL3050N00RN0I	AGOFIL026	AGOFIL001S	HPPM166	AGOIND007		
MDLL3050N00HN0I	AGOFIL026	AGOFIL001S	HPPM166	AGOIND002		
MDLL3120N00AN0I	AGOFIL027	AGOFIL001S		AGOIND009	AGOFAN001	AEOKIT003
MDLL3120N00RN0I	AGOFIL027	AGOFIL001S	HPPM166	AGOIND009	AGOFAN001	AEOKIT003
MDLL3120N00HN0I	AGOFIL027	AGOFIL001S	HPPM166	AGOIND009	AGOFAN001	AEOKIT003
MDLQ3001N00		AGOFIL001S				



### Line Filter AGOFIL024A, 025A, 026, 027

Technical Data	AGOFIL024A	AGOFIL025A	AGOFIL026	AGOFIL027
MDLL3 Association	MDLL3015N00AN0I	MDLL3030N00AN0I	MDLL3025N00RN0I MDLL3025N00HN0I MDLL3050N00AN0I MDLL3050N00RN0I MDLL3050N00HN0I	MDLL3120N00AN0I MDLL3120N00RN0I MDLL3120N00HN0I
Rated Voltage	480 VAC 50/60 Hz			
Rated Current (refer. to 50°C amb. temp)	42 Arms	75 Arms	100 Arms	180 Arms
Test Voltage	3470 VDC, 2s (line to ground) 1700 VDC, 2s (line to line)			
Leakage Current	Normal condition < 3mA Fault condition 260mA (only one phase remaining)			
Standard	EN61800-3 category C3 - I <100mA (second environment (industrial low-voltage supply network))			
Terminal Block Cross Section: LINE/LOAD	10 mm <sup>2</sup>	16 mm <sup>2</sup>	50 mm <sup>2</sup>	95 mm <sup>2</sup>
Weight	2.8 kg	4.4 kg	4.7 kg	7.5 kg

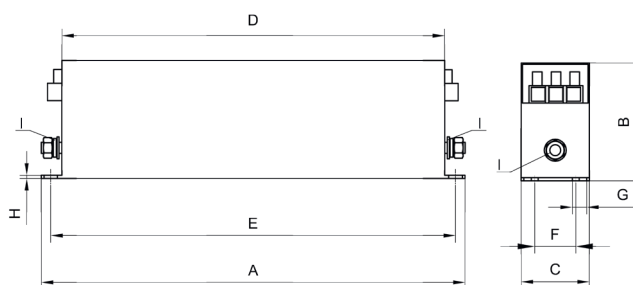

(I) Earth point connections (M6 or M10). Screw tightening torque: 1.9 - 2.1 Nm.

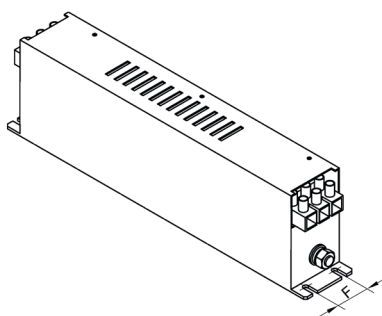

Line Filter	A	B	C	D	E	F	G	H	I
AGOFIL024A	310	85	50	280	395	30	5.4	2	M6
AGOFIL025A	270	135	80	240	255	60	6.5	3	M6
AGOFIL026	270	150	90	240	255	65	6.5	3	M10
AGOFIL027	380	170	120	350	362	102	6.5	3	M10

10





### Line Filter AGOFIL028

Technical Data	AGOFIL028
MDLL3	MDLL3005M00AN01
Rated Voltage	250 VAC 50/60Hz
Rated Current (refer. to 40°C amb. temp)	20 A
Terminal Cross Section	Faston 6.3 x 0.8 mm
Weight	0.3 kg

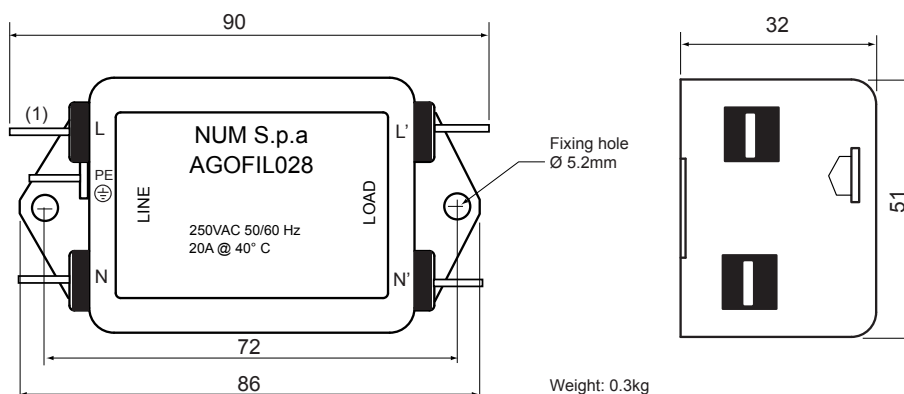

(1) Terminal cross section: Faston 6.3x0.8mm





### Filter AGOFIL001S for Auxiliary Power Supply (mandatory for all power supplies)

Technical Data	AGOFIL001S
MDLL3, MDLQ Association	All MDLL3 and MDLQ power supply
Rated Voltage	480 VAC 50/60 Hz
Rated Current (refer. to 40°C amb. temp)	3 A
Leakage Current	0.5 mA
Terminal Cross Section	Faston 6.3 x 0.8 mm
Weight	0.3 kg

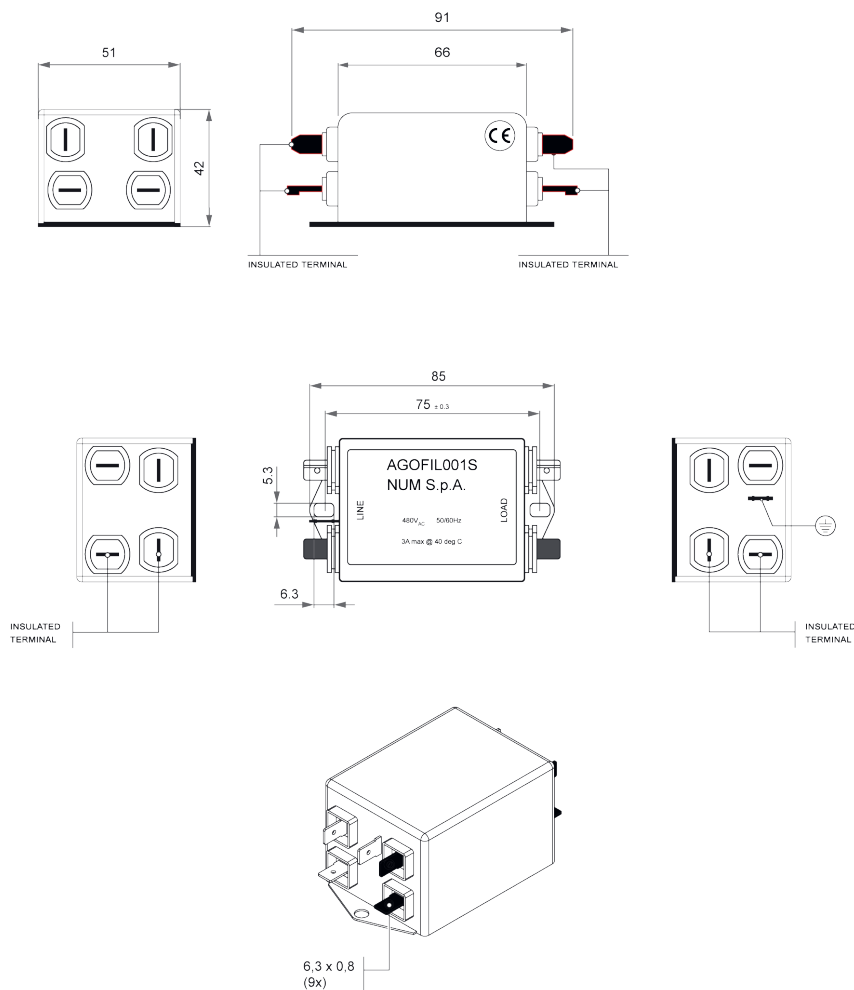



### Line Filter HPPM166

Technical Data	HPPM166
MDLL3 Association	MDLL3025N00HNOI MDLL3050N00HNOI MDLL3025N00RNOI MDLL3050N00RNOI MDLL3120N00RNOI MDLL3120N00HNOI
Rated Voltage	440 VAC 50/60 Hz
Rated Current	20 A
Capacitance	3 x 16.6 $\mu$ F
Terminal Connections	M8 bolt
Weight	1.2 kg

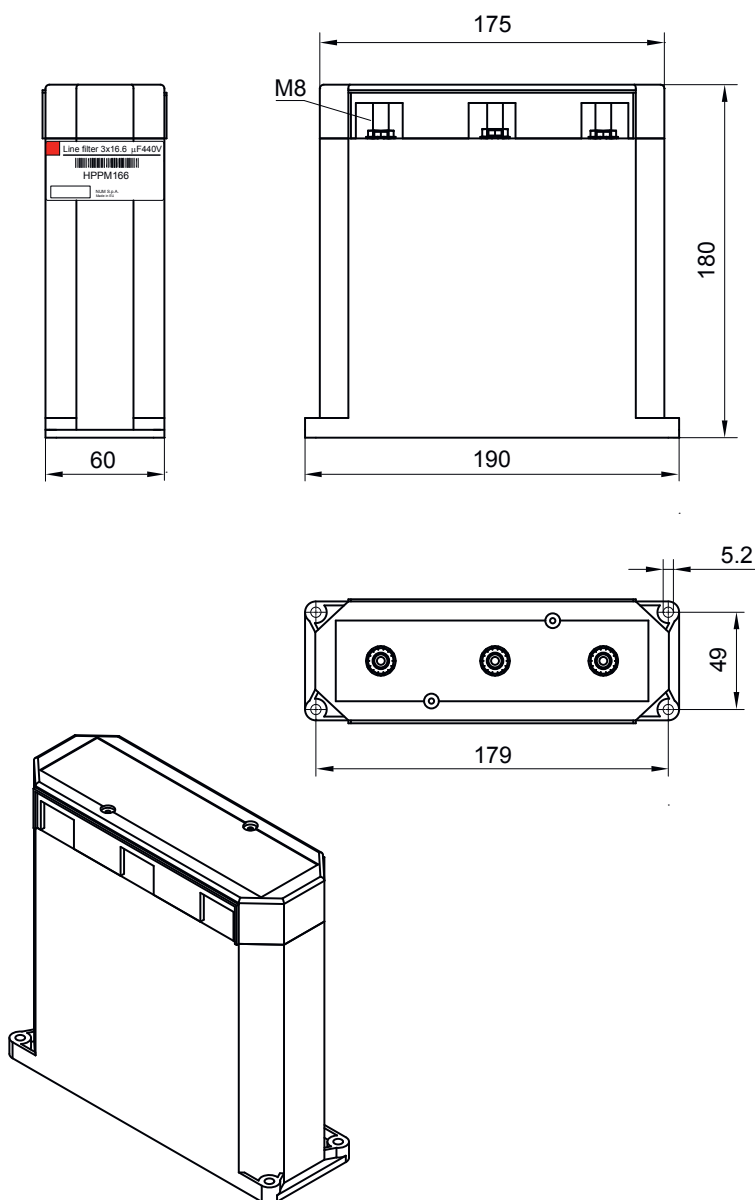



### Line Chokes

Line Choke	AGOIND001	AGOIND002	AGOIND006	AGOIND007	AGOIND009
MDLL3..... Association	...025N00HN0I	...050N00HN0I	...025N00RN0I	...050N00AN0I ...050N00RN0I	...120N00AN0I ...120N00RN0I ...120N00HN0I
Rated Voltage	67 Arms	103 Arms	60 Arms	100 Arms	210 Arms
Inductance	0.45 mH	0.27 mH	0.5 mH	0.3 mH	0.15 mH
Losses	250 W	350 W	94 W	260 W	300 W
Degree of Protection	IP00				
Weight	13 kg	18 kg	11 kg	16 kg	56 kg

AGOIND001 and AGOIND002 - Overall Dimensions

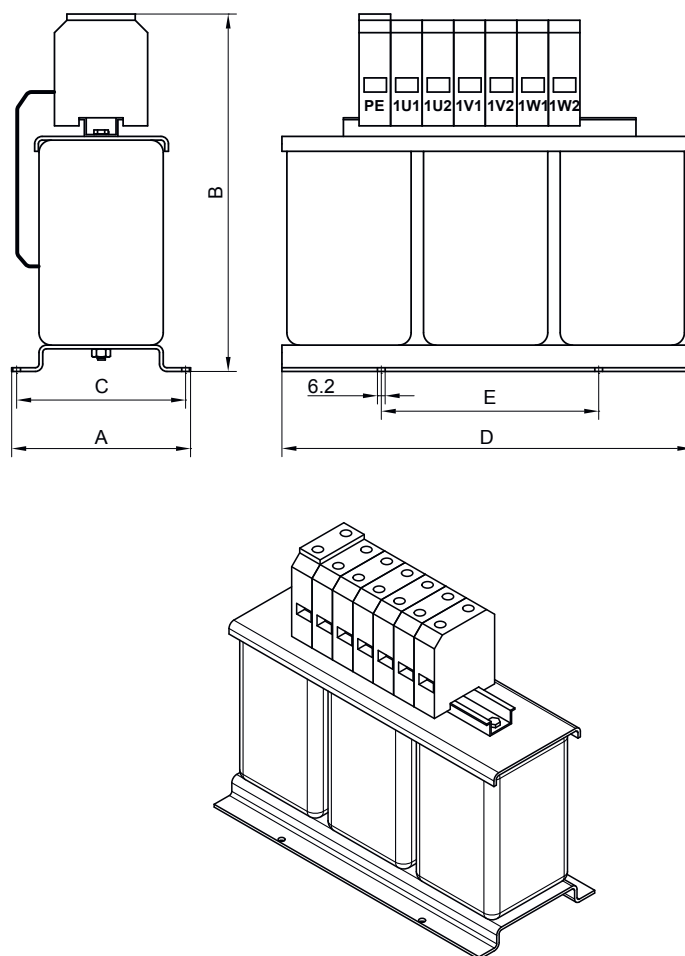

10

Line Choke	A	B	C	D	E	Terminal Block Cross Section
AGOIND001	150	230	136	330	175	35 mm <sup>2</sup>
AGOIND002	150	280	136	330	175	50 mm <sup>2</sup>



### Line Chokes Overall Dimensions

AGOIND006 - Overall Dimensions

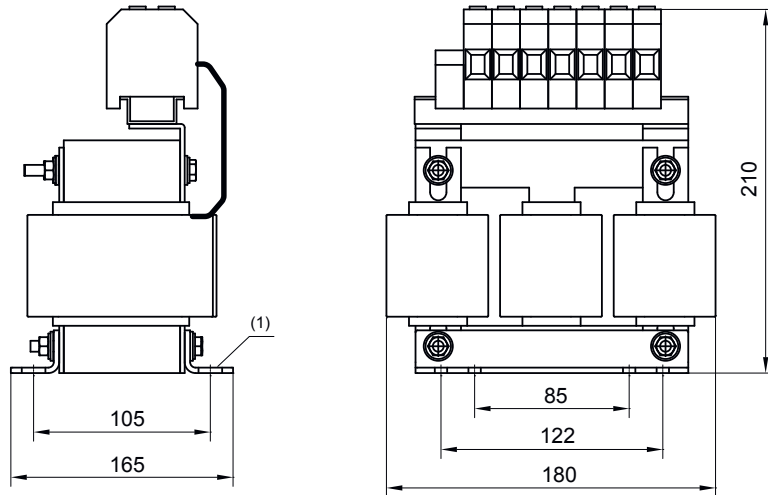

(1) 8x (Ø6x12)

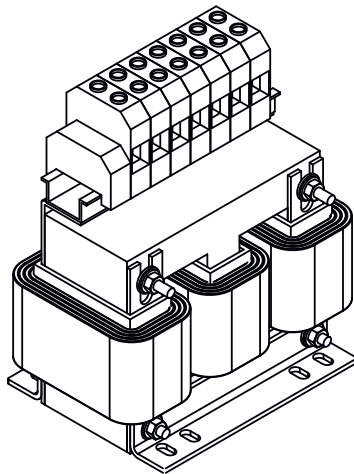



### Line Chokes Overall Dimensions

AGOIND007 - Overall Dimensions

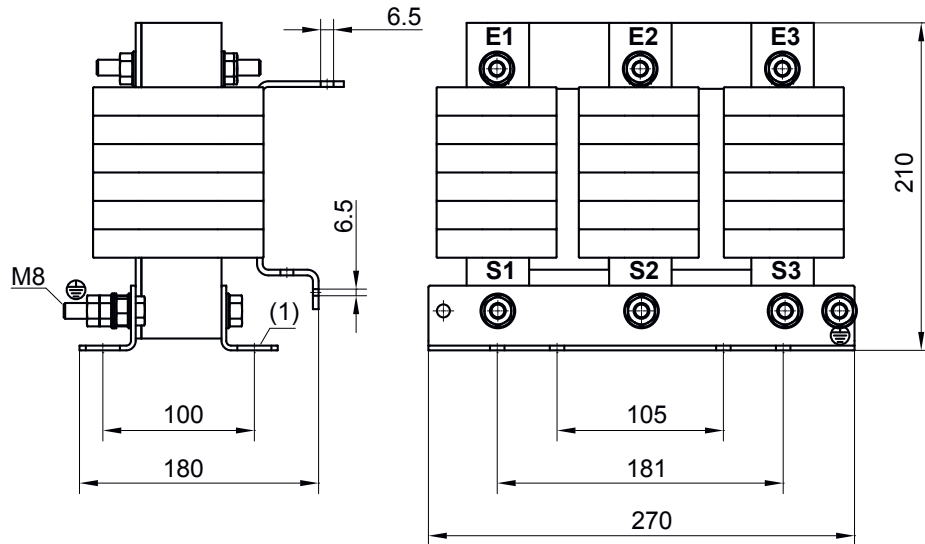

(1) 8x (Ø11x22)

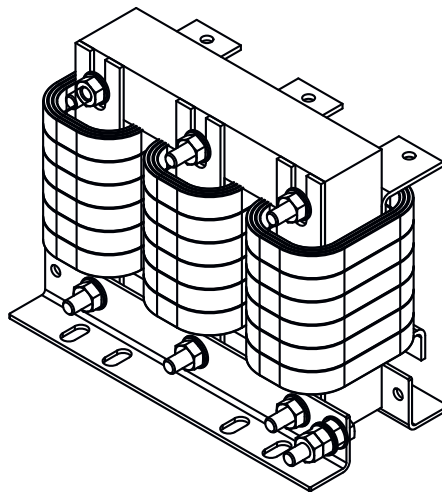



### Line Chokes Overall Dimensions

AGOIND009 - Overall Dimensions

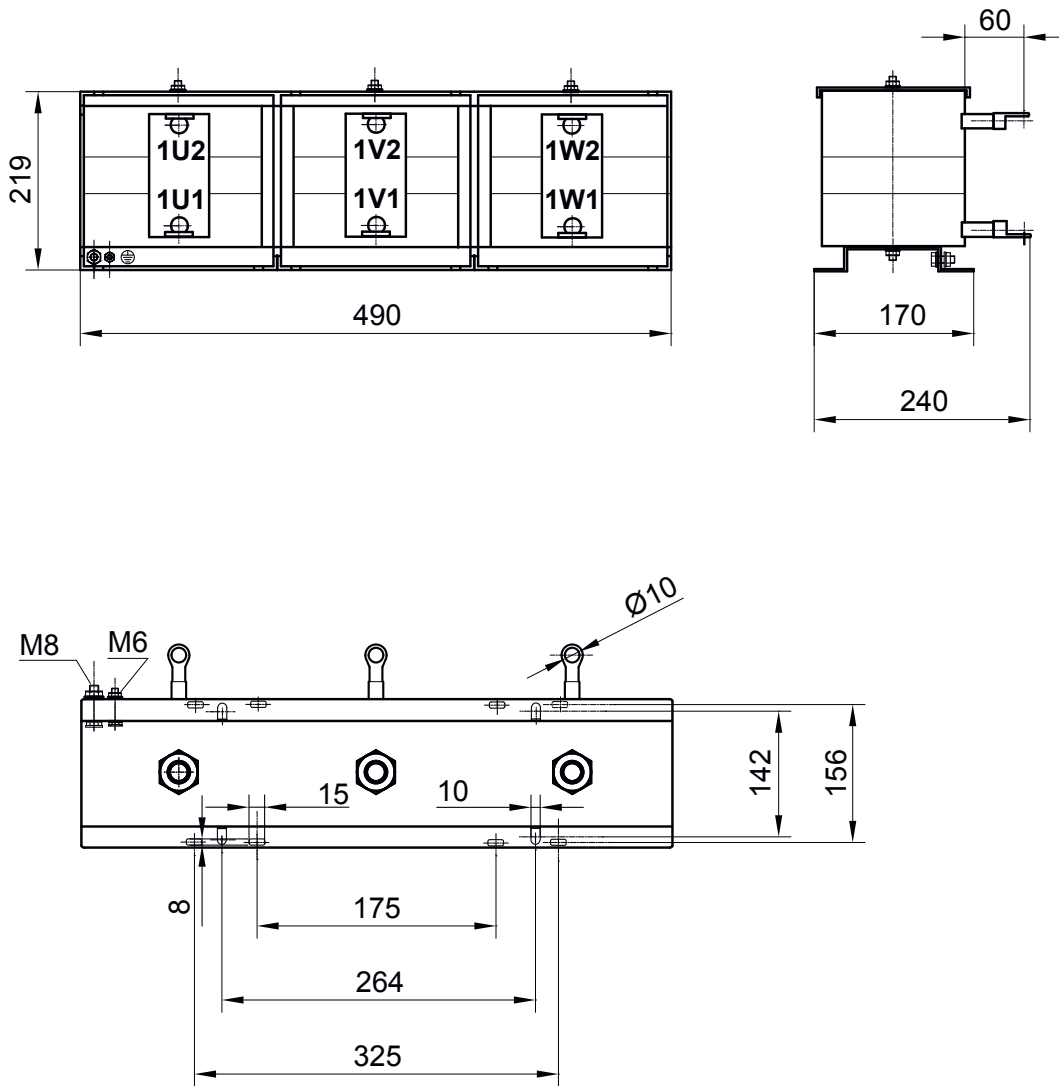







### Braking Resistor

External Braking Resistor	AGORES008	AGORES009	AGORES010	AGORES011
Continuous Nominal Power (Environment Temperature 40°C)	480 W	480 W	2500 W	2500 W
Resistive Value	17 Ω	8.5 Ω	5.6 Ω	8.5 Ω
Resistor Thermal Protection by means of Thermal Switches	Thermal switch 1 fitted on the frame with N.C contact Contact interruption 10A/250 VAC Contact open >400°C for AGORES008/9 Contact open >160 °C for AGORES010/011			
Energy Pulse <500 ms	12 kJ	12 kJ	125 kJ	125 kJ
Weight	0.35 kg	0.35 kg	5.6 kg	5.6 kg

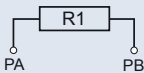
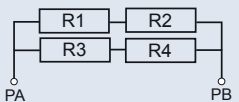
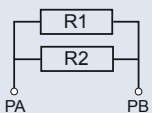

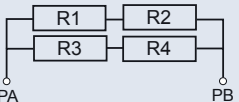
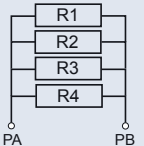
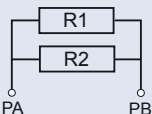
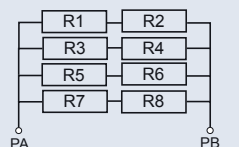

### Braking Resistor Operating Examples

MDLL3 Association	Braking Resistor	Connection Configuration	Value [ $\Omega$ ]	P cont. [W]	Peak Power <100ms [kW]
MDLL3015N00AN01 MDLL3005M00AN01	AGORES008		17	480	30
	AGORES008 (X4)			1920	30
MDLL3030N00AN01 MDLL3025N00RN01 MDLL3025N00HN01	AGORES008 (X2)		8.5	960	61
	AGORES009			480	61
	AGORES009 (X4)			1920	61
MDLL3050N00RN01 MDLL3050N00HN01	AGORES008 (X4)		4.25	1920	120
	AGORES009 (X2) Basic Configuration			960	120
	AGORES009 (X8)			3840	120
	AGORES010			2500	100



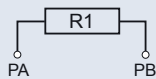
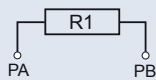
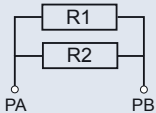
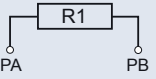
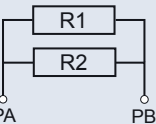
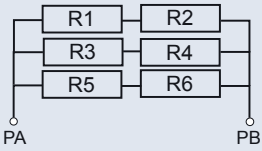
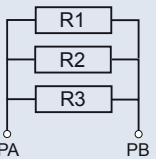

### Braking Resistor Operating Examples

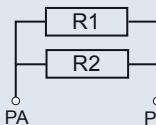
MDLL3 Association	Braking Resistor	Connection Configuration	Value [ $\Omega$ ]	P cont. [W]	Peak Power <100ms [kW]
MDLL3050N00AN01	AGORES010		5.6	2500	100
	AGORES011		8.5	2500	60
	AGORES011 (X2)		4.25	5000	120
MDLL3120N00HN01	AGORES010		5.6	2500	100 (Peak power <1s)
	AGORES010 (X2)		2.8	5000	200 (Peak power <1s)
MDLL3120N00AN01	AGORES010 (X6)		3.73	15000	120 (Peak power <2s)
	AGORES011 (X3)		2.8	7500	160 (Peak power <1s)
MDLL3120N00RN01	AGORES010		5.6	2500	100 (Peak power <1s)
	AGORES010 (X2)		2.8	5000	200 (Peak power <1s)

10



### Braking Resistor Overall Dimensions

AGORES008, AGORES009 - Overall Dimensions

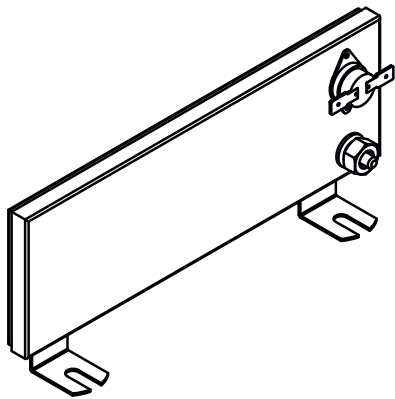
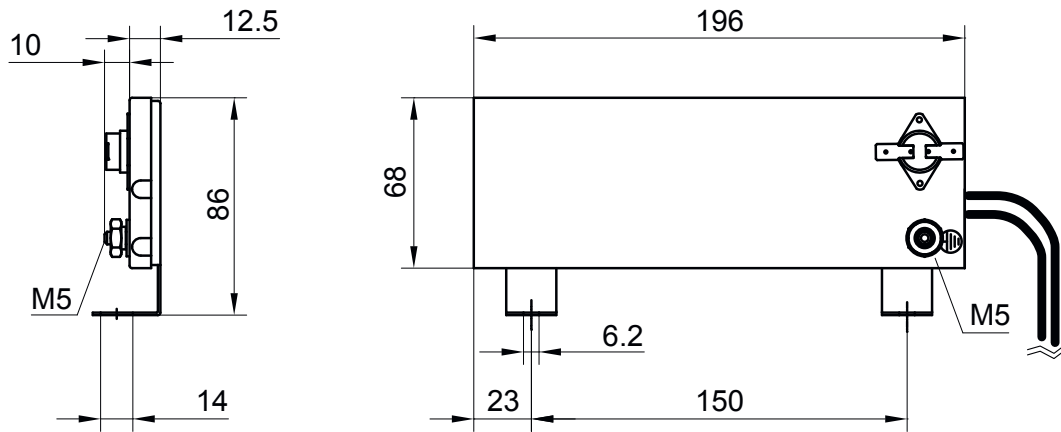



### Braking Resistor Overall Dimensions

AGORES010, AGORES011 - Overall Dimensions

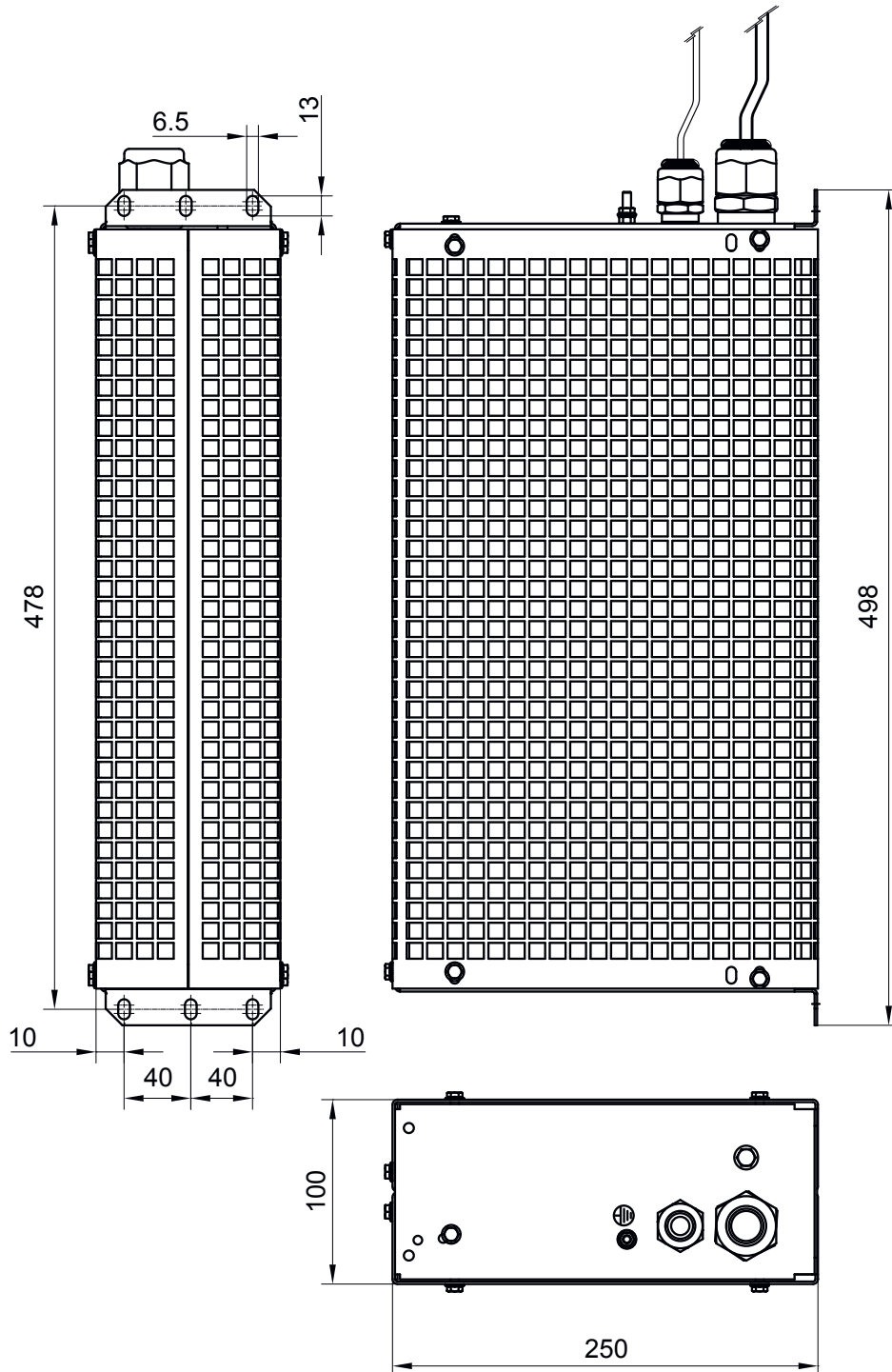

## Vibration Detector (VDR)



### Vibration Detector (VDR)

NUM vibration detector (accelerometer) can be directly connected to NUM DrivePro and it's sampled at 50 microseconds; it can be used in for different applications:

- Cost effective solution for implementing an active damping close loop function (without the need of a machine sensor like linear scale).
- Dumping the tool center point vibrations
- Use the acceleration information to optimize the milling/turning process (avoid chattering for example)
- Detect and log machine crashes
- Estimate tool life and tool breakage even associated with NUMmonitor
- Detect spindle vibrations (bearing issues)
- Detect mechanical backlash
- Compensate cross-axes deformation

Technical Data	VDX1002A00AC000
Acceleration range	±2g
Direction of measurement	mono-axis, normal to mounting plane
Max measurable frequency	2 kHz
Output signal type	analogue (differential) 1 Vpp
Max output	60% of 1 Vpp at 2g
Power supply input	8+15V
Working temperature range	0-85 °C
Storage temperature range	0+100°C
Case material	aluminium
Weight	~55g
Mounting	2 screws M4x30 ISO4762 (DIN912)
Protection degree	IP67 (with plugged female connector)

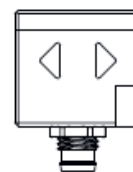
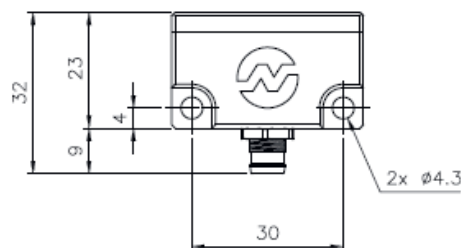
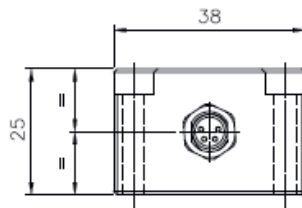



### Auto-Transformer for BHL260 Fan (with 460V Network)

Technical Data	AMOTRF001
Rated Power	500 VA
Input / Output Voltage	460 Vrms / 400 Vrms 3phases
Frequency	50/60 Hz
Protection Class as per EN60529	IP00
Weight	2.8 kg

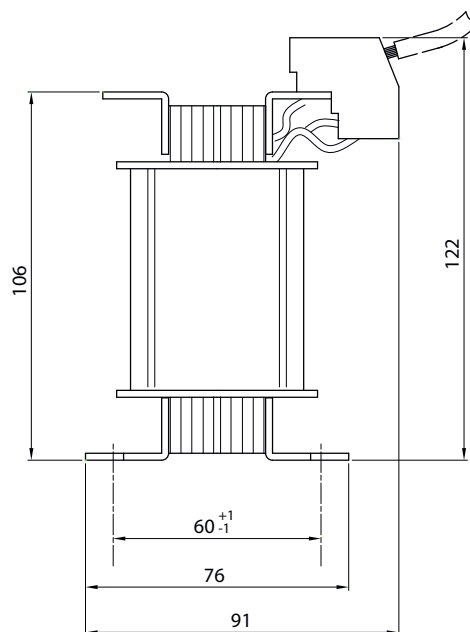
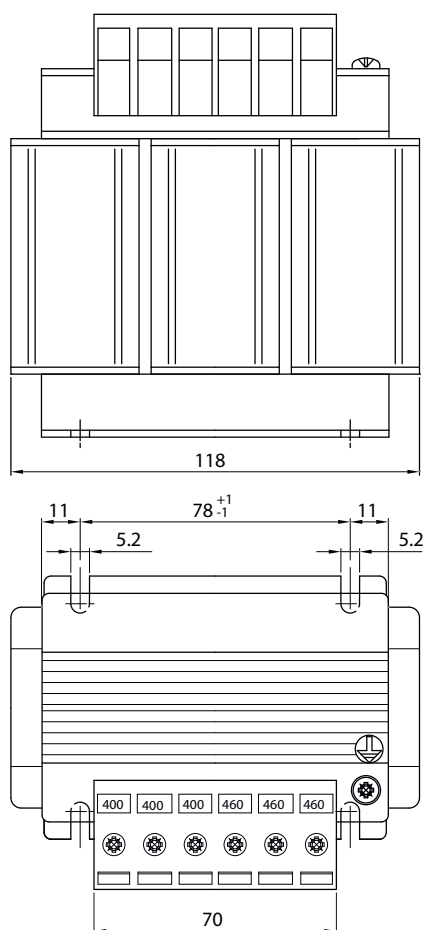

10



### MDLC3010N00

Technical Data	MDLC3010N00
Rated input voltage	420 to 700 VDC
Module capacity	8250 $\mu$ F
Weight	6 kg

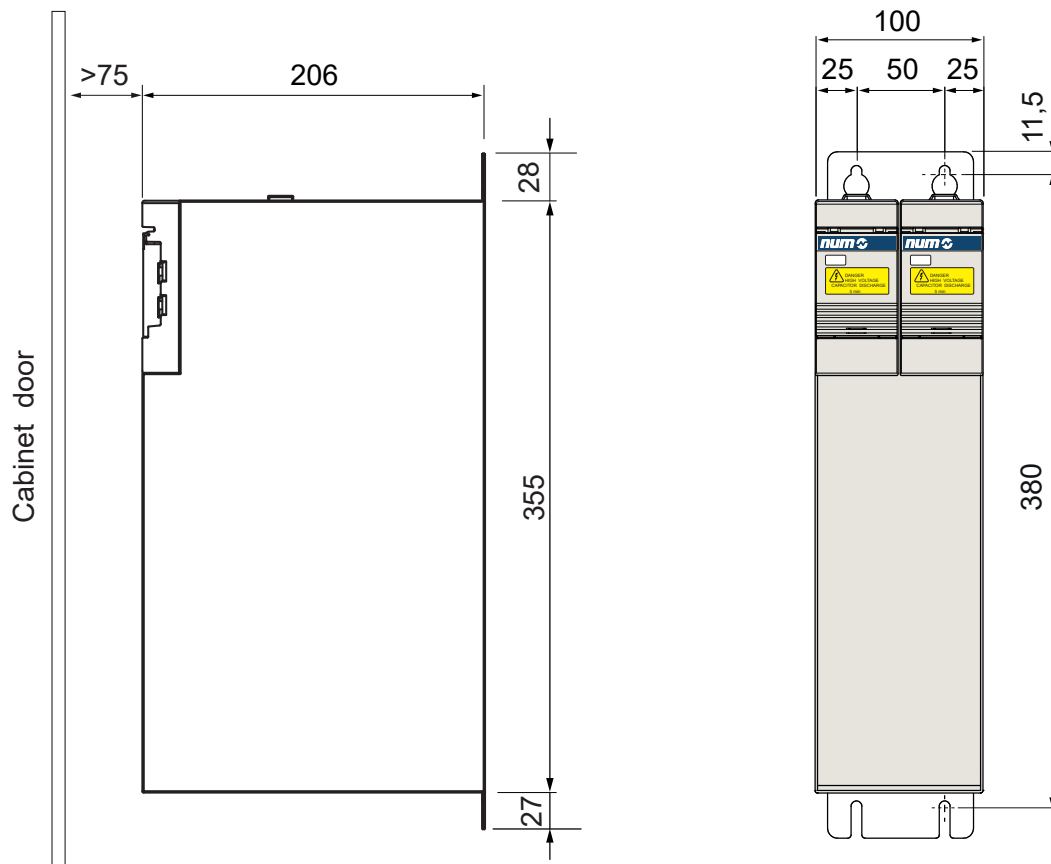



### Motor Cables

The cables are available with different conductor sizes, characteristics and compositions. Options include High Performance and Basic Performance power cables, as well as combined power/sensor cables for use with SHX and SPX motors.

The cables comply with with UL and cUL recognized, DESINA and EC standards:

- Multi-strand conductors provide flexibility for movement
- The motor thermal probe is connected by the sensor motor cable
- The brake is connected by the power cable
- The connection between the power / sensor cable and the moving part of the connector must be made using the crimping tool

### High Performance Power Cables

Cable Code	Brake Wires	Cable Composition	External Diameter (mm)
PC015BH00	Yes	(([3+T] x 1.5 mm <sup>2</sup> + (2x1.5 mm <sup>2</sup> ))	11.8 ± 0.5
PC040BH00	Yes	(([3+T] x 4 mm <sup>2</sup> + (2x1.5 mm <sup>2</sup> ))	14.4 ± 0.6
PC060BH00	Yes	(([3+T] x 6 mm <sup>2</sup> + (2x1.5 mm <sup>2</sup> ))	16.3 ± 0.7
PC100BH00	Yes	(([3+T] x 10 mm <sup>2</sup> + (2x1.5 mm <sup>2</sup> ))	19.2 ± 0.8
PC215BH00	Yes	(([3+T] x AWG04 + (2x1.5 mm <sup>2</sup> ))	24.7 ± 0.9
PC015NH00	No	(([3+T] x 1.5 mm <sup>2</sup> )	10.6 ± 0.5
PC040NH00	No	(([3+T] x 4 mm <sup>2</sup> )	13.2 ± 0.6
PC100NH00	No	(([3+T] x 10 mm <sup>2</sup> )	18.1 ± 0.8

<b>Operating Temperature</b>	-30°C ... to + 80°C
<b>Storage Temperature</b>	-50°C ... to + 80°C
<b>Nominal Voltage</b>	Power: U <sub>0</sub> /U = 0.6/1KV (VDE), U = 1000V (UL AWM/CSA AWM), Brake U = 24V (VDE)
<b>Bending Radius (Dynamic)</b>	≥ 7.5 x external diameter
<b>Bending Radius (Static)</b>	≥ 4 x external diameter
<b>Maximum Speed</b>	300 m/min
<b>Maximum Acceleration</b>	50 m/sec <sup>2</sup>
<b>Cycles</b>	10.000.000
<b>Torsion max</b>	+/- 30°/m
<b>Pulling Force (Dynamic)</b>	≤ 20 N/mm <sup>2</sup>
<b>Pulling Force (Static)</b>	≤ 50 N/mm <sup>2</sup>
<b>Capacitance [pF/m] Power</b> • Conductor/Conductor • Conductor/Shield	sec. 1.5-2.5 mm <sup>2</sup> <90 (Typical 80), sec. 4.0-6.0 mm <sup>2</sup> <110 (Typical 90) <160 (Typical 130), <180 (Typical 140)
<b>Capacitance [pF/m] Brake</b> • Conductor/Conductor • Conductor/Shield	sec. 1.5 mm <sup>2</sup> <120 (Typical 100) <200 (Typical 170)
<b>Oil Resistant</b>	HD 22.10 S2 (VDE 0282 p.10)//VDE 0472 p.803 B//EN 60811.2.1
<b>Flame Resistant</b>	EN 60332-1-1 // EN 60332-1-3 // FT1// UL 1581 sce.1061//EN 50265.2.1
<b>UL/CSA LISTED, DESINA</b>	Yes
<b>Jacket Colour</b>	PUR - Orange - RAL2003
<b>Resistivity of Cable at 20°C [Ohm/km]</b>	1.5 mm <sup>2</sup> = 13.3, 4 mm <sup>2</sup> = 4.95, 6 mm <sup>2</sup> = 3.3, 10 mm <sup>2</sup> = 1.91, 21 mm <sup>2</sup> = 0.83
<b>Max Useful Length</b>	75 m



### High Performance Power Cables for Single Cable Motor

Cable Code	Brake Wires	Cable Composition	External Diameter (mm)
PX007BH00	Yes	(3 x 0.75 mm <sup>2</sup> ) + T x 0.75 mm <sup>2</sup> + (2x0.75 mm <sup>2</sup> ) + (2x AWG26)	12 ± 0.5
PX015BH00	Yes	(3 x 1.5 mm <sup>2</sup> ) + T x 1.5 mm <sup>2</sup> + (2x1.5 mm <sup>2</sup> ) + (2x AWG22)	14.4 ± 0.5

<b>Operating Temperature</b>	-40°C ... to + 80°C
<b>Storage Temperature</b>	-40°C ... to + 80°C
<b>Nominal Voltage</b>	Power: U <sub>o</sub> /U = 0.6/1KV (VDE) Brake U = 24V (VDE)
<b>Bending Radius (Dynamic)</b>	≥ 7.5 x external diameter
<b>Bending Radius (Static)</b>	≥ 5 x external diameter
<b>Maximum Speed</b>	300 m/min
<b>Maximum Acceleration</b>	50 m/sec <sup>2</sup>
<b>Cycles</b>	5.000.000
<b>Torsion max</b>	+/- 30°/m
<b>Pulling Force (Dynamic)</b>	≤ 20 N/mm <sup>2</sup>
<b>Pulling Force (Static)</b>	≤ 50 N/mm <sup>2</sup>
<b>Oil Resistant</b>	UL 1581 – VDE 0472 part 803 A/B
<b>Flame Resistant</b>	CEI 20-35-1-2 – EN 50265-1-2 – IEC 60332-1-2 – UL VW-1 – CSA FT1
<b>UL/CSA LISTED, DESINA</b>	Yes
<b>Jacket Colour</b>	PUR - Orange - RAL2003
<b>Resistivity of Cable at 20°C [Ohm/km]</b>	AWG26 ≤ 131 , 0.75mm <sup>2</sup> ≤ 39 AWG22 ≤ 59 , 1.50mm <sup>2</sup> ≤ 13.3
<b>Max Useful Length</b>	(PX007) 20 m (PX015) 75 m





### Basic Performance Power Cables

NUM Basic Performance cables are normally used where high flexibility is not strictly required.

Cable Code	Brake Wires	Cable Composition	External Diameter (mm)
PC015BL00	Yes	(([3+T] x 1.5 mm <sup>2</sup> + (2x1.5 mm <sup>2</sup> ))	10.4 ± 0.4
PC040BL00	Yes	(([3+T] x 4 mm <sup>2</sup> + (2x1.5 mm <sup>2</sup> ))	13 ± 0.5
PC015NL00	No	(([3+T] x 1.5 mm <sup>2</sup> )	8.1 ± 0.4
PC040NL00	No	(([3+T] x 4 mm <sup>2</sup> )	11.0 ± 0.5

<b>Operating Temperature</b>	-10°C ... to + 80°C
<b>Storage Temperature</b>	-20°C ... to + 80°C
<b>Nominal Voltage</b>	- Power : U <sub>o</sub> /U = 0.6/1KV (VDE) - U = 1000 V (UL AWM/CSA AWM) - Brake U = 24 V (VDE)
<b>Bending Radius (Dynamic)</b>	≥ 15 x external diameter
<b>Bending Radius (Static)</b>	≥ 5 x external diameter
<b>Maximum Speed</b>	30 m/min
<b>Maximum Acceleration</b>	2 m/sec <sup>2</sup>
<b>Cycles</b>	2.000.000
<b>Torsion max</b>	Not admitted
<b>Pulling Force (Dynamic)</b>	≤ 20 N/mm <sup>2</sup>
<b>Pulling Force (Static)</b>	≤ 50 N/mm <sup>2</sup>
<b>Capacitance [pF/m] Power</b> • Conductor/Conductor • Conductor/Shield	sec. 1.5-2.5 mm <sup>2</sup> <90 (Typical 80), sec. 4.0-6.0 mm <sup>2</sup> <110 (Typical 90) <160 (Typical 130), <180 (Typical 140)
<b>Capacitance [pF/m] Brake</b> • Conductor/Conductor • Conductor/Shield	sec. 1.5 mm <sup>2</sup> <120 (Typical 100) <200 (Typical 170)
<b>Oil Resistant</b>	VDE 0472 p.803 B//EN 60811.2.1
<b>Flame Resistant</b>	EN 60332-1-1 // EN 60332-1-3 // FT1// UL 1581 sce.1061//EN 50265.2.1
<b>UL/CSA LISTED, DESINA</b>	Yes
<b>Jacket Colour</b>	Thermoplastic compound - Orange - RAL2003
<b>Resistivity of Cable at 20°C [Ohm/km]</b>	- 1.5 mm <sup>2</sup> = 13.3, 4 mm <sup>2</sup> = 4.95
<b>Max Useful Length</b>	75 m



### Sensor Cable

Cable Code	Cable Composition	External Diameter (mm)
SC007SH00	(3x (2x 0.14 mm <sup>2</sup> ) + 4x 0.14 mm <sup>2</sup> + 2x 0.50 mm <sup>2</sup> )	9 ± 0.4mm

Operating Temperature	-20°C ... to + 60°C
Storage Temperature	-50°C ... to + 60°C
Nominal Voltage	UL AWM – CSA AWM U = 30 V
Bending Radius (Dynamic)	≥ 10.5 x external diameter
Bending Radius (Static)	≥ 7 x internal diameter
Maximum Speed	220 m/min
Maximum Acceleration	10 m/sec <sup>2</sup>
Cycles	10.000.000
Torsion max	+/- 30°/m
Pulling Force (Dynamic)	≤ 50 N/mm <sup>2</sup>
Pulling Force (Static)	≤ 120 N/mm <sup>2</sup>
Oil Resistant	VDE 0282 p.10 HD 22.10 S1
Flame Resistant	EN 60332-1 - EN 50265-2-1
UL/CSA LISTED, DESINA	Yes
Jacket Colour	Green - RAL6018
Resistivity of Cable at 20°C [Ohm/km]	0.14mm <sup>2</sup> ≤ 149 Ohm/km 0.50mm <sup>2</sup> ≤ 41 Ohm/km
Max Useful Length	75 m

### Fan Cable for BHL and AMS Motors

Cable Code	Cable Composition	External Diameter (mm)
NC010NL00	([3+T] x1,5 mm <sup>2</sup> (not shielded))	8 ± 0.2



### Raw Cable Ordering Codes

#### Raw Power Cable Ordering Code <sup>1</sup>

	<b>PC</b>	<b>015</b>	<b>B</b>	<b>H</b>	<b>0</b>	<b>0</b>
<b>Cable Type</b>						
• Power Cable						
<b>Cable Section</b>						
• Cable Section 1.5 mm <sup>2</sup>		015				
• Cable Section 4 mm <sup>2</sup>		040				
• Cable Section 6 mm <sup>2</sup>		060				
• Cable Section 10 mm <sup>2</sup>		100				
• Cable Section 21.5 mm <sup>2</sup>		215				
<b>Brake</b>						
• With Brake			B			
• Without Brake			N			
<b>Application</b>						
• High Performance				H		
• Basic Performance				L		
<b>Cable Alone</b>						
• Fixed Value					0	0

#### Raw Power Cable Ordering Code <sup>1</sup>

	<b>SC</b>	<b>007</b>	<b>S</b>	<b>H</b>	<b>0</b>	<b>0</b>
<b>Cable Type</b>						
• Sensor Cable						
<b>Identification Number</b>		007				
<b>Variant</b>			S			
<b>Application</b>						
• High Performance				H		
<b>Cable Alone</b>						
• Fixed Value					0	0

10

<sup>1</sup> Note: the required length of raw cable (max 75 m) is specified as 'quantity' in the order.



### Raw Cable Ordering Codes

#### Raw Power / Sensor Cable Ordering Code <sup>1</sup>

	PX	015	B	H	0	0
<b>Cable Type</b>						
• Power and signal cable (for SHX, SPX motors)						
<b>Cable section</b>						
• Power cable section 0.75 mm <sup>2</sup>		007				
• Power cable section 1.5 mm <sup>2</sup>		015				
<b>Brake</b>						
• With brake			B			
<b>Application</b>						
• High Performance				H		
<b>Cable Alone</b>						
• Fixed Value					0	0

#### Raw Power Cable Ordering Code <sup>1</sup>

	NC	010	N	L	0	0
<b>Cable Type</b>						
• Others Cable						
<b>Identification Number</b>						
		010				
<b>Variant</b>						
			N			
<b>Application</b>						
• Basic Performance				L		
<b>Cable Alone</b>						
• Fixed Value					0	0

<sup>1</sup> Note: the required length of raw cable (max 20 m for PX007, max 75 m for PX015 and NC010) is specified as 'quantity' in the order.

### Ordering Raw Cable - Example

Cable Code Example	Raw Cable Length Definition
PC015BH00 „Quantity“ 50 m Raw Cable Length Definition	The raw cable length is defined as 'quantity' in the order. In this case the raw power + brake cable length is 50 m.



### Power Assembly Cable Ordering Code

	<b>PC</b>	<b>015</b>	<b>B</b>	<b>H</b>	<b>0</b>	<b>0</b>	<b>M</b>	<b>000</b>	<b>0</b>
<b>Cable Type</b>									
• Power Cable									
<b>Cable Section</b>									
• Cable Section 1.5 mm <sup>2</sup> 015									
• Cable Section 4 mm <sup>2</sup> 040									
• Cable Section 10 mm <sup>2</sup> 100									
<b>Brake</b>									
• With Brake                        B									
• Without Brake                    N									
<b>Application</b>									
• High Performance                H									
• Basic Performance               L									
<b>Motor Connector</b>									
• Without connector                0									
• AMOCON004D                    4									
• AMOCON005D                    5									
<b>Drive Connector</b>									
• Without connector                0									
• AEOCON018                        1									
• AEOCON013                        2									
• AEOCON015                        5									
<b>Cable Assembly</b>									
<b>Cable Length</b>									
• Meter (m)									
<b>Cable Length</b>									
• 0.1 meter (dm)									

10

Note:

- The max cable length is 75 m
- Not all combinations of cable/connector couplings are possible



Power and brake cable



### Sensor Assembly Cable Ordering Code

	SC	007	S	H	0	0	M	000	0
<b>Cable Type</b>									
• Sensor Cable									
<b>Identification number</b>		007							
<b>Variant</b>			S						
<b>Application</b>									
• High Performance				H					
<b>Motor Connector</b>									
• Without connector						0			
• CONN125D00						1			
• AMOCON002D						2			
<b>Drive Connector</b>									
• Without connector							0		
• AEOCON012							4		
<b>Cable Assembly</b>									
<b>Cable Length</b>									
• Meter (m)									
<b>Cable Length</b>									
• 0.1 meter (dm)									

Note:

- The max cable length is 75 m
- Not all combinations of cable/connector couplings are possible



Sensor cable



### Single Motor Cable Assembly (for SHX and SPX Motors) Ordering Code

	PX	007	B	H	6	0	M	000	0
<b>Cable Type</b>									
• Power and signal cable (for SHX, SPX motors)									
<b>Cable Section</b>									
• Power cable section 0.75 mm <sup>2</sup>		007							
• Power cable section 1.5 mm <sup>2</sup>		015							
<b>Brake</b>									
• With brake			B						
<b>Application</b>									
• High Performance				H					
<b>Motor Connector</b>									
• Without connector						0			
• AMOCON006D						6			
<b>Drive Connector</b>									
• Without connector							0		
• AEOCON018 + AEOCON019							6		
• AEOCON013 + AEOCON019							7		
<b>Cable Assembly</b>									
<b>Cable Length</b>									
• Meter (m)									
<b>Cable Length</b>									
• 0.1 meter (dm)									

Note:

- The max cable length is: 20m for PX007 and 75m for PX015
- Not all combinations of cable/connector couplings are possible
- Whenever the drive connector is not required add 50 cm of cable for the encoder connections



Encoder cable (power/sensor)



### Fan Assembly Cable (for AMS, BHL Motors) Ordering Code

	NC	010	N	L	7	0	M	000	0
<b>Cable Type</b> • Fan Cable									
<b>Identification number</b>		010							
<b>Variant</b>			N						
<b>Application</b> • Basic Performance				L					
<b>Motor Connector</b> • CONN113D00					7				
<b>Drive Connector</b> • Without connector						0			
<b>Cable Assembly</b>									
<b>Cable Length</b> • Meter (m)									
<b>Cable Length</b> • 0.1 meter (dm)									



Fan cable





### BHX and BPX Connectors, Cables and Cable Assemblies

BHX / BPX	Connectors		Cable		Cable Assemblies <sup>1</sup>	
	Power	Sensor	Power	Sensor	Power	Sensor
0551V5... <sup>2</sup>	AMOCON004D	AMOCON002D	PC015xy00	SC007SH00	PC015xy4zMnnnn	SC007SH2wMnnnn
0751V5...						
0752V5...						
0951V5...						
0952N5...						
0952V5...						
1261N5...						
1261V5...						
1262N5...						
1262V5...						
1263N5...						
1263R5...						
1552N5...						
1552R5...						
1554N5...						

<sup>1</sup> Note for the cable assemblies:

x: cable with or without brake wires  
 x = B for cable with brake wires  
 x = N for cable without brake wires

y: cable performance  
 y = H for High performance cable  
 y = L for Basic performance cable

z: power connector on drive side  
 z = 0 without connector  
 z = 1 with connector AEOCON018  
 z = 2 with connector AEOCON013

w: sensor connector on drive side  
 w = 0 without connector  
 w = 4 with connector AEOCON012

nxxx = cable length in 0.1 m  
 nxxx = 0105 = 10.5 m

<sup>2</sup> Available as BPX only



### SHX and SPX Connectors, Cables and Cable Assemblies

SHX / SPX	Motor Connector	Cable	Cable Assemblies <sup>1</sup>
0751V5...	AMOCON006D	PX007BH00 or PX015BH00	PX007BH6yMnnnn or PX015BH6zMnnnn
0752V5...			
0951V5...			
0952N5...			
0952V5...			
1261N5...			
1261V5...		PX015BH00	PX015BH6zMnnnn
1262N5...			
1262V5...			
1263R5...		PX007BH00 or PX015BH00	PX007BH6yMnnnn or PX015BH6zMnnnn
1552N5...			
1552R5...			
1554N5...			

<sup>1</sup> Note for the cable assemblies:

y: power connector on drive side  
 y = 0 without connector  
 y = 6 with connector AEOCON018 + AEOCON019

z: power connector on drive side  
 z = 0 without connector  
 z = 6 with connector AEOCON018 + AEOCON019  
 z = 7 with connector AEOCON013 + AEOCON019

nxxx = cable length in 0.1 m  
 nxxx = 0105 = 10.5 m



### BPH Connectors, Cables and Cable Assemblies

BPH	Connectors		Cable		Cable Assemblies <sup>1</sup>					
	Power	Sensor	Power	Sensor	Power	Sensor				
0751N5...	AMOCON004D		PC015xy00		PC015xy4zMnnnn					
0751V5...										
0752N5...										
0752V5...										
0754N5...										
0952N5...										
0952V5...										
0953N5...										
0953V5...										
0955N5...										
1152N5...										
1152V5...										
1153K5...										
1153N5...										
1153V5...										
1154K5...										
1154N5...										
1154V5...			AMOCON002D				PC040xy00	SC007SH00	PC040xy4zMnnnn	SC007SH2wMnnnn
1156N5...							PC015xy00		PC015xy4zMnnnn	
1422K5...										
1422N5...										
1422R5...										
1423K5...	PC040xy00	PC040xy4zMnnnn								
1423N5...				PC015xy00		PC015xy4zMnnnn				
1423R5...	PC040xy00	PC040xy4zMnnnn								
1424K5...										
1424N5...										
1424R5...										
1427N5...	AMOCON005D		PC100xy00		PC100xy5zMnnnn					
1902K5...										
1902N5...										
1902R5...										
1903K5...										
1903N5...										
1904K5...										
1904N5...										
1905H5...										
1905L5...							AMOCON005D		PC100xy00	
1907K5...										
1907N5...										
190AK5...										

<sup>1</sup> See next page for cable assembly notes



### BPG Connectors, Cables and Cable Assemblies

BPG	Connectors		Cable		Cable Assemblies 1			
	Power	Sensor	Power	Sensor	Power	Sensor		
0751N5...	AMOCON004D	AMOCON002D	PC015Ny00	SC007SH00	PC015Ny4zMnnnn	SC007SH2wMnnnn		
0752N5...								
0952N5...								
0953N5...								
1152N5...								
1153K5...								
1153N5...								
1153V5...								
1422N5...								
1423N5...								
1424K5...								
1424R5...								
1427N5...								
1902K5...							PC040Ny00	PC040Ny4zMnnnn
1902N5...								
1903K5...								
1903N5...	AMOCON005D	PC100Ny00	PC100Ny5zMnnnn					
1904N5...								
1905L5...								

<sup>1</sup> Note for the cable assemblies:

x: cable with or without brake wires  
 x = B for cable with brake wires  
 x = N for cable without brake wires

y: cable performance  
 y = H for High performance cable  
 y = L for Basic performance cable

z: power connector on drive side  
 z = 0 without connector  
 z = 1 with connector AEOCON018  
 z = 2 with connector AEOCON013  
 z = 5 with connector AEOCON015

w: sensor connector on drive side  
 w = 0 without connector  
 w = 4 with connector AEOCON012

n n n n = cable length in 0.1 m  
 n n n n = 0105 = 10.5 m



### BHL Connectors, Cables and Cable Assemblies

BHL	Connectors			Cables		
	Power	Sensor	Fan	Power	Sensor	Fan
2601N5...	AMOCON005D	AMOCON002D	CONN113D00	PC100xH00	SC007SH00	NC010NL00
2601N1...	None			PC215BH00		
2602K5...	AMOCON005D			PC100xH00		
2602K1...	None			PC215BH00		

BHL	Cable Assemblies <sup>1</sup>			High-Strength Cable Gland
	Power	Sensor	Fan	
2601N5...	PC100xH50Mnnnn	SC007SH2wMnnnn	NC010NL70Mnnnn	None
2601N1...	PC215BH00			BMHQPRE3
2602K5...	PC100xH50Mnnnn			None
2602K1...	PC215BH00			BMHQPRE3

<sup>1</sup> Note for the cable assemblies:

x: cable with or without brake wires  
 x = B for cable with brake wires  
 x = N for cable without brake wires

w : sensor connector on drive side  
 w = 0 without connector  
 w = 4 with connector AEOCON012

nnnn = cable length in 0.1 m  
 nnnn = 0105 = 10.5 m



### AMS and IM18 Connectors, Cables and Cable Assemblies

AMS	Connectors		High-Strength Cable Gland	Cable			Cable Assemblies <sup>1</sup>	
	Sensor	Fan		Power	Sensor	Fan	Sensor	Fan <sup>2</sup>
100SB1...	CONN125D00	CONN113D00	BMHQPRE2	PC060BH00	SC007SH00	NC010NL00	SC007S-H1wMnnnn	NC010N-L70Mnnnn
100MB1...								
100GB1...								
100SD1...								
100MD1...								
100GD1...								
132SA1...								
132SC1...								
132SE1...								
132MA1...								
132MC1...								
132ME1...								
132LA1...								
132LE1...								
132SF1...								
132SG1...								
132SH1...								
132MF1...								
132MG1...								
132MH1...								
132LF1...								
132LI1...								
132LH1...								
160MA1...								
160MB1...								
160MC1...								
160LA1...								
160LB1...								
160LC1...								

IM	Connectors		High-Strength Cable Gland	Cable			Cable Assemblies <sup>1</sup>	
	Sensor	Fan		Power	Sensor	Fan	Sensor	Fan <sup>2</sup>
18MK14...	AMO-CON002D	CONN114D00	2 x M50	2 x (4x25 mm <sup>2</sup> )	SC007SH00	2x1 mm <sup>2</sup>	SC007S-H2wMnnnn	-

<sup>1</sup> Note for the cable assemblies:  
w: sensor connector on drive side  
w = 0 without connector  
w = 4 with connector AEOCON012  
nnnn = cable length in 0.1 m  
nnnn = 0105 = 10.5 m

<sup>2</sup> Only the motor connector is present and assembled



### Motor Connectors Description

Accessories	Order Code	Description	
Motor Sensor Connector	AMOCON002D	17 pole connector	
Motor Power Connector	AMOCON004D	6 pole connector	
Motor Power Connector	AMOCON005D	6 pole connector	
Motor Power / Encoder Connector	AMOCON006D	9 pole connector	
Motor Fan Connector	CONN113D00	5 pole connector	
Motor Fan Connector	CONN114D00	2 pole connector	
Motor Sensor Connector	CONN125D00	23 pole connector	
Power Cable Gland	BMHQPRE2	High-Strength Cable gland Pg 21	
Power Cable Gland	BMHQPRE3	High-Strength Cable gland Pg 29	





### FlexiumPro 6 and FlexiumPro 8 System

FlexiumPro 6 and FlexiumPro 8 are the right choice for controlling machines with relatively few axes and spindles, but with a high demand for speed and precision.

FlexiumPro 6 is designed for milling and turning machines, as well as for water jet and laser cutting machines.

FlexiumPro 8 offers additional features for cylindrical and flat grinding, and for gear cutting. It can also be adapted to the requirements of special machines.

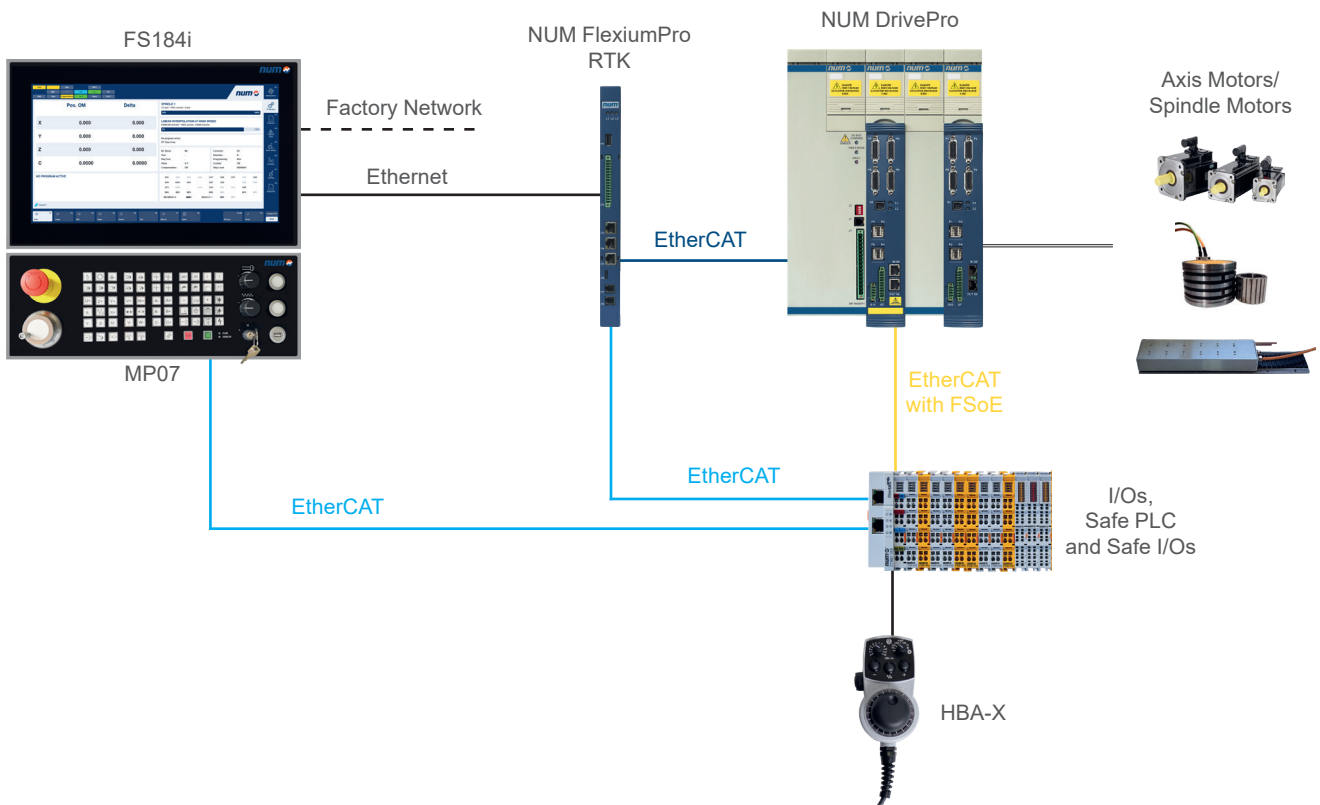

#### Maximum Configuration

- FlexiumPro 6: 4 Axes + 1 Spindle  
1 Channel
- FlexiumPro 8: 5 Axes or  
4 Axes + 1 Spindle  
2 Channels

### FlexiumPro with Multi-Panel

For operation of large machines, several HMIs are often connected modularly; a requirement FlexiumPro easily meets.

Example with FS184i and MP07:

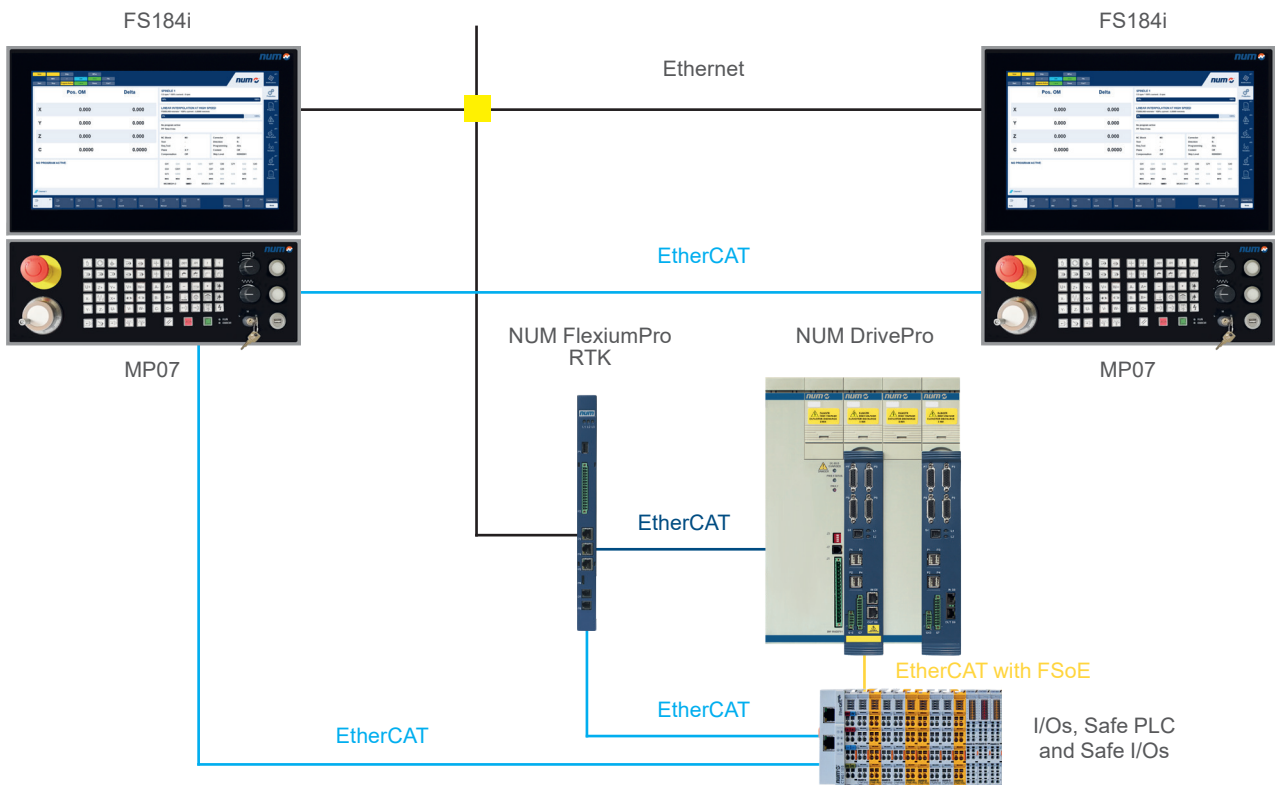

### FlexiumPro with Office PC

Custom applications such as CAD/CAM programs usually work best with a high performance PC and therefore it is not unusual for this computer to be replaced with a faster version a number of times during the lifespan of a machine. FlexiumPro supports this configuration as well.

This objective also applies to NUMROTOplus®.

Example with FS244 and MP07:

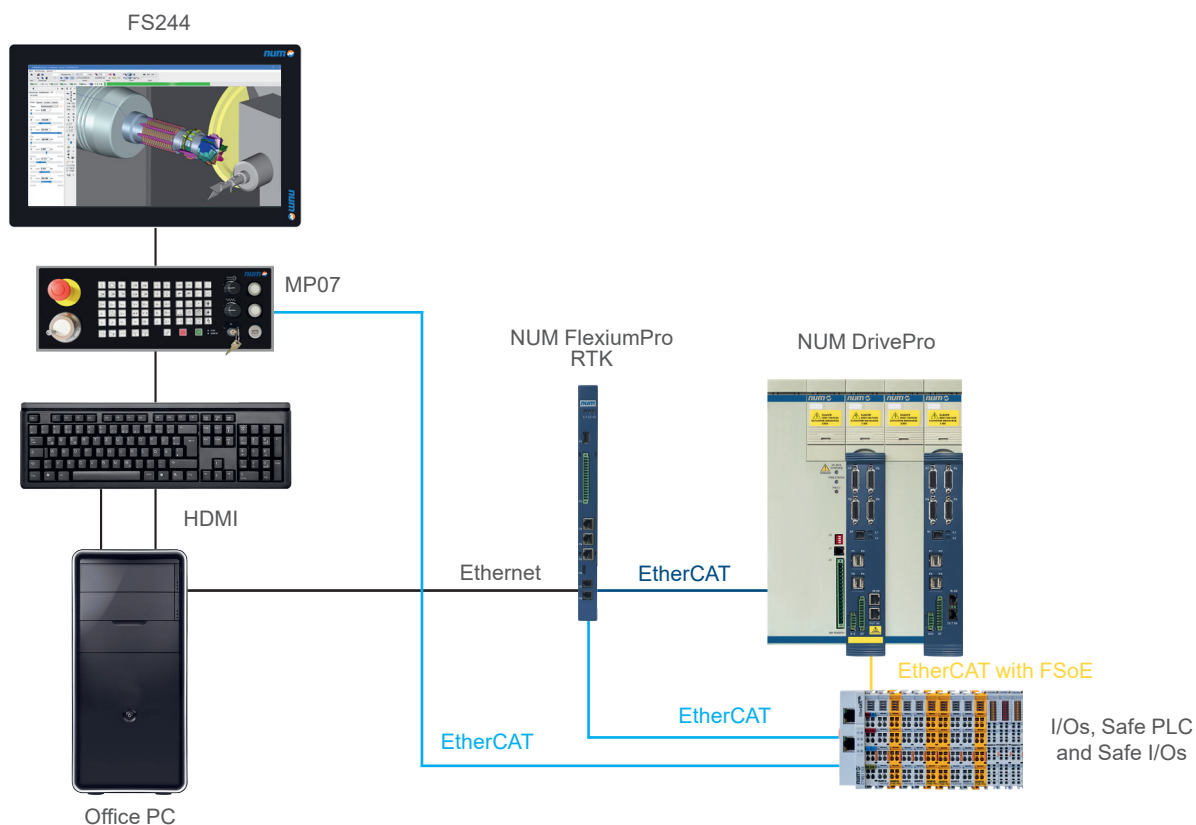

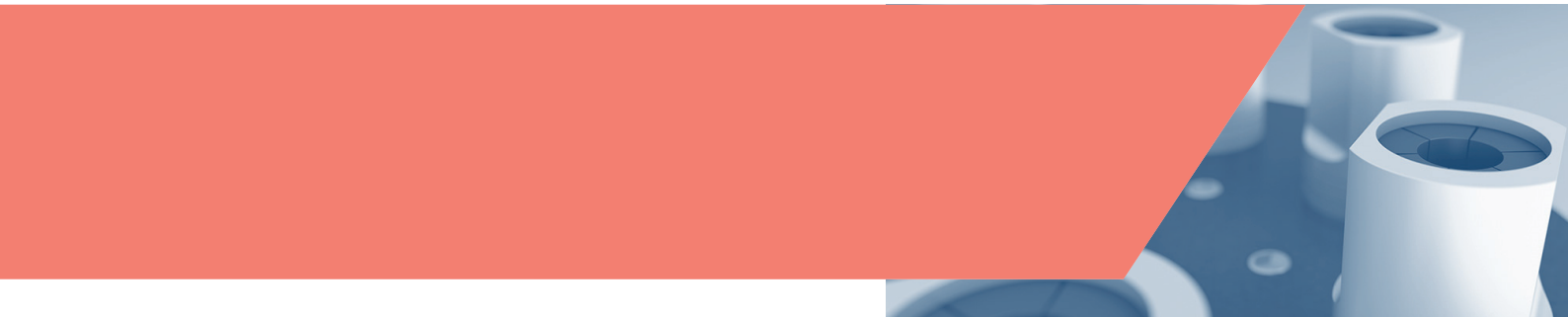

# General Information

## Addresses / Contacts of all NUM Subsidiaries

### NUM Worldwide

#### Headquarters NUM Worldwide

Country	Address	Telephone	Fax, Email
<b>Switzerland</b>	NUM AG Battenhusstrasse 16 9053 Teufen	+41 71 335 04 11	+41 71 333 35 87 sales.ch@num.com service.ch@num.com

#### Subsidiaries, Distribution and Service Europe

Country	Address	Telephone	Fax, Email
<b>Austria</b>	NUM Verkaufsbüro Österreich Pummerinplatz 1 4490 St. Florian	+43 72 24 80 116	+41 713 33 35 87 sales.ch@num.com service.ch@num.com
<b>Finland</b>	NUCOS OY Keiserinviitta 16 33960 Pirkkala Tampere	+358 3 342 7100	+358 3 342 7130 oiva.viitanen@nucos.fi
<b>France</b>	NUM S.A.S. Immeuble le Naxos 56, rue des Hautes Pâtures 92737 Nanterre Cedex	Hotline: +33 156 47 58 06 Sales: +33 156 47 58 58	sales.fr@num.com service.fr@num.com
<b>Germany</b>	NUM GmbH Zeller Straße 18 73271 Holzmaden	+49 7023 74400	+49 7023 744010 sales.de@num.com service.de@num.com
<b>Germany North</b>	NUM GmbH Niederlassung Nord Grüner Talstraße 65 58644 Iserlohn	+49 7023 7440 22	+49 2374 9368466 sales.de@num.com service.de@num.com
<b>Germany East</b>	NUM GmbH Büro Ost 93142 Maxhütte-Haidhof	+49 7023 7440 21	sales.de@num.com service.de@num.com
<b>Italy</b>	NUM SpA Sede Legale Via F Somma 62 20012 Cuggiono (MI)	+39 02 97 969 350	+39 02 97 969 351 sales.it@num.com service.it@num.com
<b>Spain</b>	NUM CNC HighEnd Applications S. A. Errementari Plaza 8 Post Box 55 20560 Oñati	+34 943 78 02 65	sales.es@num.com service.es@num.com

Please see [www.num.com](http://www.num.com) for further contacts and most recent contact details

# General Information

## Addresses / Contacts of all NUM Subsidiaries

### NUM Worldwide

#### Subsidiaries, Distribution and Service Europe

Country	Address	Telephone	Fax, Email
Sweden	ConRoCo AB Formvägen 1 777 93 Söderbärke	+46 240 65 01 16	+46 240 65 01 21 info@conroco.com
Switzerland	NUM SA Erlenstrasse 32 2555 Brügg	+41 32 346 50 50	+41 32 346 50 59 sales.ch@num.com service.ch@num.com
United Kingdom	NUM (UK) Ltd. Unit 3 Fairfield Court Seven Stars Industrial Estate Wheler Road Coventry, CV3 4LJ	+44 2476 301 259	+44 2476 305 837 sales.uk@num.com service.uk@num.com
Turkey	NUM Servis Türkiye Feyzullah Cad. Beyazköşk Apt. 17 / 12 34840 Maltepe-Istanbul	+90 216 371 40 20	+90 538 425 66 11 numserviceturkiye@yahoo.com.tr

#### Africa

Country	Address	Telephone	Fax, Email
Algeria (Maghreb)	NUM S.A.S. Immeuble le Naxos 56, rue des Hautes Pâtures 92737 Nanterre Cedex	Hotline: +33 156 47 58 06 Sales: +33 156 47 58 58	+33 1 56 47 58 90 sales.fr@num.com service.fr@num.com
South Africa	MACHINE TOOL PROMOTIONS (Pty) Fraser Street 12 Vanderbijlpark 1911	+27 16 9311564	+27 16 9338979 abraham@mtpsa.co.za

#### America

Country	Address	Telephone	Fax, Email
USA	NUM Corporation 603 East Diehl Road, Suite 115 Naperville, IL 60563	+1 630 505 77 22	+1 630 505 77 54 sales.us@num.com service.us@num.com
Brazil	LOSUNG Technical Assistance and Comerce Ltda. Av. Anápolis, 500 06404-250 Bethaville-BARUERI-SP	+55 11 419 13 714	+55 11 419 58 210 contato@losung.com.br
Mexico (Central America)	VISI Series México, S.A. de C.V. Sierra de Ahuacatlan, No. 136 Villas del Sol Santiago de Querétaro, Qro. CP 76046	+1 442 248 2125	+1 442 223 6803 service.mx@num.com

Please see [www.num.com](http://www.num.com) for further contacts and most recent contact details

### NUM Worldwide

#### Subsidiaries, Distribution and Service Asia/Australia

Country	Address	Telephone	Fax, Email
China	NUM Numerical Control Technology (Shanghai) Co., LTD No. 604, Building A, Chamtime Plaza, No. 2889, Jinke Road, Pudong New District, Shanghai 201203	+86 21 6882 0958	+86 21 6882 0959 sales.cn@num.com service.cn@num.com
	NUM Numerical Control Technology (Shanghai) Co., Ltd Guangzhou Branch Rm. 1005, Building C3, Grand Tech Park, No. 28, Kaitai Avenue, Huangpu District, Guangzhou	+86 20 2232 5686	sales.cn@num.com service.cn@num.com
Taiwan	NUM Taiwan Ltd. 7F-2 No. 536, Sec. 2 Taiwan Boulevard Taichung City 40353	+886 4 2316 9600	+886 4 2316 9700 sales.tw@num.com service.tw@num.com
Thailand	Gsixty Co. Ltd. 508/51 Sukhontasawat Road Ladphrao, Bangkok 10230	+66 2 578 34 54 +66 896 51 59 50	+66 2 578 34 54 jameschaput@hotmail.com
Australia	Australian Industrial Machine Services Pty. Ltd. 28 Westside Drive Laverton North Victoria 3026	+61 3 9314 3321	+61 3 9314 3329 enquiries@aimservices.com.au
	JD Motion Pty Ltd U26, 62 Turner Road Smeaton Grange New South Wales 2567	+61 246 470 864	admin@jdmotion.au
India	NUMIndia Automation Private Limited N9, 2 <sup>nd</sup> Floor, 24 <sup>th</sup> Main JP Nagar 1st Phase, Bangalore 560078 (IN)	+91 99451 56423	sales.in@num.com service.in@num.com

Please see [www.num.com](http://www.num.com) for further contacts and most recent contact details

### Declaration of Conformity

---

The product described in this catalog, used in conformity with the relevant manuals, fulfills the basic requirements of Electromagnetic Compatibility and of Electrical Safety as prescribed by the Directives :

2014/35/EU "Low voltage (LVD)" dated 29/3/2014

2014/30/EU "Electromagnetic compatibility (EMC)" dated 29/3/2014

The products of this catalog are intended to be incorporated into machinery or assembled with other machinery to constitute products covered by the council directive. Commissioning is forbidden until the products have been integrated in a machine that conforms with the Directive 2006/42/EC.

### Export terms for NUM products

---

1. Because of their technical characteristics or in some case their utilization, certain of NUM's products may be required to comply with the requirements of Swiss or European regulations and/or US regulations concerning control of the final destination.

Relevant information is given on our purchase order acknowledgments, invoices and delivery notes.

These provisions apply to NUM's products so identified on our purchase order acknowledgments, invoices and delivery notes.

2. Accordingly, the purchaser undertakes to fully comply in all respects with the regulations of his country and, as the case may be, with Swiss, European and / or US regulations relating to the control of final destination of dual use products.

The purchaser undertakes to introduce and to follow its own business control procedures in order to ensure that, in respect of the resale of Dual Use Products, such national legal obligations will be implemented.

3. In any case, the purchase orders received by NUM shall be accepted subject to NUM obtaining any required authorizations.

### Imprint

---

© Copyright NUM AG

Publication date: January 2025

Editor and layout: Jacqueline Böni and Larissa Kühne

Publisher: NUM AG, Battenhusstrasse 16, 9053 Teufen, Switzerland  
sales.ch@num.com, www.num.com

All rights reserved. No part of this document may be copied or reproduced in any form or by any means whatsoever, including photographic or magnetic processes. The transcription on an electronic machine of all or part of the contents is forbidden.

Subject to technical changes, errors and misprints excepted.

The software mentioned herein is the property of NUM AG. Each copy of the software confers on the holder a non-exclusive license strictly limited to use of the said copy. No copy or other forms of duplication of this product is authorized, with the exception of backup copies of the software.

The physical, technical and functional characteristics of the hardware and software products and the services described in this document are subject to modification and cannot under any circumstances be construed as contractually binding.

Windows is a registered trademark of Microsoft Corporation.

EtherCAT is a registered trademark of Beckhoff Automation.





# Complete CNC Solutions Worldwide



## NUM systems and solutions are used worldwide.

Our global network of sales and service locations guarantees professional service from the beginning of a project to its execution and for the complete life cycle of the machine.

NUM has service centers around the world. Visit our website for the current list of locations.

[www.num.com](http://www.num.com)



Follow us on our social media channels for the latest information on NUM CNC Applications.

- [linkedin.com/company/num-ag](https://www.linkedin.com/company/num-ag)
- WeChat-ID: NUM\_CNC\_CN
- [twitter.com/NUM\\_CNC](https://twitter.com/NUM_CNC)
- [facebook.com/NUM.CNC.Applications](https://facebook.com/NUM.CNC.Applications)